

# CECO Dean

BULLETIN C-3.1.10

**DEAN PUMP®**

**M300 MAGNETIC DRIVE  
SEALLESS PROCESS PUMPS**

ANSI DIMENSIONS AND PERFORMANCE

---

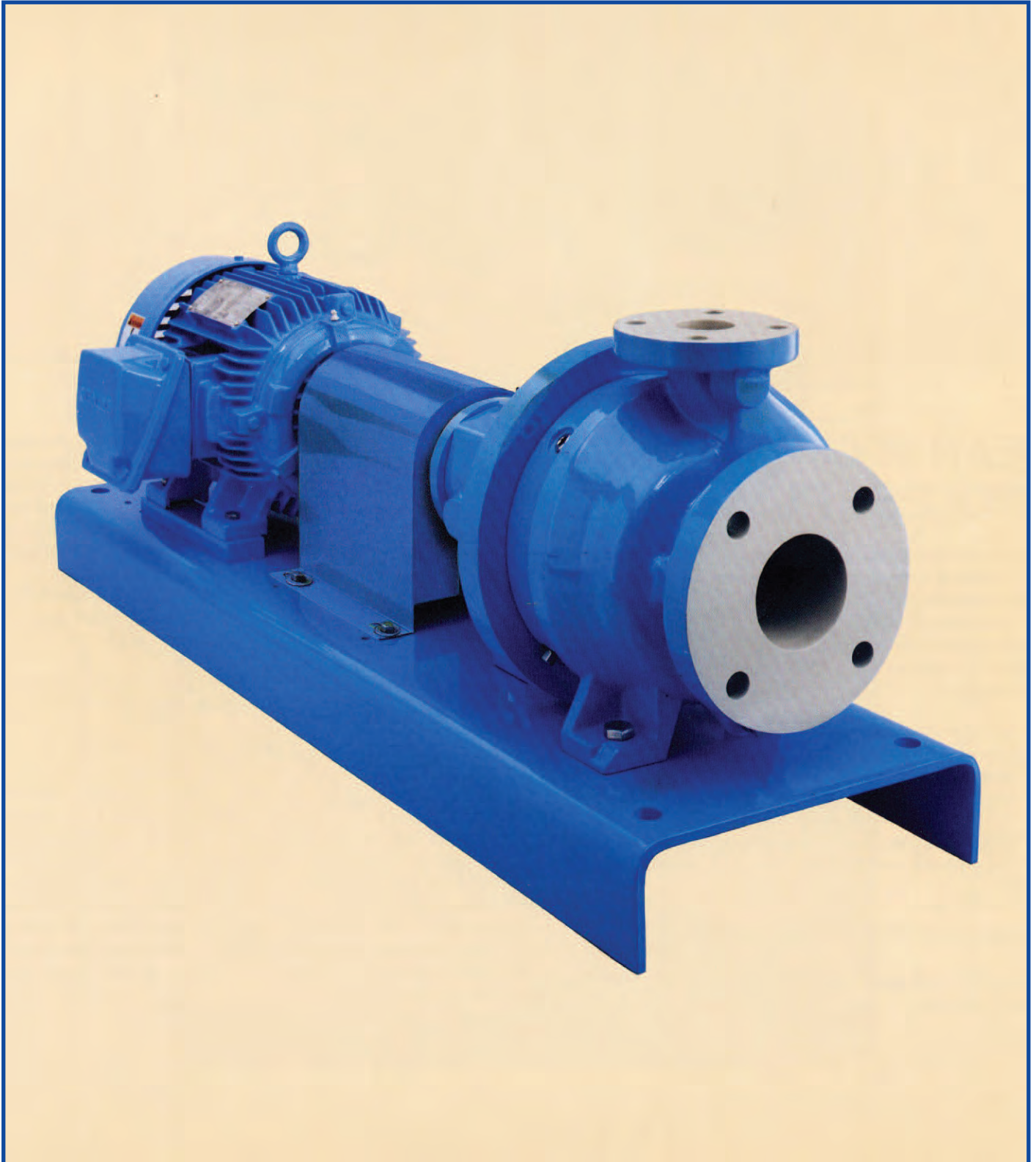

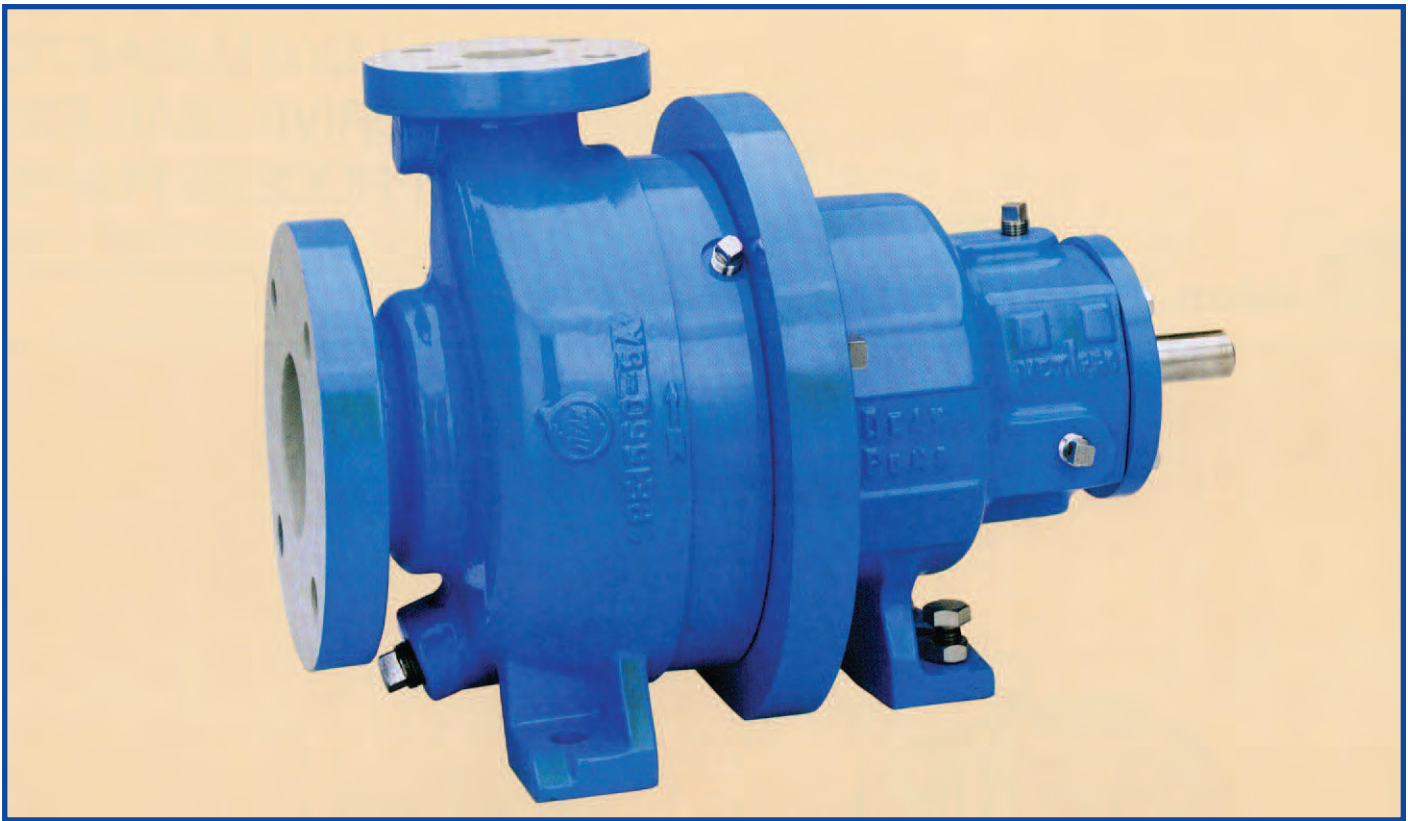

## DEAN PUMP® M300 PROCESS PUMPS

Dean Pump has focused its more than 20 years experience with ANSI chemical process pumps to develop the M300 Magnetic Drive Process Pump. The M300 is designed to efficiently meet your needs for a sealless pump to handle hazardous toxic fluids. A synchronous drive system with permanent rare earth magnets is utilized to eliminate mechanical seals and virtually end pump shaft leakage.

The M300 meets all hydraulic performance and dimensional requirements of ANSI B73.1. They are completely interchangeable with existing ANSI pumps of the same size designation and therefore allow the use of existing piping, baseplates and couplings.

The M300 is available in a wide range of metallurgies. They provide excellent corrosion resistance for your most demanding process services.

### HYDRAULIC COVERAGE/DESIGN

Extensive hydraulic coverage with 12 sizes makes the most efficient selection possible.

The fully enclosed impellers are designed for stable performance and optimum efficiency while maintaining good NPSH characteristics. The liquid flow path through the containment shell is directed back to discharge by an auxiliary impeller on the internal rotor. There is no increase in temperature at the suction eye of the impeller and no effect on the NPSH characteristics of the pump.

Incorporating samarium cobalt rare earth magnets, silicon carbide sleeve bearings, and back pull out design, the M300 gives you reliable performance with low maintenance costs.

The M300 covers a wide performance range with capacities to 1400 GPM, heads to 450 feet, and temperatures to 450°F.

### TODAY'S REQUIREMENTS

EPA regulations regarding fugitive emissions call for a reduction in pump shaft leakage. The M300 is designed to meet the stringent requirements for sealless pumps as demanded by the process industry. Standard features of the pump include 150 lb. flat face flanges, ductile iron power frame, and Hastelloy C containment shell. Optional features include containment shell monitoring and auxiliary containment shell flushing from an external source. With ever increasing concern over our environment, the M300 is the logical solution to your ANSI pump requirements.



# M300 ANSI DIMENSIONS

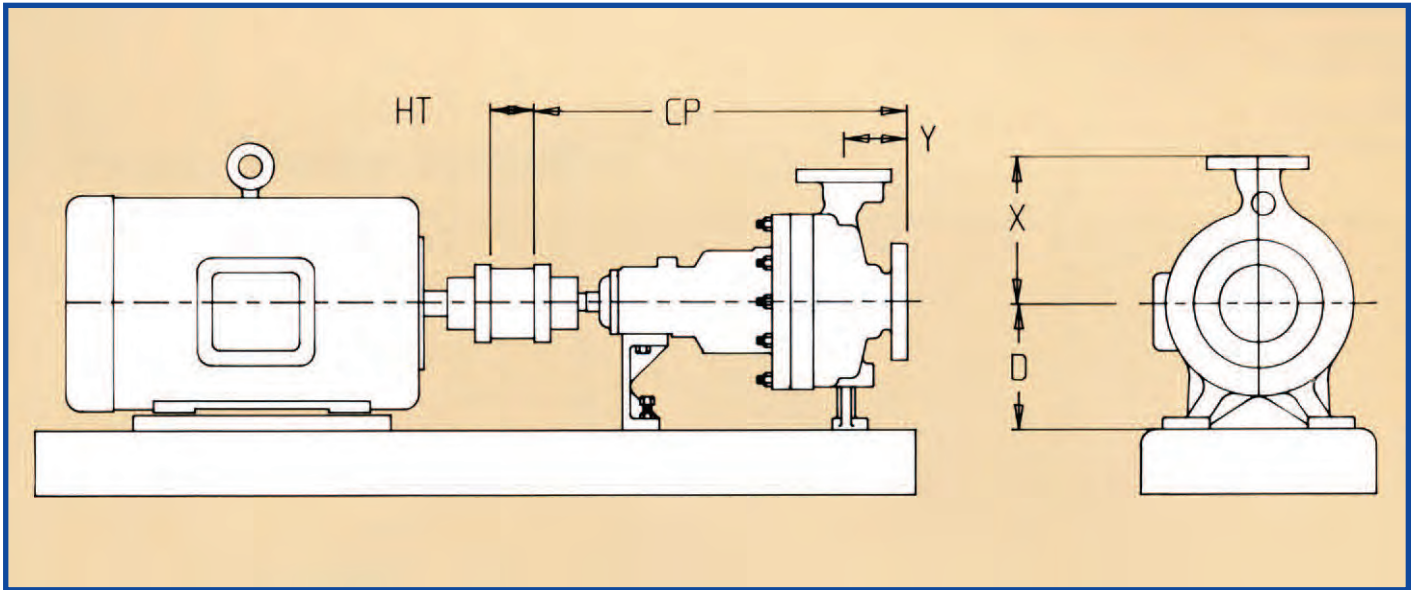

PUMP SIZE	ANSI SIZE	DISCHARGE SIZE	SUCTION SIZE	CP	D	X	Y	HT (MIN.)
1 x 1.5 x 6	AA	1	1.5	17.50 (445)	5.25 (133)	6.50 (165)	4 (102)	3.50 (89)
1 x 1.5 x 8	AA	1	1.5	17.50 (445)	5.25 (133)	6.50 (165)	4 (102)	3.50 (89)
1.5 x 3 x 6	AB	1.5	3	17.50 (445)	5.25 (133)	6.50 (165)	4 (102)	3.50 (89)
2 x 3 x 6	A10	2	3	23.50 (597)	8.25 (210)	8.25 (210)	4 (102)	3.50 (89)
1.5 x 3 x 8.5	A50	1.5	3	23.50 (597)	8.25 (210)	8.50 (216)	4 (102)	3.50 (89)
2 x 3 x 8.5	A60	2	3	23.50 (597)	8.25 (210)	9.50 (242)	4 (102)	3.50 (89)
3 x 4 x 8.5	A70	3	4	23.50 (597)	8.25 (210)	11 (280)	4 (102)	3.50 (89)
1 x 2 x 10	A05	1	2	23.50 (597)	8.25 (210)	8.50 (216)	4 (102)	3.50 (89)
1.5 x 3 x 10	A50	1.5	3	23.50 (597)	8.25 (210)	8.50 (216)	4 (102)	3.50 (89)
2 x 3 x 10	A60	2	3	23.50 (597)	8.25 (210)	9.50 (242)	4 (102)	3.50 (89)
3 x 4 x 10	A70	3	4	23.50 (597)	8.25 (210)	11 (280)	4 (102)	3.50 (89)
4 x 6 x 10	A80	4	6	23.50 (597)	10 (254)	13.50 (343)	4 (102)	3.50 (89)

Dimensions are in inches and (millimeters). Dimensions are approximate and not to be used for construction purposes.



# APPLICATION DATA

The application data necessary to correctly size an M300 pump is more thorough than that needed to size a standard centrifugal pump. The data listed below is the minimum required to assure a satisfactory pump application.

- Fluid
- Service
- Capacity (GPM)
- Specific Gravity at P.T.
- Viscosity at P.T.
- Viscosity at Minimum Temperature
- Pumping Temperature (°F) at Conditioning Point
- Temperature (°F) Minimum/Maximum
- Specific Heat
- Vapor Pressure at P.T.
- Suction Pressure
- Discharge Pressure (PSIG)
- Differential Pressure (PSIG)
- Differential Head (Ft)
- NPSH Available (Ft)

# TYPICAL CONSTRUCTION DETAILS

1. The casing is either ductile iron, 316 SS, or Alloy 20 material and is equipped with 150 lb. flat faced flanges for inlet and outlet connections. The casing is end suction with self venting, top centerline discharge and back pull out design to allow disassembly without disturbing the suction and discharge piping or motor.
2. The impeller is of the enclosed type, single plane dynamically balanced, keyed to the pump shaft and securely held in place with an impeller nut.
3. The backhead is of the same material as the pump casing and serves as a common retainer for the stationary sleeve bearings to ensure concentricity and positive alignment.
4. The internal sleeve bearings (rotating and stationary) are sintered alpha silicon carbide to provide superior abrasion and corrosion resistance. The stationary sleeve bearings are securely held by anti-rotation pins while the rotating journal is keyed to the pump shaft. Each bearing journal is mounted on two Hastelloy-C tolerance rings to insure positive alignment and minimize thermal stress.
5. The containment shell is made of Hastelloy-C and is of one piece construction with no welds. The nominal shell thickness is .050" and is designed in accordance with the table of allowable stress levels for the selected material and the calculations (formulation) for the minimum required thickness as outlined in Section VIII of the ASME Boiler and Pressure Vessel Code. The shell is hydrostatically tested to 1½ times the pump maximum working pressure.
6. The inner magnet assembly is dynamically balanced and keyed to the drive shaft. The magnets are sealed in a corrosion resistant shell to protect the magnets from the liquid pumped. As a minimum, the rotor base and magnet shell are 316 S/S.

7. The outer magnet assembly is dynamically balanced as standard and keyed to the drive shaft. The clearance between the frame housing and the outer rotor is less than the clearance between the outer rotor and the containment shell. This clearance is over the entire length of the outer rotor to provide maximum protection to the containment shell. The outer magnet assembly is mounted on a shaft with a tapered end to ensure positive centering of the outer magnet assembly on the drive shaft.
8. The circulation flow path to the internal sleeve bearings is a dual path to provide maximum lubrication. The circulation path by the inner magnets is from the discharge through the shaft to the auxiliary impeller to the discharge. This circulation flow path will maintain pressure in the shell at or above discharge pressure. The flow by the magnets is not returned to the suction as this may affect the NPSH requirements of the pump.
9. Three power frames are available to allow maximum sizing flexibility from 2 hp to 100 hp at 3600 rpm. The magnets are samarium cobalt as standard to provide maximum strength under elevated temperatures.
10. An instrumentation connection is provided as standard to allow mounting of an RTD to monitor the temperature of the containment shell and liquid in the magnet area of the pump.

# MECHANICAL DESIGN SPECIFICATIONS

	FRAME 1	FRAME 2	FRAME 3
H.P. Rating-Max	Rows of Magnets		Rows of Magnets
@ 3500 RPM	1 2 3 4	1 2 3 4 5 6	1 2 3 4 5
@ 1750 RPM	5 10 15 25	5 10 15 25 30 40	15 30 50 75 100
	2 5 7.5 10	2 5 7.5 10 15 20	7.5 15 25 40 50
Corrosion Allowance: Casing	0.125"		
Impeller Allowance: Standard	Single Plane Dynamic Balance		
Magnet Assembly Balance: Standard	Double Plane Dynamic Balance		
Flanges ANSI Rating Facing: Standard	150#		
Optional Finish	F.F. R.F. 125 rms		
Outer Bearings (Ball) Radial Thrust	6210-2RS 6305NR-2RS	6012-2RS 6307NR-2RS	
Internal Bearings	Silicon Carbide vs. Silicon Carbide		
Shell Corrosion Allowance	Hastelloy C .010"		
Magnets	Samarium Cobalt		
Hydrostatic Test Pressure	430 psig		
Max. Operating Temp.	450°F		
Max. Working Pressure @ 100°F	285 psig		



# M300 HYDRAULIC COVERAGE

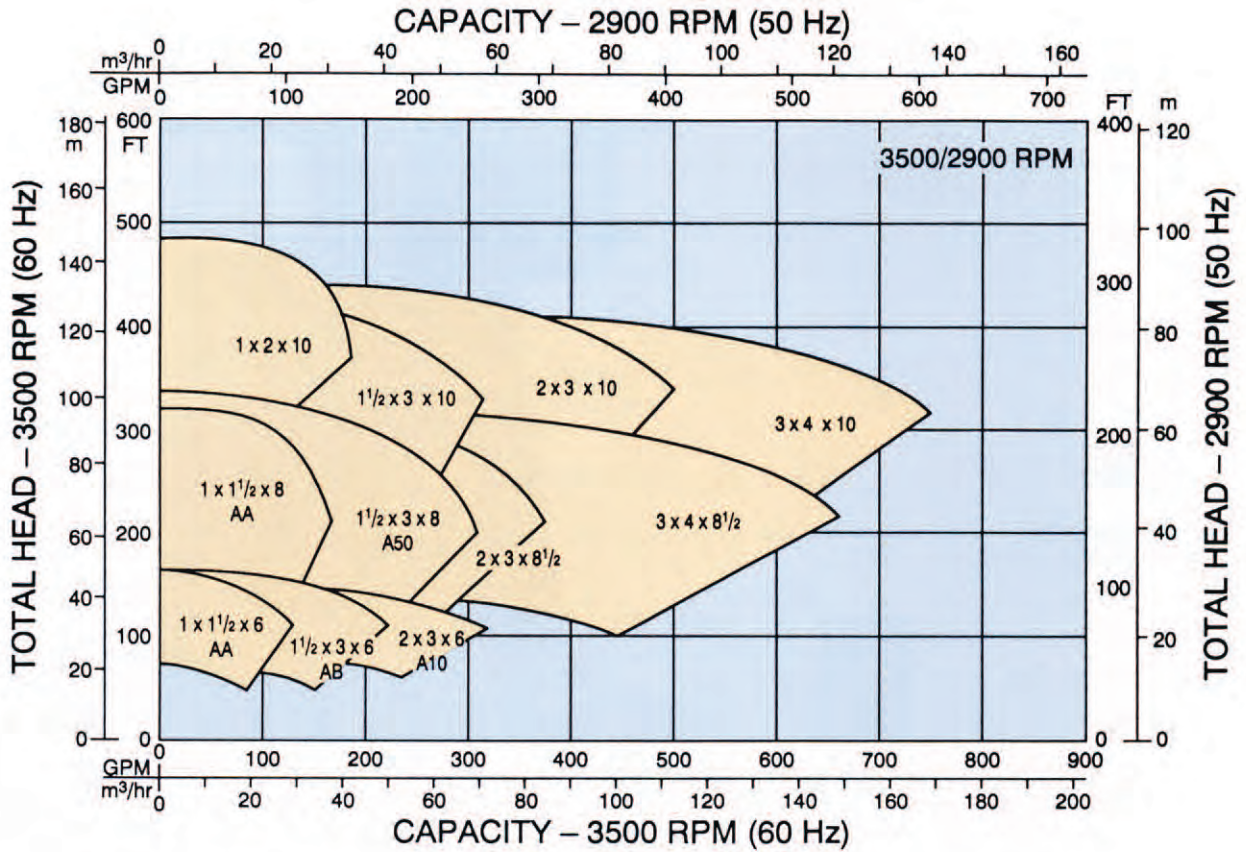

NOTE: Scale is logarithmic.

# THE DEAN PUMP® M300

Hydraulically Balanced  
Enclosed Impeller  
Keyed to Shaft

ANSI Dimensions

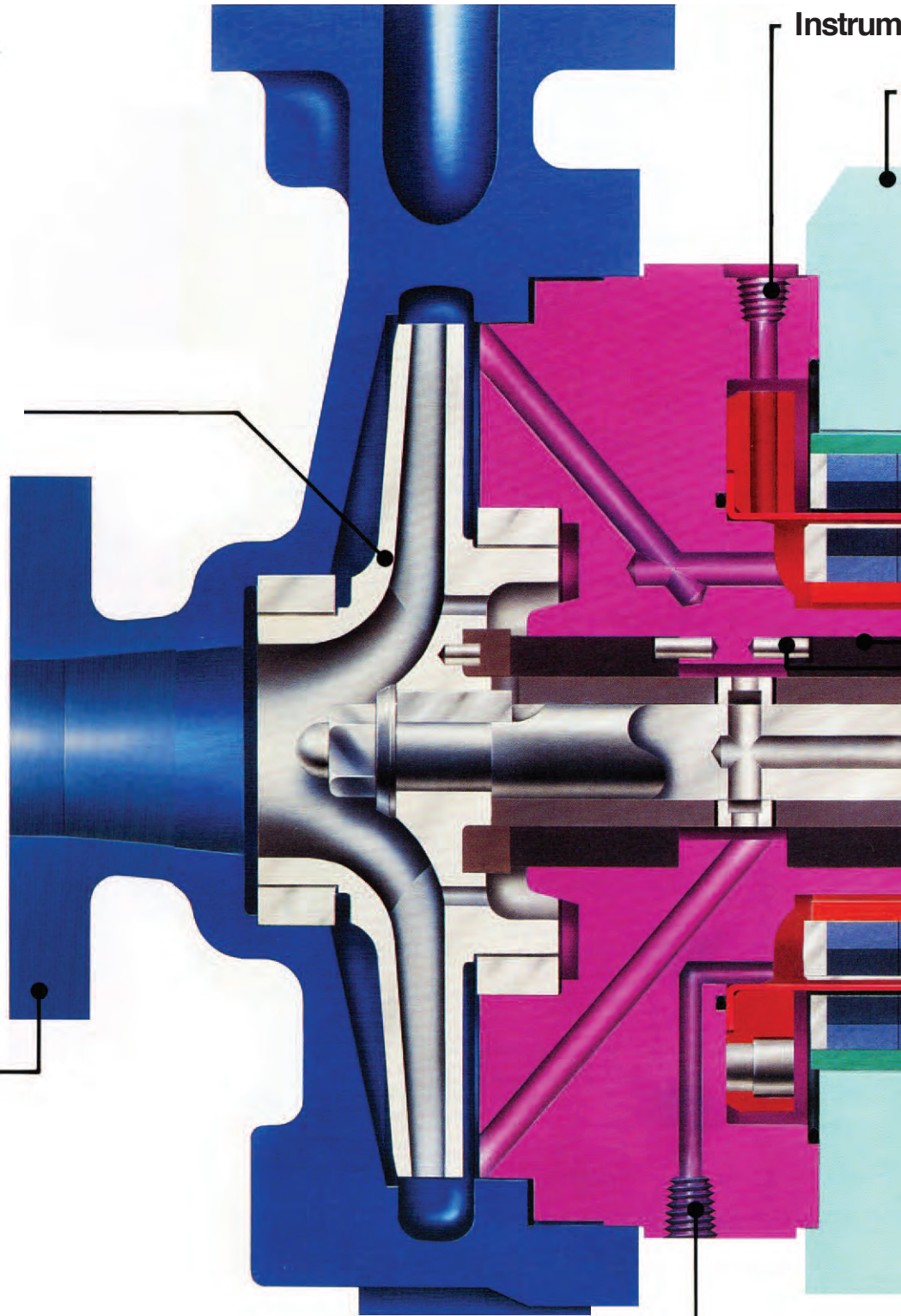

Containment Shell Drain



entation Connection

Heavy Duty Ductile  
Iron Power Frame

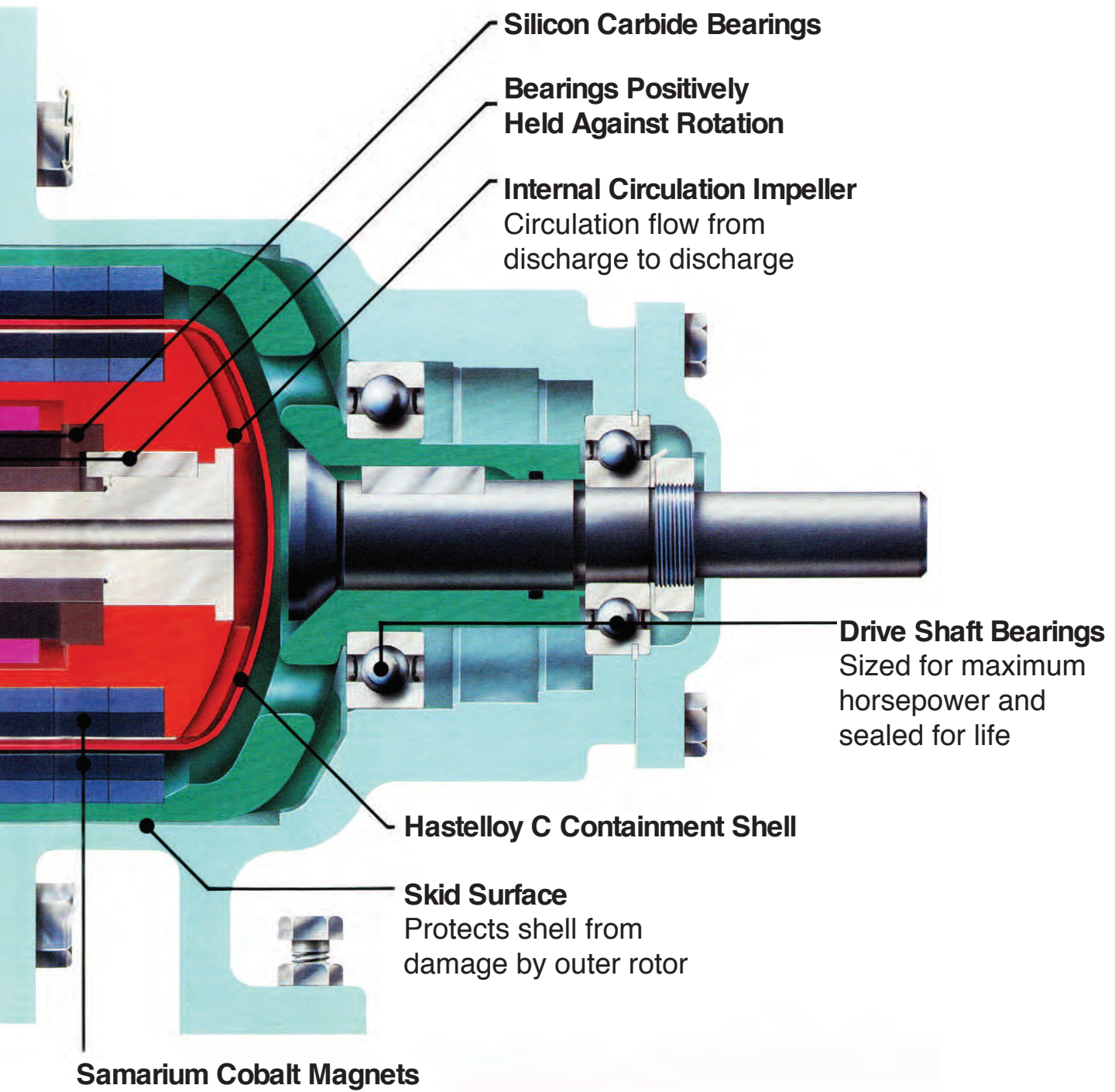

# **CECO Dean**

6040 Guion Road, Indianapolis, IN 46254  
Phone 317-293-2930  
Email: [infofhs@onececo.com](mailto:infofhs@onececo.com)  
[www.cecoenviro.com](http://www.cecoenviro.com)