

# CECO Dean

# DEAN PUMP® DEANLINE SERIES

Industrial In-line Centrifugal Pumps

INSTALLATION

OPERATION

MAINTENANCE MANUAL



**DO NOT INSTALL, OPERATE, OR SERVICE THIS PUMP  
BEFORE READING THE ENTIRE MANUAL**

# INDEX

Deanline Series	1
Mechanical Design Specifications	1
Standard Materials of Construction	1
Air Motor Option	1
Mechanical Seal Specifications	1
Caustic Service Option	1
Product Inspection and Test	2
Dean Pump Product Warranty	2
Warning	2
Spare Parts	2
Ordering Spare Parts	2
Installation and Maintenance	3
Application and Reapplication	3
Installation	3
Operation	3
Starting the Pump	3
Servicing	3
Disassembly Procedure	4
Resassembly Procedure	5

# DEANLINE SERIES

## MECHANICAL DESIGN SPECIFICATIONS

PUMP TYPE	DEANLINE
Direction of Rotation (Viewed from Motor End)	CW
Driver Rating	230/460 Volt, 3 Phase, 60 Cycle, NEMA C Flange, #143 TCZ Frame, Dean Standard Motor, 304SS shaft with standard shaft extension for jet motor. NEMA T3B temp. rating for Ex. Pr. motors. Ex. Pr. motors are Class I, Group D; Class II, Groups F & G
Horsepower Rating — Maximum @ 1750 rpm @ 3500 rpm @ RPM for air motor	1/2 HP 1, 1 1/2, and 2 HP 100 PSI air 4 HP @ 3000 RPM
Flanges ANSI Rating	Class 125, Cast Iron (Class 20) Class 150, 316SS (Class 50)
Impeller	Single Plane Dynamic Balance
Maximum Working Pressure	100 PSIG
Maximum Suction Pressure	Any part of Working Pressure
Hydrostatic Test Pressure	150 PSIG Cast Iron (Class 20); 200 PSIG 316SS (Class 50)
Pumping Temperature Minimum	-20°F Cast Iron (Class 20); -20°F 316SS (Class 50)
Maximum	220°F Cast Iron (Class 20); 220°F 316SS (Class 50)
Stuffing Box (Seal Chamber)	Integral Mechanical Seal only, internal seal face flushing all pumps

### STANDARD MATERIALS OF CONSTRUCTION

Part No.	Part Name	Class 20	Class 50
3	Impeller	C.I.	316SS
5	Casing	C.I.	316SS
5D	Casing Capscrew	ASTM A307 Steel	ASTM A307 Steel
7	Adapter Cradle	C.I.	C.I.
7G	Adapter Capscrews	1020 Steel	1020 Steel
22	Casing Back Cover	C.I.	316SS
37	Clearance Shim	Plastic	Plastic
77	Casing Gasket	Non-Asbestos	Non-Asbestos
95A	Stationary Seal Element Stationary Face Spring Holder Shaft Packing	Carbon 304SS Viton	Carbon 316SS 316SS Teflon
95B	Rotating Seal Face	Ceramic	Ceramic
375	Seal Dowel Pin	Not Required	316SS

### AIR MOTOR OPTION

For best performance and life of the air motor, we offer the following suggestions and accessories.

- 1) The exhaust silencer provided at no charge with the pump can impose sufficient back pressure so as to require as much as twenty psi additional inlet pressure. To eliminate this back pressure, we offer a muffler.
- 2) The speed of the motor is limited by the motor manufacturer to 3,000 RPM. Since the motor is generously sized, excess inlet pressure will cause it to overspeed. To limit the top speed and allow for full range control, a regulator and gauge are available.
- 3) For intermittent duty, frequent generous oilings at the two oiling ports are recommended. For more continuous operation, the automatic air line lubricator is recommended.
- 4) Air motor life is further enhanced by use of the filter.

#### Accessories

#### Connections

	In	Out
1) Silencer . . . . .	3/4" Male	3/4" Male
2) Pressure Regulator . . . . .	1/2" Female	1/2" Female
3) Line Lubricator . . . . .	1/2" Female	1/2" Female
4) Line Filter . . . . .	1/2" Female	1/2" Female

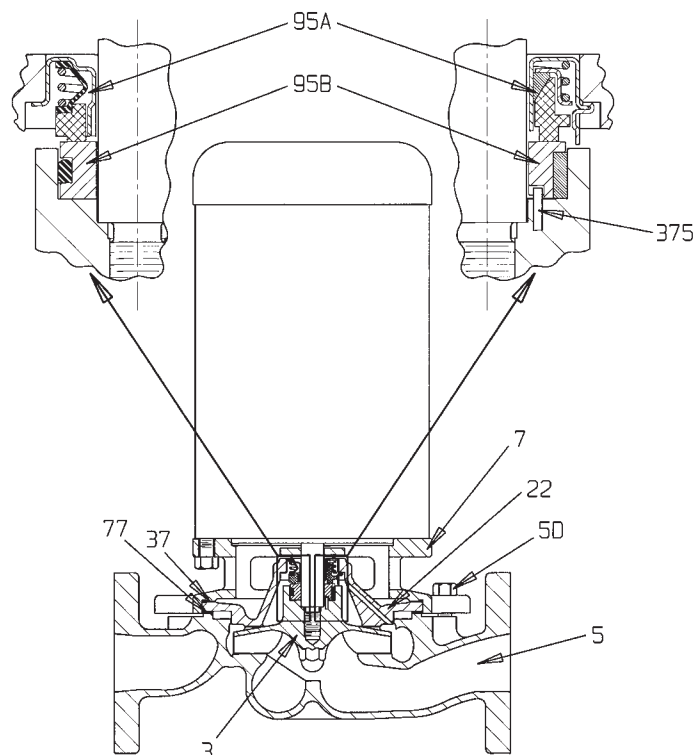

### MECHANICAL SEAL SPECIFICATIONS

Pump Material	Mechanical Seal	Suction Pressure		Temperature	
		Maximum	Minimum	Maximum	Minimum
CLASS 20 or 50	Dean Type 6A, 6C or 9A	100 PSIG	2 PSIA	220°F	-20°F

### CAUSTIC SERVICE OPTION

6C caustic seal is offered for Caustic Service: a 304SS seal with Ni-resist vs carbon faces and neoprene bellows.

Experience in the field has indicated the wisdom of establishing a limit to caustic soda (sodium hydroxide) liquid concentrations to 30% caustic in water and 175°F temperature.

Higher concentrations exhibit two related effects which have led to seal failures. First, crystallized solids in the pumpage immobilize the seal and leakage gets progressively worse although seal faces may appear undamaged. Secondly, the crystallization of leakage through the seal stops the seal from compensating for wear. The net effect in both cases is early seal failure.

If it is possible to flush the seal chamber with water, extended seal life is possible at higher caustic concentrations. This requires the addition of the flush hole in the pump backhead.

An external water source of sufficient pressure is necessary for the flush, warm water being more effective than cold water. The flush rate should be in the order of 1/2 gpm. The standard caustic seal should be used.

## PRODUCT INSPECTION AND TEST

The Products of Dean Pump Division are subject to thorough and rigorous quality control and inspection procedures throughout the

whole of the manufacturing process to assure proper operation in full conformity with established performance standards.

## DEAN PUMP PRODUCT WARRANTY

We warrant to the purchaser from us of Dean Pump products and parts of our own manufacture that the Dean Products are free under rated use and service from defects in design, material and workmanship for a period of one (1) year from the date of installation, but not to exceed eighteen (18) months from the date of shipment by us. This warranty does not cover (I) any loss or damage resulting from wear, corrosion, abrasion or deterioration due to normal use in rated service; (II) replacement of service items such as shaft packings and mechanical seals; (III) products or parts manufactured by others but furnished by us which, if defective, shall be repaired or replaced only to the extent of the original manufacturer's warranty; (IV) any loss or damage to or defects in any Dean Products resulting from the misuse or improper storage, installation, or operation thereof; or (V) any loss or damages to or defects in any Dean Products resulting from any alteration or modification thereof not expressly authorized and approved by us in writing. We shall not be liable, directly or indirectly, under any circumstances for consequential or incidental dam-

ages, including, but not limited, to: (I) any loss of business or profits; and (II) labor, material or other charges, claims, losses or damages incurred or suffered from, in connection with or in consequence of the working upon, alteration, or repair of any defective Dean Products by persons or firms other than us. Our liability for breach of warranty hereunder is limited solely to the repair in our factory or the replacement F.O.B. our factory, as the case may be, or any Dean Products which shall have been determined by us, after notice to us and inspection by us within the warranty period, to be so defective when shipped by us.

THIS WARRANTY AND THE LIABILITY SET FORTH HEREIN ARE EXCLUSIVE AND IN LIEU OF ALL OTHER LIABILITIES AND WARRANTIES, EXPRESSED OR IMPLIED, INCLUDING IMPLIED WARRANTIES OF MERCHANTABILITY AND FITNESS FOR PARTICULAR PURPOSE.

## WARNING

Proper storage while not in use and proper installation and startup are essential for successful pump operation. Misuse or improper storage, installation or operation of pumps may result in serious loss or damage. Dean Pump Division is not responsible for any loss or damage resulting from causes beyond its control, and is not liable for charges for work performed or materials furnished to repair such loss or damage.

***All installation, operation, and maintenance must be done by thoroughly qualified personnel in strict accordance with this manual and***

***must comply with all local, state and Federal codes. Only Dean authorized service parts must be used in the repair of these pumps.***

### RECEIVING PUMP

***When the pump is received from the transportation company, it should be promptly inspected for damage and such damage noted on the bill of lading before it is signed. Claims for shipping damage must be filed against the carrier.***

***Care must be exercised in unloading and handling the pump.***

## SPARE PARTS

To avoid prolonged down time and facilitate rapid repair of damaged pump parts, Dean Pump recommends that the pump user maintain a minimum stock of spare parts. If the pump service is critical or the pump parts are of special materials, a spare parts stock is even more important to the user. Such a spares inventory may extend from a spare mechanical seal or seal parts through complete backhead-impeller-motor assembly. Consult your Dean Pump representative who will assist you in selecting your spares stock.

### ORDERING SPARE PARTS

Spare part orders will be handled with a minimum delay if the following information is furnished by the customer with the order:

- 1) Give the pump number. This may be found on the pump name plate.
- 2) Give the part name, part number, and material of part. These should agree with the standard parts list nomenclature.
- 3) Give the quantity of each part required.
- 4) Give complete shipping instructions.

## INSTALLATION AND MAINTENANCE

Always wear the appropriate protective apparel when working on or around the pumping equipment. Safety glasses with side shields, heavy work gloves (use insulated work gloves when handling hot items), steel-toed shoes, hard hat, and any other protective gear as needed for protection. One example of other gear would be breathing apparatus when working near toxic materials. Use lifting devices, manufactured expressly for the purpose of lifting, to move the pumping machinery. Do not attempt to lift the assembly or its components manually. Use only devices with lifting capabilities in excess of the weight of the unit being lifted. Inspect straps, chains, hooks, etc. for damage and lifting capability before use. Lift only at the center of gravity.

Personal injury, death, and/or equipment damage could occur if good lifting practices are not used.

### APPLICATION AND REAPPLICATION

At the time of installation, the equipment received should have already been selected for the service required. You must read the paperwork for the installation and check the serial number of the pump to assure that you are installing the correct pump into the service for which it was selected.

Many pumps look identical from the outside but can be made of different materials and/or be constructed differently inside. Personal injury, death, equipment damage, product (pumpage) damage, and/or product loss could occur if the incorrect pump is installed.

Do not transfer an existing pump to any other service conditions until you have thoroughly reviewed the pump construction, materials, sizing, sealing, pressure containing capability, head/capacity capability, and temperature capability with respect to the required service. Consult your Dean Pump sales engineer with all the service requirements and a full description of the existing pump (including the serial number), seal, and sub-systems so that we can assist you in a successful reapplication.

### INSTALLATION

The DL Pump can be installed in any position. The pump is furnished with Class 125 in cast iron and Class 150 in 316 SS suction and discharge flanges cast in-line, maintaining simplified piping layouts. Suction lines should be short and straight to avoid excessive frictional losses. If larger piping is used on the suction side of the pump an eccentric reducer or means of venting the suction line should be provided to avoid the trapping of air or vapor. A centrifugal pump should be started with the suction valve open and the discharge valve either closed or opened a slight amount.

The pump seal chamber is arranged for mechanical seals only and no gland is required. Seals are installed at the factory and require no attention on installation or start-up of the pump.

### OPERATION

DL pump motors are furnished with the prelubricated ball bearings. No lubrication is required at start-up. When bearing replacement becomes necessary, install prelubricated, permanently sealed ball bearings.

### STARTING THE PUMP

1) A centrifugal pump should be started with the suction valve open and the discharge valve either closed or opened a slight amount.

2) When the source of liquid supplied to the pump is below atmospheric pressure or located below the pump, the pump must be primed prior to start-up.

*A centrifugal pump should never be run without liquid in the casing. Extensive damage may result, particularly to the mechanical seal.*

3) Check all piping connections, making certain that connections are to the correct openings and that all connections are tight.

4) Check the electrical connections.

5) It is most important to check the direction of rotation of the pump before allowing the pump to come up to speed. To check rotation direction, push the starting button and instantly push the stop button. This will allow the motor to run over a few revolutions and the direction of rotation to be observed. A direction of rotation arrow is shown on the side of the pump casing. If rotation direction is incorrect, change the wiring connections and recheck rotation. Operating the pump in reverse rotation may cause extensive damage.

6) After the pump is up to speed the discharge valve may be opened slowly. **WARNING—EXTREME HAZARD TO PERSONNEL: Do not operate a pump at no flow condition. Do not operate a pump at a low flow condition, unless provision has been made to prevent dangerous heat build up within the pump casing. At no flow and low flow conditions, without the above provision, the liquid in the pump will heat up and may result in a high pressure in a short time. This pressure may result in a rupture of the pressure containing parts of the pump or system and cause extreme hazard to personnel and damage to the system.**

### SERVICING

#### WARNING:

*Work must be performed only by thoroughly trained and qualified personnel to assure quality repair and to reduce the possibilities of injury to personnel and/or damage to equipment. If you do not have personnel who are capable of safe quality repair of this equipment, we advise you to return the equipment to DEAN PUMP to be repaired.*

*When it is necessary to open the pump and/or the pumping system the fluid will be exposed to the atmosphere and personnel in the area. For the safety of all involved, the risk of exposure of personnel to the hazards of the pumpage can be reduced by flushing the entire system with a compatible, nontoxic, non-hazardous, stable liquid before opening the pump or the system. In all cases, where the system is flushed or not, use the utmost care around the pumpage and the pumping system.*

*Always wear the appropriate protective apparel when working on or around the pumping equipment. Safety glasses with side shields, heavy work gloves (use insulated work gloves when handling hot items), steel-toed shoes, hard hat, and any other protective gear as needed for protection. One example of other gear would be breathing apparatus when working near toxic materials.*

*Use only top quality tools.*

a) Stop the pump. Turn off the power supply (electricity, air, etc.) to the pump driver (motor, turbine, engine, etc.) and lock the switching device so that it can not be restarted. Tag the switching device so that no one will attempt to restart the unit.

b) Close the suction and discharge valves completely to isolate the pump from the system. Lock the valves in the closed position and

tag them so that no one will attempt to open them.

- c) Turn off, lock out, and tag all sub-systems and auxiliary equipment and auxiliary supply lines to isolate the pumping unit from any and all power, energy, and/or fluids.

**WARNING:**

**Do not attempt to perform any work on the unit until you are confident that the pump and its contents have been stabilized at ambient temperature, and atmospheric pressure.**

**Put on protective wear to protect human tissue from attack by the fluids contained in the pump and any sub-systems, and from any vapors or fumes that could possibly be released from these fluids. This could mean breathing apparatus face shields, heavy long sleeve rubber gloves, rubber apron, hood, and possibly more, dependent, of course, on the properties of the fluids involved and the installed drain and vent piping arrangement. Personal injury and/or death can occur if adequate precautions are not taken with regard to the fluid, the installation and the possibilities of the release of fluid, vapors, and/or fumes.**

**DISASSEMBLY PROCEDURE**

- a) Always disconnect motor electrical leads, or air supply.
- b) Isolate pump casing to prevent spillage by closing suction and discharge valves.
- c) Carefully bleed off any pressure remaining in the pump. Pressure remaining in the pump will be dependent upon the pressure in the system when the pump was stopped; the quality, type, and condition of the isolation valves; the thermal expansion values of the fluid and the pump material; and the change in the vapor pressure of the fluid between the temperature at the time the isolation valves were closed and the ambient temperature. Bleeding must be through a valved drain line piped to a closed container mounted lower than the pump. The container must be arranged with a relief passage to some point where pressure and fumes will not be harmful to personnel. The container must also have a level device so that determination can be made that sufficient fluid has been drained to empty the pump cavity and the volume of fluid that was contained in the run of suction and discharge pipe between the isolation valves and the pump. After the initial rush of fluid from the pump relieves the pressure, the drain valve can be opened further to speed the draining operation. When fluid quits running into the drain tank, gage the volume to see if it is sufficient to have fully drained the contents of the pump and the suction and discharge pipes between the isolation valves.

If the system was constructed without any drain connections, it will be necessary to consult the designers of the system for safe draining procedures.

**WARNING:**

**Even though it might appear that the cavity being drained has completely drained, be extremely careful about opening the system and/or opening the pump. If something solid in the pumpage moves to the vicinity of the drain connection, it could seal-off the drain and maintain pressure in the cavity thought to have been drained. It is also possible that the isolation valves are not sealing and therefore allowing liquid to flow from the system into the pump. Personal injury, death and/or equipment damage may occur if great caution is not exercised.**

- d) Because of the above possibility, when you loosen the gasketed joint at the back of the casing (5), loosen the casing capscrews (5D) only one full turn, and then break the gasket seal. If fluid

and/or pressure remains in the pump it will spray out now. Use extreme caution, wearing protective gear, to avoid injury. Do not proceed with disassembly until leakage ceases completely. If leakage does not cease, the isolation valves may not be sealing. Note that the pump may contain fluid which will flow out at the time the capscrews are loosened and the gasket seal is broken.

**WARNING:**

**When you open the pump, the fluid will be exposed to the atmosphere and personnel in the area. For the safety of all involved, the risk of exposure can be reduced by flushing the cavity that was just drained with a compatible, non-toxic, non-hazardous, stable liquid, before disassembling the pump.**

- e) Remove the casing capscrews (5D) and using a mechanical lifting apparatus, lift the rotating unit from the casing (5).
- f) Flush the wetted parts, now exposed, with a compatible, non-toxic, non-hazardous, stable liquid.
- g) Remove the casing gasket (77) from the face of the casing (5) or the casing back cover (22) dependent on which one the gasket may have adhered to. The type of gasket and material of construction will vary with service requirements. Attack by prying and then, if necessary, layering off the old gasket with a sharp scraper, attempting to remove it in the largest possible pieces. Wear heavy leather, long sleeve work gloves when using the scraper. Be careful to not scar the gasket contact surfaces of the casing or the casing back cover. Wet the gasket before and during the scraping operation to reduce the possibility of fibers becoming airborne. Wear a respirator during this operation and until all debris has been disposed of in a plastic bag. Remove all of the gasket material down to clean metal surfaces on both parts that contacted the gasket. Place all of the gasket residue in a plastic bag, seal the bag and dispose.
- h) The rotating assembly of the pump can now be moved to a more convenient location for further disassembly. Use mechanical lifting equipment to move assemblies and components.

**WARNING:**

**Use only high quality tools.**

**Flush parts as disassembled to remove hazardous residue from the pumpage and/or sub-system fluids.**

**Wear protective equipment as advised at the beginning of this section.**

**Use mechanical lifting equipment to lift assemblies and components.**

**Do not apply heat to parts to assist in disassembly. Explosion could occur causing personal injury, death, and/or damage to equipment.**

**Do not attempt to drill, saw or otherwise cut parts to remove them. Explosion and/or fuming could occur causing personal injury, death, and/or equipment damage.**

**Do not hammer on any parts. Personal injury and/or damage to equipment may occur.**

- i) Remove the impeller (3). Hold the shaft against rotation by placing a large screw driver into the slot provided in the motor end of the shaft, and use a wrench on the impeller nut to back-off the impeller.
- j) Remove the casing back cover (22) from the adaptor cradle (7).
- k) Remove the shims (37) from the casing back cover (22) and/or the adaptor cradle (7)
- l) If the motor or the adaptor cradle (7) are to be replaced, remove the adaptor cradle (7) from the motor.

- m) Press the stationary seal element (95A) from the casing back cover (22). Pull the rotating seal face (95B) from the impeller (3).

**REASSEMBLY PROCEDURE**

**WARNING:**

*Use only high quality tools.*

*Wear protective equipment as advised at the beginning of this section.*

*Use mechanical lifting equipment to lift assemblies and components.*

*Do not hammer on any parts. Personal injury and/or damage to equipment may occur.*

*Do not attempt to manufacture parts or modify Dean Pump parts in any manner. Death, personal injury, and/or damage to equipment may occur.*

*Always replace the casing gasket (77), stationary seal element (95A), and rotating seal face (95B) with new parts.*

*Use only Dean Pump Met-Pro Corporation parts.*

To reassemble the pump, perform the following steps:

- a) Clean all parts thoroughly.
- b) If the adaptor cradle (7) was removed from the motor, place the adapter cradle (7) onto the motor. Install the four mounting screws into the motor and tighten them to 125 pound-inches of torque.
- c) If any of the following parts are being replaced; adaptor cradle (7), casing back cover (22), impeller (3), casing (5), and/or motor; go to step e).
- d) Place all of the clearance shims (37), that were removed during dis-assembly, into the adaptor cradle (7). Go to step j).
- e) Slide the casing back cover (22) over the motor shaft and into the adaptor cradle (7).

- f) Screw the impeller onto the motor shaft.
- g) Measure the clearance between the impeller (3) and the casing back cover (22), using a feeler gauge. Be sure that the casing cover is firmly against the adaptor cradle (7) when taking this measurement.
- h) Subtract 0.010" from the clearance measurement above and the resultant is the proper thickness of clearance shims (37) required for correct assembly.
- i) Remove the impeller (3) and the casing back cover (22). Place the clearance shim (37) stack, selected in step h) above, into the adaptor cradle (7).
- j) Press a new stationary seal element (95A) into the casing back cover (22).
- k) Install a new rotating seal face (95B) into the impeller (3). If the rotating seal face being used is mounted with a teflon seal (instead of a rubber seal), be careful to align the slot in the back side of the rotating seal with the seal dowel pin (375) in the impeller.
- l) Carefully slide the casing back cover (22) over the motor shaft and into the adaptor cradle (7).
- m) Screw the impeller (3) securely onto the motor shaft.
- n) The rotating assembly can now be taken to the installation site.
- o) Place a new casing gasket (77) onto the casing (5).
- p) Carefully lower the rotating assembly into the casing (5).
- q) Install the eight casing capscrews (5D) and tighten them, evenly, to 125 pound-inches torque.
- r) Go to the "Starting the Pump" section and follow the starting procedures. Caution: Be sure to check the motor rotation.

**ADDITIONAL NOTES**

---

---

---

---

---

---

---

---

---

---

---

---

---

---

---

---

---

---

---

---

---

---

---

---

---

---

# CECO Dean

6040 Guion Road • Indianapolis, IN 46254  
(317) 293-2930 • FAX: (317) 297-7028  
E-mail: infofhs@onececo.com • Web Site: www.cecoenviro.com

## READ WARNINGS

### HAZARDOUS SITUATIONS MAY OCCUR UNLESS THIS EQUIPMENT IS APPLIED, INSTALLED, OPERATED, AND MAINTAINED BY THOROUGHLY QUALIFIED PERSONNEL IN STRICT ACCORDANCE WITH THE INSTRUCTION MANUAL AND ALL APPLICABLE DRAWINGS AND CODES.

Read the instruction manual completely, before installing, filling, operating, or maintaining this equipment.

Obtain, read, and heed the MSDS (Material Safety Data Sheet) for the fluids being handled before attempting to fill, operate or maintain this equipment.

Obtain instructions from the Safety Engineer responsible for your facility before performing any work on the pumping equipment and systems.

**APPLICATION AND REAPPLICATION** - At the time of installation, the equipment received should have already been selected for the service required. You must read the paperwork for the installation and check serial number of the pump to assure that you are installing the correct pump into the service for which it was selected.

Many pumps look identical from the outside but can be made of different materials and/or be constructed differently inside. Personal injury, death, equipment damage, product (pumpage) damage, and/or product loss could occur if the incorrect pump is installed.

Do not transfer an existing pump to any other service conditions until you have thoroughly reviewed the pump construction, materials, sizing, sealing, pressure containing capability, head/capacity capability, and temperature capability with respect to the required service. Consult your DEAN PUMP sales engineer with all the service requirements and a full description of the existing pump (including the serial number), seal, and sub-systems so that we can assist you in a successful reapplication.

**INSTALLATION** - Always wear the appropriate protective apparel when working on or around the pumping equipment. Safety glasses with side shields, heavy work gloves (use insulated work gloves when handling hot items), steel toed shoes, hard hat, and any other protective gear as needed for protection. One example of other gear would be breathing apparatus when working near toxic materials.

Use lifting devices, manufactured expressly for the purpose of lifting, to move the pumping machinery. Do not attempt to lift the assembly or its components manually. Use only devices with lifting capabilities in excess of the weight of the unit being lifted. Inspect straps, chains, hooks, etc. for damage and lifting capability before use. Lift only at the center of gravity.

Personal injury, death, and/or equipment damage could occur if good lifting practices are not used.

Install the equipment on a properly designed and built foundation. Assure that the driver (motor, turbine, or engine) shaft is properly aligned to the pump shaft.

Connect the suction and discharge piping without forcing the piping into position. The pipe flanges must line up with the pump flanges "freely". Strain caused by "forcing" and/or misalignment may cause failure of the pumping unit, flanges, and/or the piping resulting in fluid (pumpage) release. This could cause personal injury, death and/or damage to this and/or other equipment.

Install a "new" bolt, of the correct size per ASME/ANSI B16.5 and the correct material per ASME/ANSI B16.5, in every bolt hole. Tighten all bolts evenly. Use only new uncorroded fasteners.

Improper flange bolting may cause failure of the pumping unit, flanges, piping, and/or fluid (pumpage) release which could cause personal injury, death, and/or damage to this and/or other equipment.

Connect all other (auxiliary) piping necessary for safe and successful operation of the equipment in the specific service conditions of the application. Make sure that all piping is installed into it's correct connection. Installation of a pipe into an incorrect location could result in an explosion and personal injury or death as well as damage to this and/or other equipment.

Install pressure relief valves in any cavities that could be subjected to pressures in excess of the allowable working pressure of that cavity. Explosion, personal injury, death, and/or damage to this and/or other equipment may occur if pressure exceeds allowable.

Recheck the alignment between the driver (motor, turbine, or engine) and pump shafts. Installation of piping may have forced the pump out of alignment. If so, correct the piping to remove the distorting load.

Check to be certain that the shaft coupling spacer is not installed, and then gently bump the motor starter to check the rotational direction of the motor. If this is not in the direction of rotation required for the pump, make the necessary corrections.

Lock-out the power to the driver (motor, turbine, engine, etc.)

Install the shaft coupling spacer. Be sure that you install all the retaining devices and bolts and that they are tight. Read and comply with the coupling manufacturer's instructions. Personal injury, death, and/or equipment damage could occur if the coupling spacer is not properly installed. Remove all debris and tools from the area near the shafts and the shaft coupling. Do this to assure that nothing is caught and thrown by the rotating parts when the pump is started. Bolt the coupling guard securely to the baseplate, checking to assure that it is not contacting any parts that will rotate when the pump is started.

**FILLING** - Before filling the pump with liquid, check to see that all possible leak locations are sealed. See that all of the connections into the pressure containing cavity are sealed or connected to a related piping system that also has all possible leak paths sealed. Do not plug unused jacket cavities, as this could develop dangerous pressure build-up. Use a wrench on all bolted joints to apply torque to assure that all gaskets are sealed in a tight joint. Check to see that all threaded pipe connections are also tight enough to seal the liquid pressure that will be applied when the system is started.

**OPERATING** - Before starting the unit, see that all personnel are a safe distance away from all possible hazards, that all sub-systems are connected and operating, that all debris has been removed, that the shaft coupling guard is securely in place, and that the pump is full of liquid.

Do not operate this pump at shut-off (no flow) as an explosion may result. This can occur with any liquid, even "cold water". Personal injury, death, equipment damage, and/or loss of product (pumpage) is likely to occur. If your system is operated where it is possible for all outlets for the discharge from the pump to be closed while the pump is still operating, a modification of the system needs to be made to assure a continual flow of pumpage through the pump. Note that some people have a belief that a bypass line from the discharge side of the pump to the suction side of the pump will relieve this problem, this is "NOT TRUE"; DO NOT ATTEMPT THIS.

**MAINTENANCE, DISASSEMBLY AND REPAIR** - Work must be performed only by thoroughly trained and qualified personnel to assure quality repair and to reduce the possibilities of injury to personnel and/or damage to equipment. If you do not have personnel who are capable of safe quality repair of this equipment, we advise you to return the equipment to DEAN PUMP to be repaired.

When it is necessary to open the pump and/or the pumping system, the fluid will be exposed to the atmosphere and personnel in the area. For the safety of all involved, the risk of exposure of personnel to the hazards of the pumpage can be reduced by flushing the entire system with a compatible non-toxic, non-hazardous, stable liquid before opening the pump or the system. In all cases, where the system is flushed or not, use the utmost care around the pumpage and the pumping system.

Always wear the appropriate protective apparel when working on or around the pumping equipment. Safety glasses with side shields, heavy work gloves (use insulated work gloves when handling hot items), steel-toed shoes, hard hat, and any other protective gear as needed for protection. One example of other gear would be breathing apparatus when working near toxic materials.

Use only top quality tools.

Stop the pump. Turn off the power supply (electricity, steam, etc.) to the pump driver (motor, turbine, engine, etc.) and lock the switching device so that it cannot be restarted. Tag the switching device so that no one will attempt to restart the unit.

Close the suction and discharge valves completely to isolate the pump from the system. Lock the valves in the closed position and tag them so that no one will attempt to open them.

Turn off, lock out, and tag all sub-systems and auxiliary equipment and auxiliary supply lines to isolate the pumping unit from any and all power, energy, and/or fluids.

Do not attempt to perform any work on the unit until you are confident that the pump and its contents have been stabilized at ambient temperature, and atmospheric pressure.

Put on protective wear to protect human tissue from attack by the fluids contained in the pump and any sub-systems, and from any vapors or fumes that could possibly be released from these fluids. This could mean breathing apparatus, face shields, heavy long sleeve rubber gloves, rubber apron, hood, and possibly more, dependent of course on the properties of the fluids involved and the installed drain and vent piping arrangement. Personal injury and/or death can occur if adequate precautions are not taken with regard to the fluid, the installation, and the possibilities of the release of fluid, vapors, and/or fumes.

Remove the coupling guard. Remove the coupling spacer.

Drain all the fluids from the auxiliary sub-systems (lubrication, cooling, heating, seal barrier, etc.) that are connected to the pump. Drain each fluid into a separate container. Use caution required for each fluid after reading the MSDS (Material Safety Data Sheet) for each.

Flush each sub-system with a compatible, non-toxic, non-hazardous, stable liquid. Drain into individual containers for each fluid. Disconnect and remove all auxiliary piping.

Carefully bleed off any pressure remaining in the pump. Pressure remaining in the pump will be dependent upon the pressure in the system when the pump was stopped; the quality, type, and condition of the isolation valves; the thermal expansion valves of the fluid and the pump material; and the change in the vapor pressure of the fluid between the temperature at the time the isolation valves were closed and the ambient temperature. Bleeding must be through a valved drain line piped to a closed container mounted lower than the pump. The container must be arranged with a relief passage to some point where pressure and fumes will not be harmful to personnel. The container must also have a level device so that determination can be made that sufficient fluid has been drained to empty the pump cavity and the volume of fluid that was contained in the run of suction and discharge pipe between the isolation valves and the pump. After the initial rush of fluid from the pump relieves the pressure, the drain valve can be opened further to speed the draining operation. When fluid quits running into the drain tank, gauge the volume to see if it is sufficient to have fully drained the contents of the pump and the suction and discharge pipes between the isolation valves.

If the system was constructed without any drain connections, it will be necessary to consult the designers of the system for safe draining procedures.

Now drain any small piping, that contains the fluid pumped, from all low points, into the same container used to drain the pump. Do not drain any other fluids (different than the pumpage) into this container as they may not be compatible. Personal injury, death, and/or equipment damage could occur.

Even though it might appear that, the cavity being drained has completely drained, be extremely careful about opening the system and/or opening the pump. If something solid in the pumpage moves to the vicinity of the drain connection, it could seal-off the drain and maintain pressure in the cavity thought to have been drained. It is also possible that the isolation valves are not sealing and therefore allowing liquid to flow from the system into the pump. Personal injury, death, and/or equipment damage may occur if intense caution is not exercised.

Because of the above possibility, when you loosen the gasketed joint at the back of the casing (5), loosen the bolts or nuts only one full turn, and then use jack screws to break the gasket seal. If fluid and/or pressure remains in the pump, it will spray out now. Use extreme caution, wearing protective gear, to avoid injury. Do not proceed with disassembly until leakage ceases completely. If leakage does not cease, the isolation valves may not be sealing. Note that if the pump was purchased with out a drain, the pump will contain fluid which will flow out at the time the bolts are loosened and the gasket seal is broken.

When you open the pump, the fluid will be exposed to the atmosphere and personnel in the area. For the safety of all involved, the risk of exposure can be reduced by flushing the cavity that was just drained, with a compatible non-toxic, non-hazardous, stable liquid, before disassembling the pump.

Remove the casing bolts or nuts and using mechanical lifting apparatus to support the weight, pull the rotating unit from the casing.

Flush the wetted parts now exposed with compatible, non-toxic, non-hazardous, stable liquid.

Remove the gasket from the face of the casing (5) or the bearing housing (26) dependent on which one the gasket may have adhered to. The type of gasket and material of construction will vary with service requirements. Attack by prying and then, if necessary, layering off the old gasket with a sharp scraper, attempting to remove it in the largest possible pieces. Wear heavy leather, long sleeve work gloves when using the scraper. Wet the gasket before and during the scraping operation to reduce the possibility of fibers becoming airborne. Wear a respirator during this operation and until all debris has been disposed of in a plastic bag. Remove all of the gasket material down to clean metal surfaces on both parts that contacted the gasket. Place all of the gasket residue in a plastic bag, seal the bag and dispose of it in compliance with all government requirements.

The rotating assembly of the pump can now be moved to a more convenient location for further disassembly. Use only high quality tools. Flush parts as disassembled to removed hazardous residue from the pumpage and/or sub-system fluids.

Wear protective equipment as advised at the beginning of these warnings.

Use mechanical lifting equipment to lift assemblies and components.

Do not apply heat to parts to assist in disassembly. Explosion could occur causing personal injury, death, and/or damage to equipment.

Do not attempt to drill, saw, or otherwise cut parts to remove them. Explosion and/or fuming could occur causing personal injury, death, and/or equipment damage.

Do not hammer on any parts. Personal injury and/or damage to equipment may occur.

Do not attempt to manufacture parts or modify Dean Pump parts in any manner. Death, personal injury, and/or damage to equipment may occur.

One example of the above would be overboring the seal chamber, which removes metal that is required to contain fluids. Removal of this metal reduces the pressure containing capability of the part, and may create a leak path through the part.

Replace all gaskets, seals, bearings, and lubricants. Replace all parts that have worn, corroded, eroded, or otherwise deteriorated.

Use only Dean Pump MetPro Corporation parts.