

CECO Dean

DEAN PUMP® SERIES PH/PHP

Horizontal Process Pumps

DATA PAK

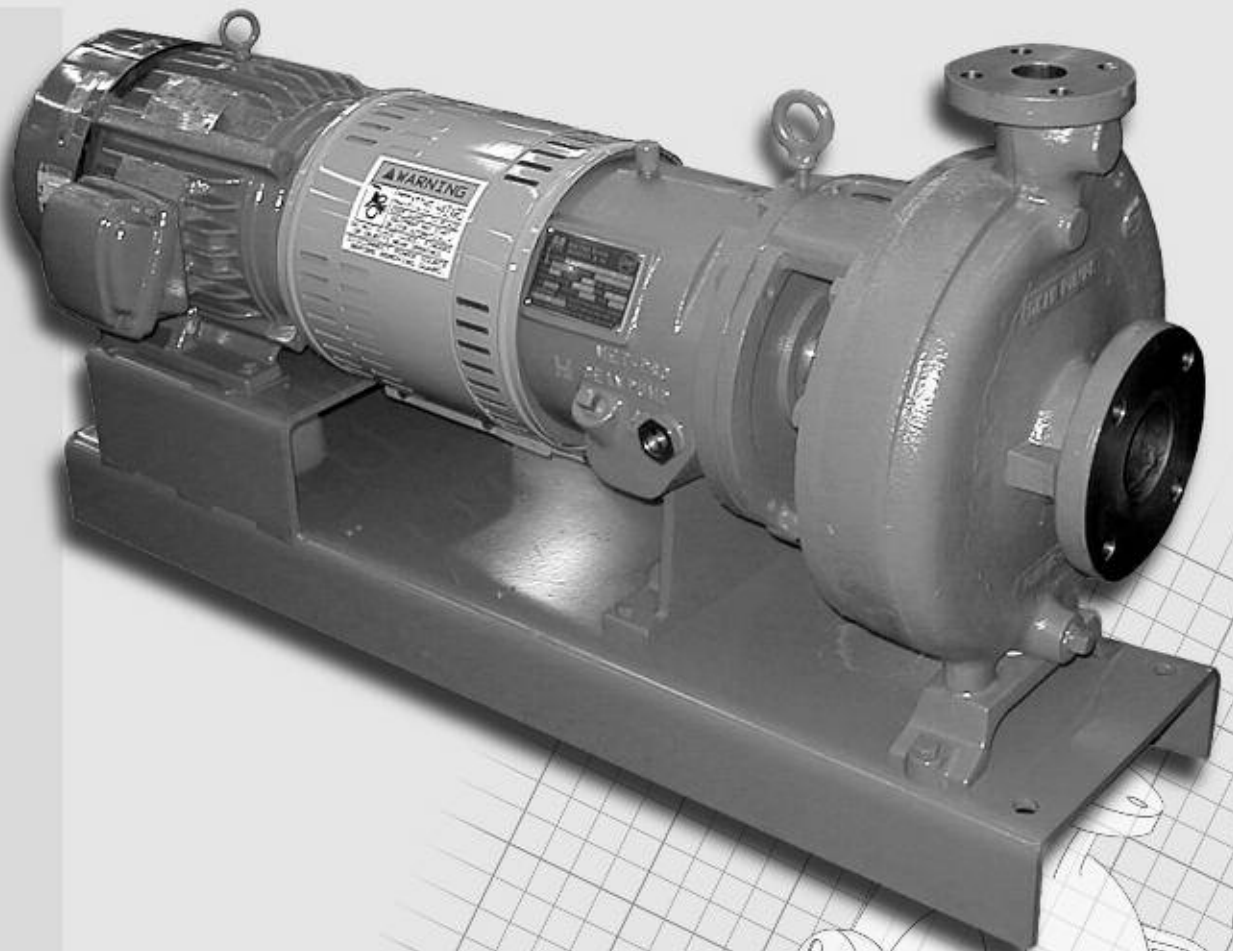

CECO Dean

6040 Guion Road, Indianapolis, IN 46254 USA
 Phone: 317-293-2930, Fax: 317-297-7028
 Email: info@onececo.com • Website: cecoenviro.com

SERIES PH
 HORIZONTAL PROCESS PUMPS

PH HEAD/CAPACITY RANGE CHARTS

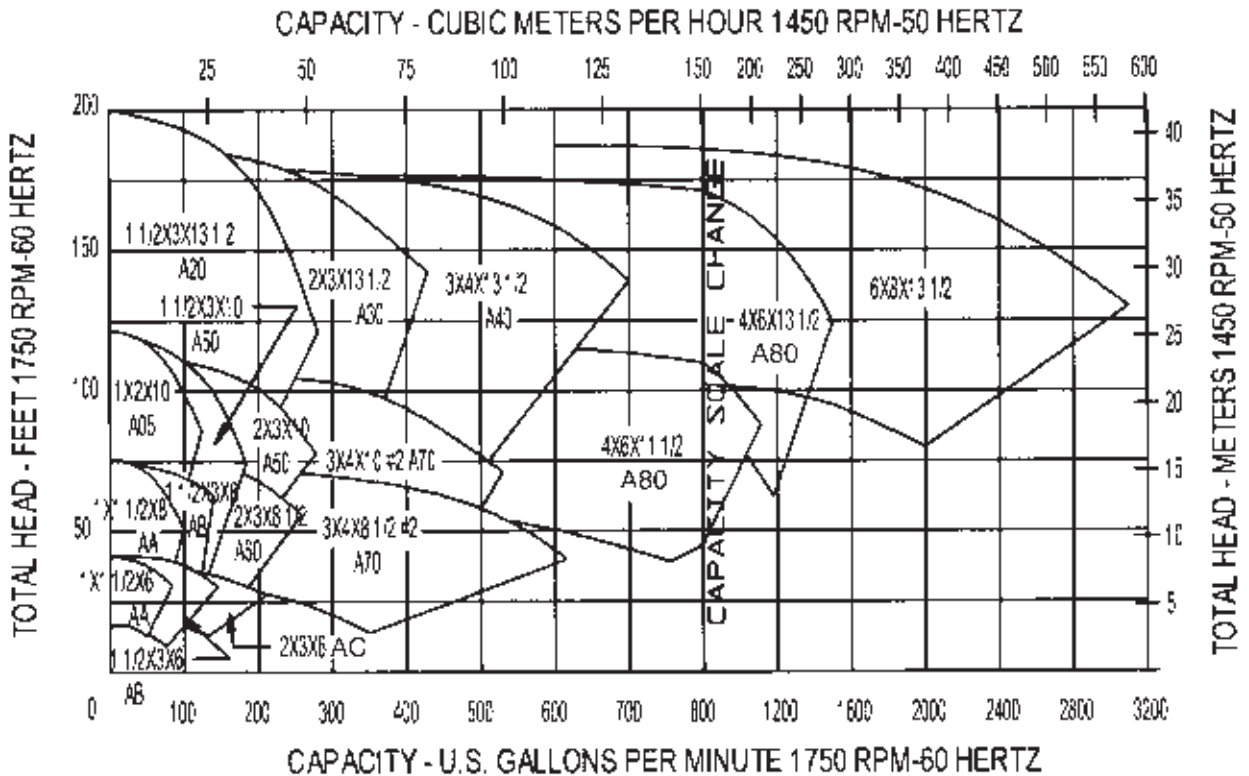
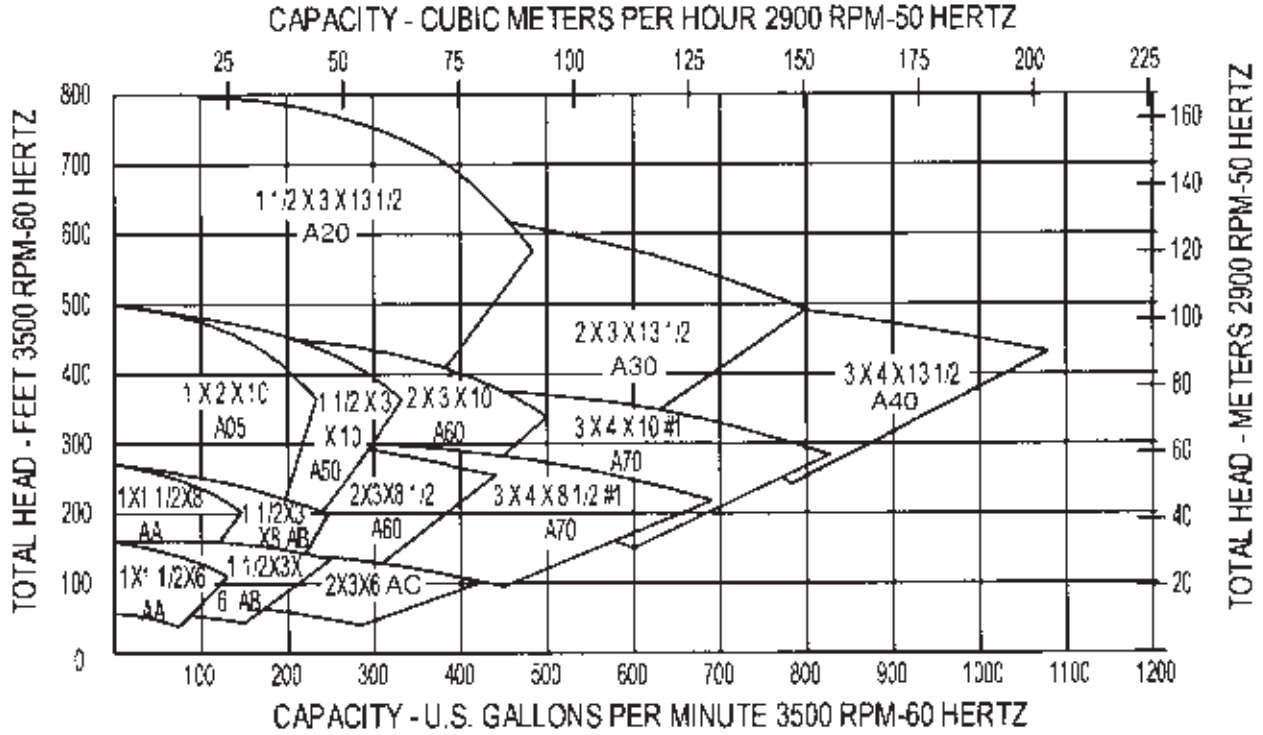

STANDARD, HORIZONTAL, SINGLE STAGE, END SUCTION, OPEN IMPELLER, CENTRIFUGAL PROCESS PUMPS

**pH2110 Series: Types pH2111, 2112, 2114, 2116, 2117, 2118 • pH2140 Series: Types pH2141, 2142, 2144, 2146, 2147, 2148
pH2170 Series: Types pH2171, 2172, 2174, 2176, 2177, 2178 • pH3170 Series: Types pH3171, 3172, 3174, 3176, 3177, 3178
pH2180 Series: Types pH2181, 2182, 2184, 2186, 2187, 2188**

MECHANICAL DESIGN SPECIFICATIONS					
PUMP TYPE	pH2110 pHP2110	pH2140 pHP2140	pH2170	pH3170	pH2180
Direction of Rotation (Viewed from Coupling End)	CW	CW	CW	CW	CW
Horsepower Rating @ 3500 rpm @ 1750 rpm @ 1150 rpm	35 HP 15 HP 10 HP	100 HP 40 HP 30 HP	— 100 HP 60 HP	200 HP 100 HP 60 HP	— 125 HP 75 HP
Hydrostatic Test Pressure	430 psig	430 psig	430 psig	565 psig	450 psig
Corrosion Allowance	1/8"	1/8"	1/8"	1/8"	1/8"
Impeller Balance	Single Plane Dynamic Balance				
Flanges ANSI Class Facing — standard — optional	150 F.F. R.F.	150 F.F. R.F.	150 F.F. R.F.	300 F.F. R.F.	300 F.F. R.F.
Finish	125 Ra	125 Ra	125 Ra	125 Ra	125 Ra
Stuffing box jacket pressure maximum Bearing housing cooler pressure maximum	125 psig 125 psig	125 psig 125 psig	125 psig 125 psig	125 psig 125 psig	125 psig 125 psig
Maximum Suction Pressure	275 psig	275 psig	275 psig	375 psig	300 psig
Bearings: Thrust Bearing Radial Bearing Lubrication	5306 6207 Oil	5309 6309 Oil	7311 BG 6311 Oil	7311 BG 6311 Oil	5312 6312 Oil
Approximate oil capacity of bearing housing	26 oz	42 oz	36 oz	36 oz	64 oz
Seal Chamber Dimensions: Tapered Seal Chamber Length (Depth) Inside Diameter (Bore) Shaft Sleeve Diameter	23/8" 27/8" 13/8"	31/16" 31/2" 13/4"	31/16" 37/8" 21/8"	31/16" 37/8" 21/8"	45/8" 41/4" 21/4"
Cylindrical Seal Chamber Length (Depth) Inside Diameter (Bore) Shaft Sleeve Diameter	17/8" 27/8" 13/8"	21/4" 31/2" 13/4"	23/16" 37/8" 21/8"	23/16" 37/8" 21/8"	35/16" 41/4" 21/4"
Stuffing Box Dimensions: Length (Depth) Inside Diameter (Bore) Shaft Sleeve Diameter Lantern Gland Width	21/8" 2" 13/8" 7/16"	23/4" 21/2" 13/4" 5/8"	23/4" 27/8" 21/8" 5/8"	23/4" 27/8" 21/8" 5/8"	37/8" 31/4" 21/4" 3/4"
Packing Size — Square Number of Rings with Lantern Ring Number of Rings without Lantern Ring Spacing with Lantern Ring	5/16" 5 6 2-G-3	3/8" 5 7 2-G-3	3/8" 5 7 2-G-3	3/8" 5 7 2-G-3	1/2" 6 7 3-G-3
Pump Shaft Dimensions: Span Between Bearings Span Between Radial Bearing and Impeller Diameter Under the Sleeve Diameter with No Sleeve Diameter at Coupling Diameter Between Bearings Diameter at Impeller	315/16" 513/16" 11/8" 13/8" 7/8" 11/2" 3/4"	63/8" 77/8" 13/2" 13/4" 11/8" 21/8" 11/4"	515/16" 83/16" 17/8" 21/8" 15/8" 25/8" 11/4"	515/16" 83/16" 17/8" 21/8" 15/8" 25/8" 11/4"	87/16" 103/4" 2" 21/4" 15/8" 23/4" 15/8"
L ³ /D ² Ratio Sleeved Shaft Solid Shaft (No Sleeve)	123 55	96 52	44 27	44 27	78 48

MAX. ALLOWABLE PUMP SUCTION PRESSURE (psi) WITH 2 YR. MIN. THRUST BEARING LIFE									
PUMP SIZE	With Balance Holes			Without Balance Holes			Values of Fn		
	3500 RPM	1750 RPM	1150 RPM	3500 RPM	1750 RPM	1150 RPM	3500 RPM	1750 RPM	1150 RPM
pH/pHP	maximum allowable suction pressure = maximum allowable discharge pressure less developed head						psi	psi	psi
1 x 1 1/2 x 6 pH2110 1 1/2 x 3 x 6 2 x 3 x 6 1 x 1 1/2 x 8 1 1/2 x 3 x 8 / 1 1/2 x 1 1/2 x 8							18	4.5	2.0
1 x 2 x 8 1/2 pH2140 1 1/2 x 3 x 8 1/2 2 x 3 x 8 1/2 3 x 4 x 8 1/2 #1 3 x 4 x 8 1/2 #2	110 115 110 110	185 185 185 180	200 200 200 210	180 190 195 200	180 195 205 230	205 205 205 205	25.2 25.2 25.2 39.0	6.3 6.3 6.3 9.7	2.7 2.7 2.7 4.2 4.2
1 x 2 x 10 1 1/2 x 3 x 10 / 2 x 2 10 2 x 3 x 10 / 3 x 3 x 10 3 x 4 x 10 #1 / 4 x 4 x 10 3 x 4 x 10 #2	110 110 110 110	180 180 180 180	200 200 200 210	185 195 185 205	195 205 205 205	205 205 205 205	25.2 25.2 25.5 25.2	6.3 6.3 6.3 6.3	2.7 2.7 2.7 2.7 4.2
1 1/2 x 3 x 11 1/2 2 x 3 x 11 1/2 3 x 4 x 11 1/2 4 x 6 x 11 1/2		105 105 170 150	180 180 200 200	180 180 190 200	180 180 200 205	200 200 200 205	25.2 25.2 14.0 14.0	6.3 6.3 6.0 6.0	2.7 2.7 6.0 6.0
1 1/2 x 3 x 13 1/2 2 x 3 x 13 1/2 3 x 4 x 13 1/2 / 4 x 4 x 13 1/2		165 165 165	195 195 195	185 185 185	185 200 200	200 200 200	25.2 25.2 25.2	6.3 6.3 6.3	2.7 2.7 2.7
4 x 6 x 13 1/2 pH2170		240	260	240	260			23	10.0
1 1/2 x 3 x 13 1/2 pH3170 2 x 3 x 13 1/2 3 x 4 x 13 1/2		300 300 285					25.2 25.2 25.2		
4 x 6 x 13 1/2 pH2180 6 x 8 x 13 1/2		225 225	275 275	275 275	275 275		22.0 15.0	10.0 6.7	

Seal Chamber Pressure:
With Balance Holes: seal chamber pressure = suction pressure
Without Balance Holes: Pumps are normally furnished without balance holes.
seal chamber pressure = (suction pressure) + (Fn x sp. gr.)

STANDARD MATERIALS OF CONSTRUCTION							
Part No.	Part Name	Class 22	Class 50	Class 60	CD4MCu	Hast.	Titanium
3	Impeller	C.I. (1)	316 (12)	Alloy20 (2)	CD4MCu	Hast.	Titanium
5	Casing	D.I. (10)	316 (12)	Alloy20 (2)	CD4MCu	Hast.	Titanium
5A	Casing Drain Plug	1020 Steel	316 S/S	Alloy20	316 S/S	Hast.	Titanium
5C	Casing Stud Nut	Ⓞ			Steel (4)		
5D	Casing Capscrew Casing Stud	Ⓞ▲† Ⓞ			Steel (11) Steel (6)		
7	Cradle Spacer	Ⓞ×†			D.I. (13)		
7G	Spacer to Brg. Hsg. Capscr.	Ⓞ†×†			1020 Steel		
9	Bearing Housing Foot	Ⓞ			C.I. (1)		
10	Shaft Sleeve	▲†×†	316 S/S	Alloy 20	316 S/S	Hast.	Titanium
10K	Sleeve Key	▲†×†			304 S/S		
13	Seal Chamber Gland		316 S/S	Alloy 20	316 S/S	Hast.	Titanium
14	Gland Stud		304 S/S	Alloy 20	304 S/S	Hast.	Titanium
15	Gland Nut		304 S/S	Alloy 20	304 S/S	Hast.	Titanium
17	Lantern Ring	Ⓞ▲†			Teflon ■		
	Lantern Ring	Ⓞ×†	C.I. (1)	316 S/S	Alloy 20		
22	Casing Back Cover	×†	D.I. (10)	316 (12)	Alloy 20 (2)	CD4MCu	Hast. Titanium
22A	Back Cover to Cradle Capscrew	▲†×†			1020 Steel		
25	Radial Bearing	▲†×†	—	—	—	—	—
25A	Thrust Bearing	▲†×†	—	—	—	—	—
26	Bearing Housing	†×†	D.I. (13) for pH2110 & pHP2110, C.I. (1) for all others				
27	Seal Ring	Ⓞ†×†			C.I. (1)		
28	Bearing End Cover	▲†×†			C.I. (1)		
28A	Bearing End Cover Capscrew	▲†×†			1020 Steel		
28B	End Cover Adjusting Screw	▲†×†			1020 Steel		
28C	Adjusting Screw Locking Nut	▲†×†			1020 Steel		
29	Pump Shaft	▲†×†			Steel (5)		
31	Thrust Bearing Lock Nut	Ⓞ†×†			1020 Steel		
31A	Thrust Bearing Lock Washer	Ⓞ†×†			1020 Steel		
56	Casing Foot	Ⓞ			C.I. (1)		
56A	Casing Foot Capscrew	Ⓞ†			1020 Steel		
56B	Casing Foot Dowel	Ⓞ†			1020 Steel		
75A	Tapered Retaining Ring	Ⓞ▲			Steel		
75B	Large Retaining Ring	Ⓞ▲†			Steel		
76	Labyrinth Seal — Front	▲†×†			Bronze & Viton ■		
76A	Labyrinth Seal — Rear	▲†×†			Bronze & Viton ■		
77	Casing Gasket	×†			Teflon ■		
77A	Impeller Gasket	▲†×†			Teflon ■		
77B	End Cover Gasket	▲†×†			Buna (7)		
80	Vent	▲†×†			—		
83	Motor Support (C Face)	Ⓞ▲†			C.I. (1)		
95A	Mechanical Seal Stationary	▲†×†					
95B	Mechanical Seal Rotary	▲†×†					
109	Oil Cooler	▲†×†			S/S Tubing with Steel Fins and Steel Fittings		
231	Bearing Lock Ring	Ⓞ×†			1020 Steel		
231A	Bearing Lock Ring Screw	Ⓞ×†			1020 Steel		
231B	Bearing Lock Ring Washer	Ⓞ×†			1020 Steel		

- ① pH2140, pH2170, pH3170, pH2180 and pHP2140 only
- ② pH2110, pH2140, pH2170, pH2180, pHP2110 and pHP2140 only
- ③ pH2110, and pHP2110 only
- ④ pH2170, pH3170, and pH2180 only
- ⑤ pH2140 and pHP2140 only
- ⑥ pH3170 only
- ⑦ pH2110, pH2140, pHP2110, and pHP2140 only
- ▲ Denoted parts are interchangeable in all pH2110 and pHP2110 pumps
- † Denoted parts are interchangeable in all pH2140 and pHP2140 pumps
- × Denoted parts are interchangeable in all pH2170 and pH3170 pumps
- † Denoted parts are interchangeable in all pH2180 pumps
- Registered Trademark of the E.I. DuPont Company

MATERIAL SPECIFICATIONS (REFER TO NUMBERS IN PARENTHESES)

- (1) Cast Iron
- (2) Alloy 20 S/S: ASTM #A744, Grade CN-7M
- (3) Cast Steel: ASTM #A216, Grade WCB
- (4) Steel: ASTM #A194, Grade 2
- (5) Alloy Steel: 125,000 TS, 100,000 YP
- (6) Steel: ASTM #A193, Grade B7
- (7) Buna "N" Rubber
- (8) Fibre Sheet — Non-Asbestos Fibre
- (9) Manila Paper
- (10) Ductile Iron: ASTM A395
- (11) Steel: ASTM #A449
- (12) 316 S/S: ASTM #A744 Grade CF-8M
- (13) Ductile Iron: ASTM A536

MAXIMUM ALLOWABLE WORKING PRESSURE CURVES

PH2110, PH2140, PH2170, PHP2110, PHP2140

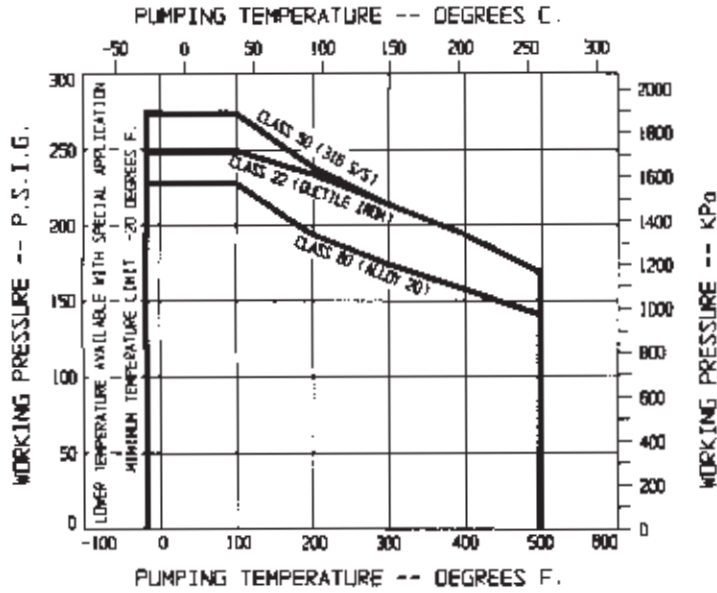

PH3170

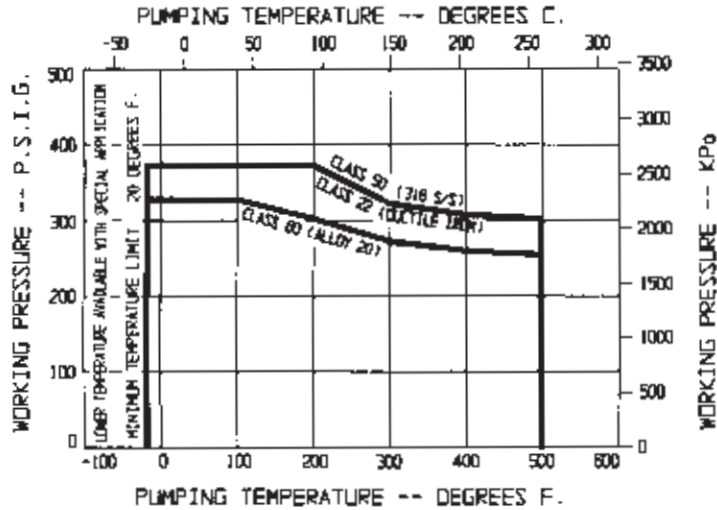

PH2180

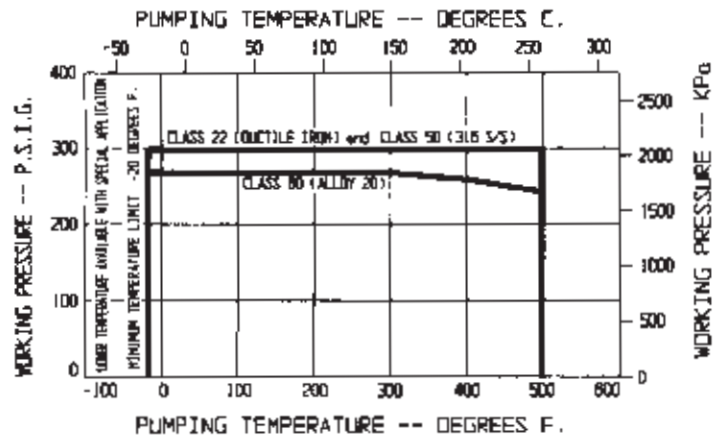

PH2110

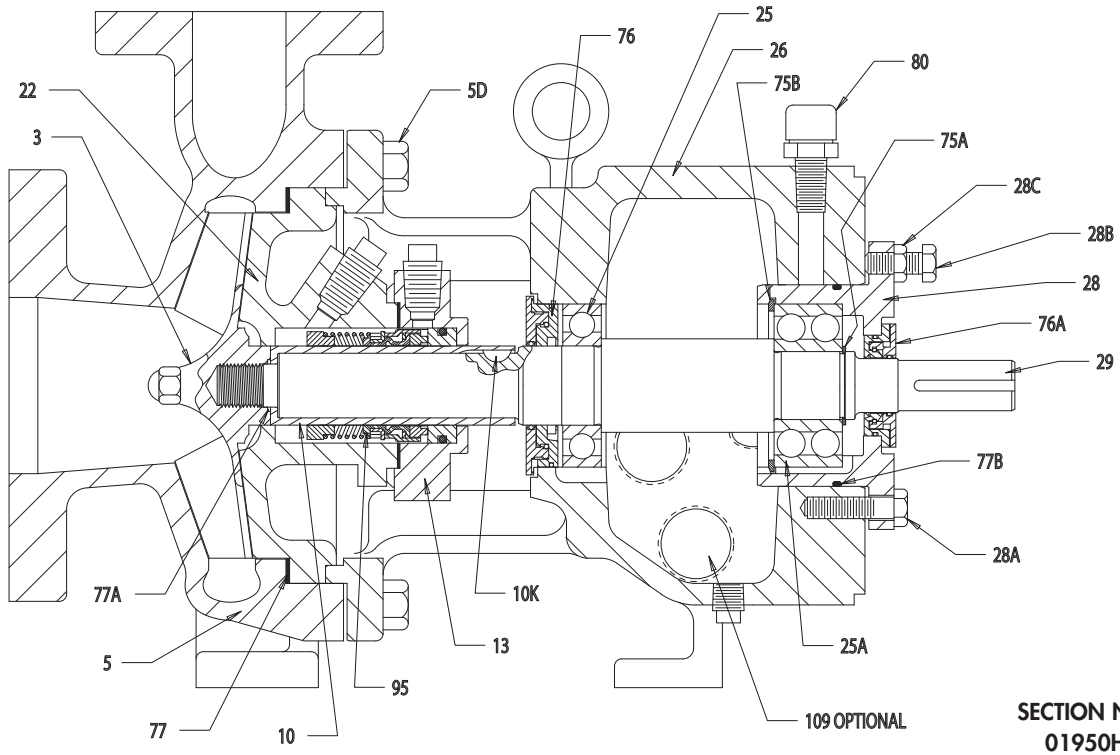

SECTION NO.
01950H

PH2140

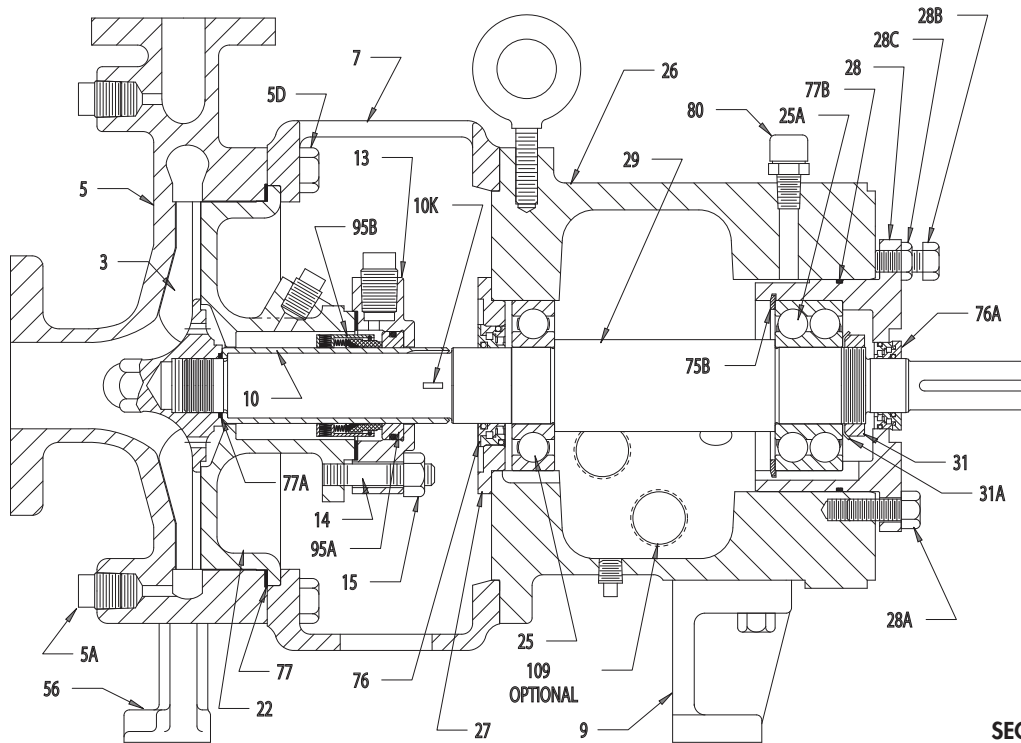

SECTION NO.
01916AA

PH2170/PH3170

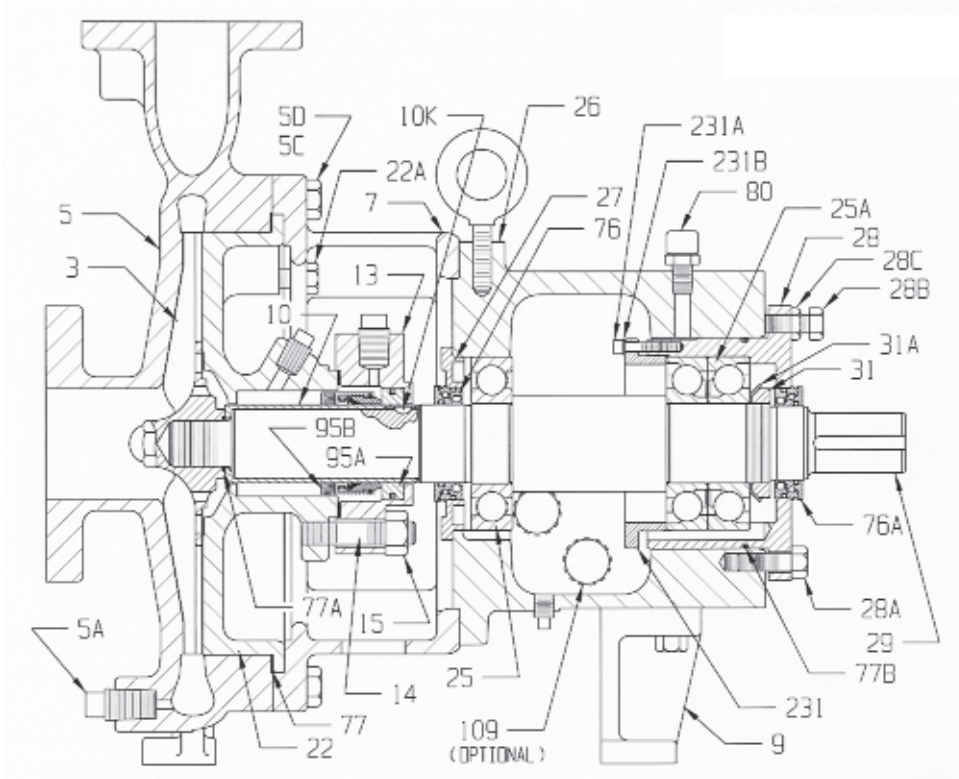

SECTION NO.
01946F

PH2180

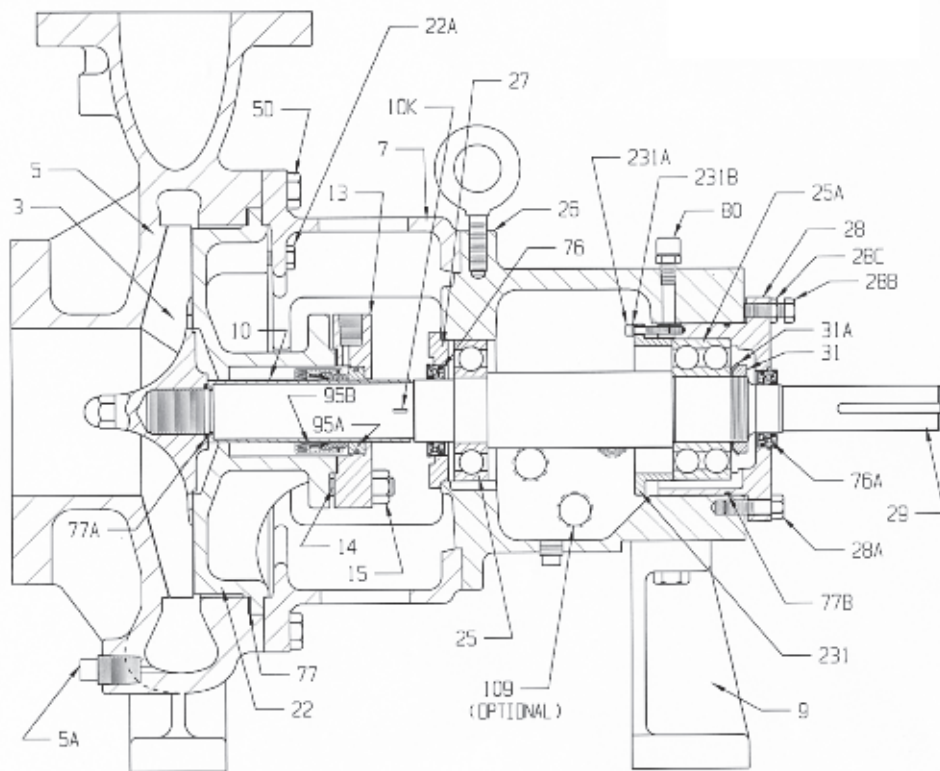

SECTION NO.
01938F

TYPE PH2110 SERIES
 STANDARD, END SUCTION, OPEN IMPELLER, CENTRIFUGAL PROCESS PUMPS

FLANGES:
 A.N.S.I. RATING . . . Class 150
 FACING Flat
 FINISH 125 Ra

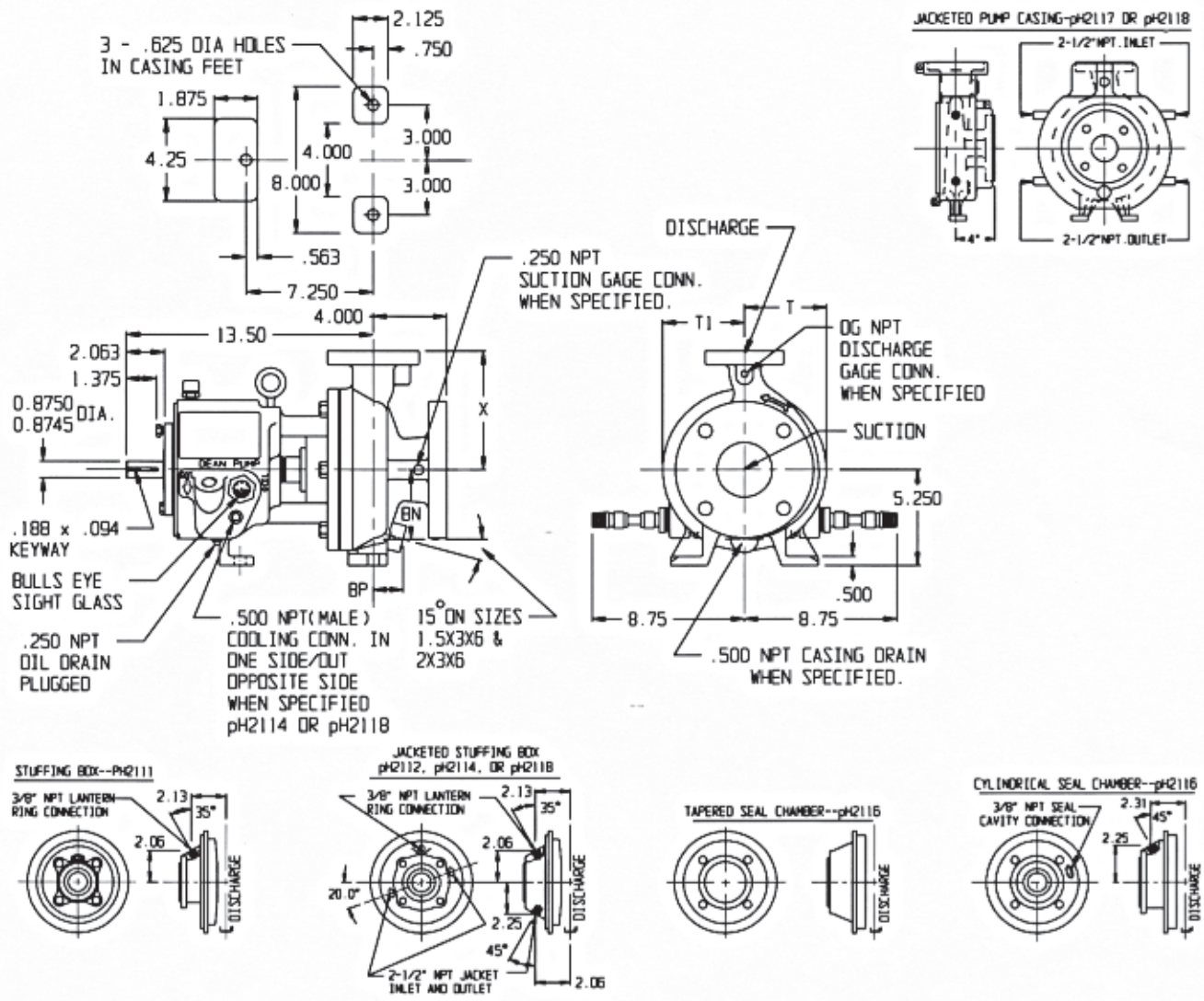

All dimensions in inches

ANSI SIZE	PUMP SIZE	DISCHARGE					SUCTION					X	BN	BP	DG
		SIZE	O.D.	THK	B.C.	BOLTS	SIZE	O.D.	THK	B.C.	BOLTS				
AA	1x1 ¹ / ₂ x6	1	4.25	.563	3.13	4-1/2	1.5	5	.688	3.88	4-1/2	6.50	3.19	1.75	.25
	1x1 ¹ / ₂ x8	1	4.25	.563	3.13	4-1/2	1.5	5	.688	3.88	4-1/2	6.50	4.25	1.50	.25
AB	1 ¹ / ₂ x3x6	1.5	5	.688	3.88	4-1/2	3	7.50	.938	6	4-5/8	6.50	3.94	1.97	.38
	1 ¹ / ₂ x3x8	1.5	5	.688	3.88	4-1/2	3	7.50	.938	6	4-5/8	6.50	4.38	1.63	.38
AC	2x3x6	2	6	.750	4.75	4-5/8	3	7.50	.938	6	4-5/8	7	4.06	2.19	.38

IMPORTANT: Do not use for construction unless certified.

DIMENSION DWG.
 NO. PH2044

TYPE PH2110 SERIES
STANDARD, END SUCTION, OPEN IMPELLER, CENTRIFUGAL PROCESS PUMPS WITH "ECONOMY" BASEPLATE

FLANGES:
A.N.S.I. RATING ... Class 150
FACING Flat
FINISH 125 Ra

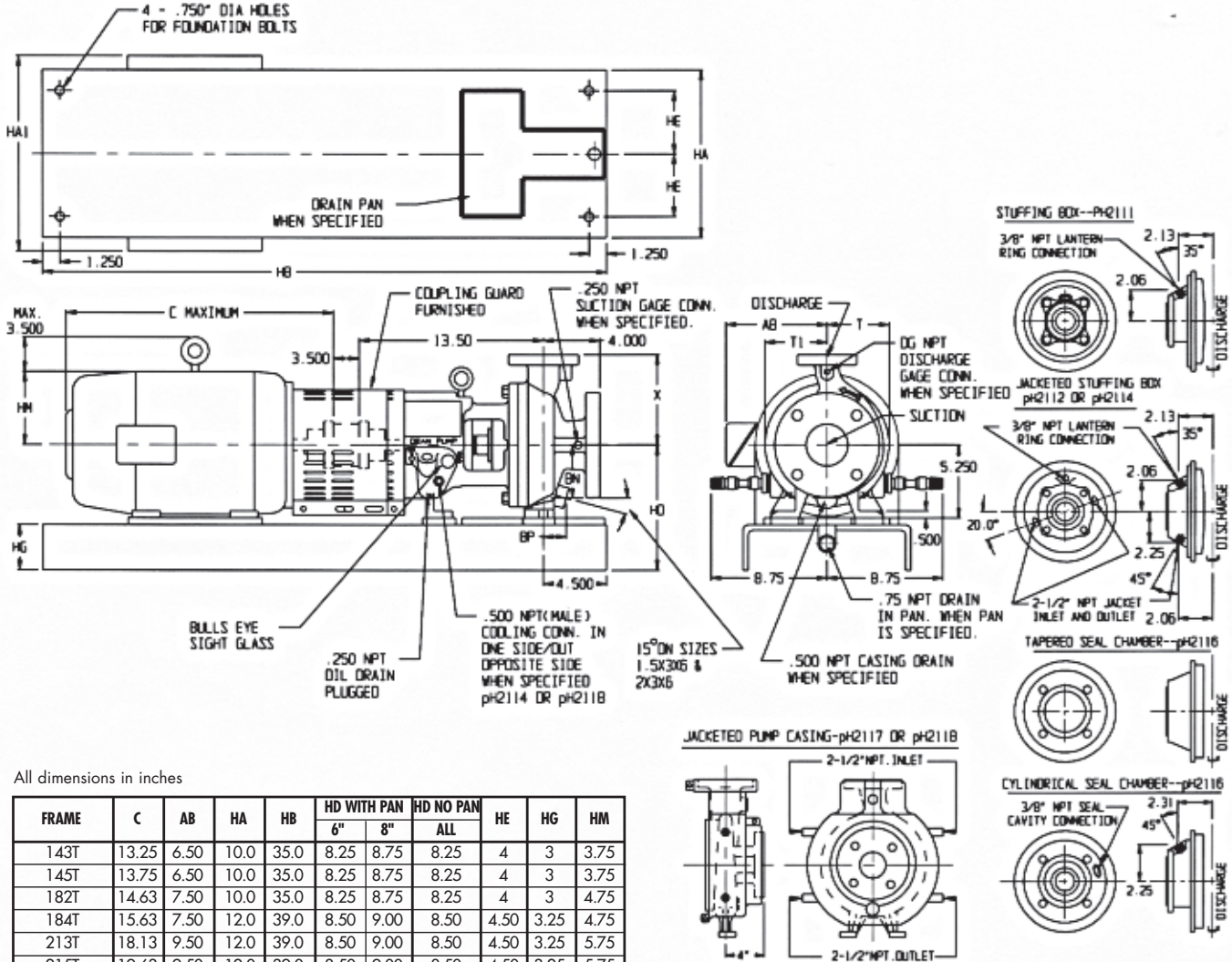

All dimensions in inches

FRAME	C	AB	HA	HB	HD WITH PAN		HD NO PAN ALL	HE	HG	HM
					6"	8"				
143T	13.25	6.50	10.0	35.0	8.25	8.75	8.25	4	3	3.75
145T	13.75	6.50	10.0	35.0	8.25	8.75	8.25	4	3	3.75
182T	14.63	7.50	10.0	35.0	8.25	8.75	8.25	4	3	4.75
184T	15.63	7.50	12.0	39.0	8.50	9.00	8.50	4.50	3.25	4.75
213T	18.13	9.50	12.0	39.0	8.50	9.00	8.50	4.50	3.25	5.75
215T	19.63	9.50	12.0	39.0	8.50	9.00	8.50	4.50	3.25	5.75
254T	23.13	11.0	15.0	52.0	10.50	10.50	10.50	6	4.13	7.00
256T	24.88	11.0	15.0	52.0	10.50	10.50	10.50	6	4.13	7.00
284TS	25.50	12.63	15.0	52.0	11.25	11.25	11.25	6	4.13	7.75
286TS	27.00	12.63	15.0	52.0	11.25	11.25	11.25	6	4.13	7.75
324TS	28.38	14.75	12.0	45.0	13.75	12.50	13.75	4.50	3.75	8.75

ANSI SIZE	PUMP SIZE	DISCHARGE					SUCTION					X	BN	BP	DG
		SIZE	O.D.	THK	B.C.	BOLTS	SIZE	O.D.	THK	B.C.	BOLTS				
AA	1x1 1/2x6	1	4.25	.563	3.13	4-1/2	1.5	5	.688	3.88	4-1/2	6.50	3.19	1.75	.25
	1x1 1/2x8	1	4.25	.563	3.13	4-1/2	1.5	5	.688	3.88	4-1/2	6.50	4.25	1.50	.25
AB	1 1/2x3x6	1.5	5	.688	3.88	4-1/2	3	7.50	.938	6	4-5/8	6.50	3.94	1.97	.38
	1 1/2x3x8	1.5	5	.688	3.88	4-1/2	3	7.50	.938	6	4-5/8	6.50	4.38	1.63	.38
AC	2x3x6	2	6	.750	4.75	4-5/8	3	7.50	.938	6	4-5/8	7	4.06	2.19	.38

IMPORTANT: Do not use for construction unless certified.

DIMENSION DWG.
NO. PH2043

TYPE PH210 TO SERIES
STANDARD, END SUCTION, OPEN IMPELLER, CENTRIFUGAL PROCESS PUMPS WITH "ANSI" BASEPLATE

FLANGES:
A.N.S.I. RATING ... Class 150
FACING Flat
FINISH 125 Ra

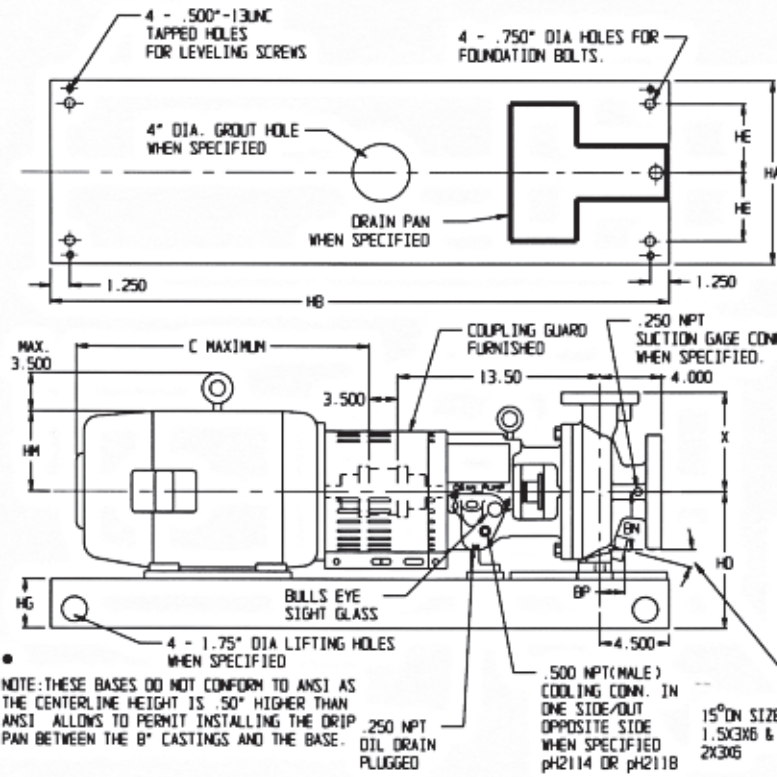

NOTE: THESE BASES DO NOT CONFORM TO ANSI AS THE CENTERLINE HEIGHT IS .50\"/>

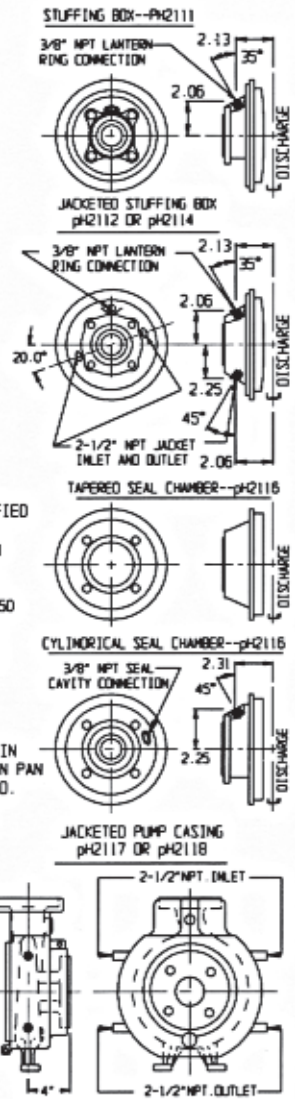

All dimensions in inches

FRAME	ANSI BASE #	C	AB	HA	HB	HD WITH PAN		HD NO PAN ALL	HE	HG	HM
						6"	8"				
143T	139	13.25	6.50	15.0	39.0	9.00	9.50*	9.00	4.50	3.75	3.75
145T	139	13.75	6.50	15.0	39.0	9.00	9.50*	9.00	4.50	3.75	3.75
182T	139	14.63	7.50	15.0	39.0	9.00	9.50*	9.00	4.50	3.75	4.75
184T	139	15.63	7.50	15.0	39.0	9.00	9.50*	9.00	4.50	3.75	4.75
213T	148	18.13	9.50	18.0	48.0	10.50	10.50	10.50	6	4.13	5.75
215T	148	19.63	9.50	18.0	48.0	10.50	10.50	10.50	6	4.13	5.75
254T	148	23.13	11.0	18.0	48.0	10.50	10.50	10.50	6	4.13	7.00
256T	148	24.88	11.0	18.0	48.0	10.50	10.50	10.50	6	4.13	7.00
284TS	153	25.50	12.63	21.0	53.0	12.88	12.88	12.88	7.50	4.75	7.75
286TS	153	27.00	12.63	21.0	53.0	12.88	12.88	12.88	7.50	4.75	7.75
324TS	153	28.38	14.75	21.0	53.0	12.88	12.88	12.88	7.50	4.75	8.75

ANSI SIZE	PUMP SIZE	DISCHARGE					SUCTION					X	BN	BP	DG
		SIZE	O.D.	THK	B.C.	BOLTS	SIZE	O.D.	THK	B.C.	BOLTS				
AA	1x1 1/2x6	1	4.25	.563	3.13	4-1/2	1.5	5	.688	3.88	4-1/2	6.50	3.19	1.75	.25
	1x1 1/2x8	1	4.25	.563	3.13	4-1/2	1.5	5	.688	3.88	4-1/2	6.50	4.25	1.50	.25
AB	1 1/2x3x6	1.5	5	.688	3.88	4-1/2	3	7.50	.938	6	4-5/8	6.50	3.94	1.97	.38
	1 1/2x3x8	1.5	5	.688	3.88	4-1/2	3	7.50	.938	6	4-5/8	6.50	4.38	1.63	.38
AC	2x3x6	2	6	.750	4.75	4-5/8	3	7.50	.938	6	4-5/8	7	4.06	2.19	.38

IMPORTANT: Do not use for construction unless certified.

DIMENSION DWG.
NO. PH2045

TYPE PH2110 SERIES
STANDARD, END SUCTION, OPEN IMPELLER, CENTRIFUGAL PROCESS PUMPS WITH "C" FLANGE ADAPTOR
FOR MOTOR FRAMES: 143TC, 145TC, 182TC, 184TC, 213TC, AND 215TC

FLANGES:
A.N.S.I. RATING ... Class 150
FACING Flat
FINISH 125 Ra

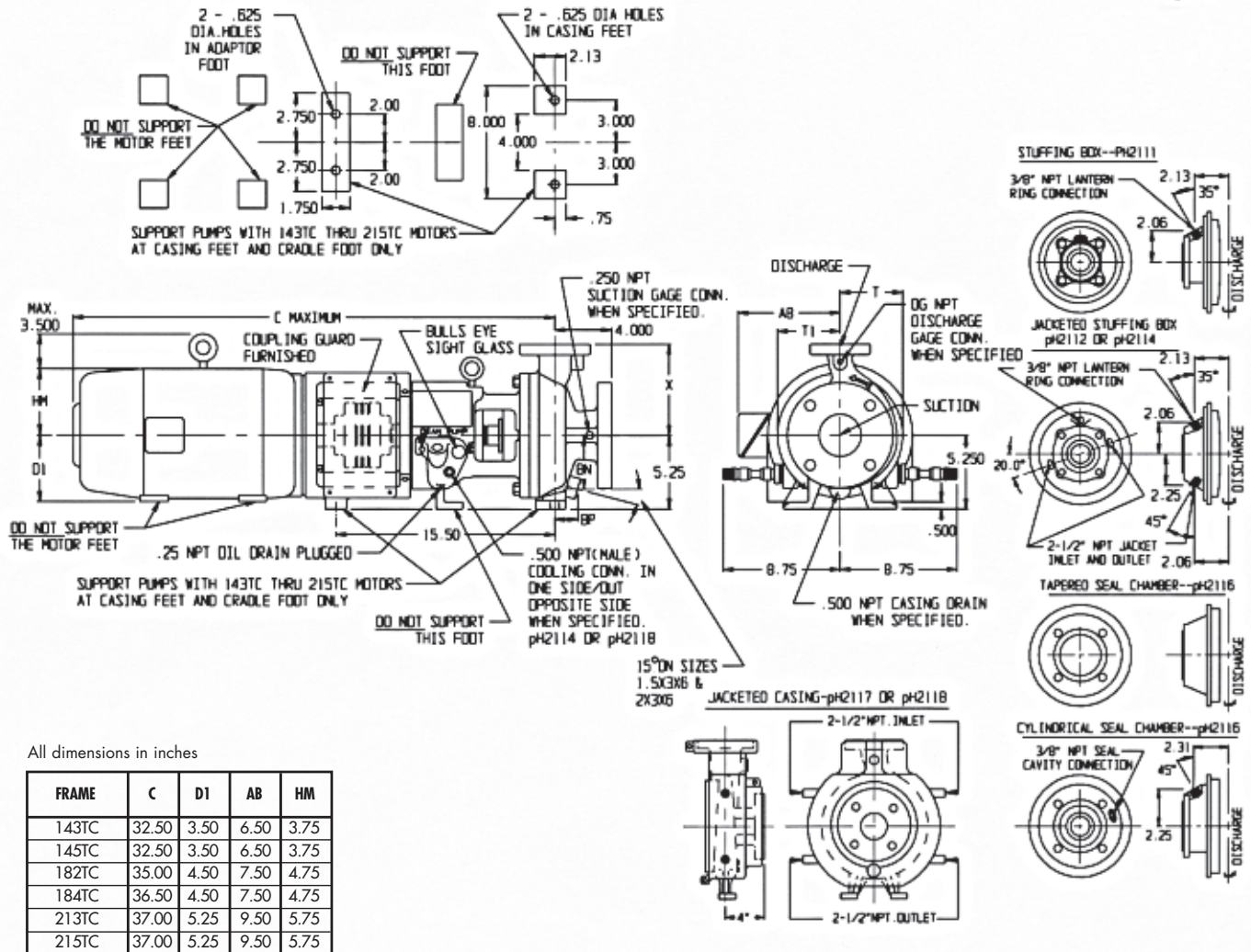

All dimensions in inches

FRAME	C	D1	AB	HM
143TC	32.50	3.50	6.50	3.75
145TC	32.50	3.50	6.50	3.75
182TC	35.00	4.50	7.50	4.75
184TC	36.50	4.50	7.50	4.75
213TC	37.00	5.25	9.50	5.75
215TC	37.00	5.25	9.50	5.75

ANSI SIZE (WITHOUT "C" ADAPTOR)	PUMP SIZE	DISCHARGE					SUCTION					X	BN	BP	DG
		SIZE	O.D.	THK	B.C.	BOLTS	SIZE	O.D.	THK	B.C.	BOLTS				
AA	1x1 1/2x6	1	4.25	.563	3.13	4-1/2	1.5	5	.688	3.88	4-1/2	6.50	3.19	1.75	.25
	1x1 1/2x8	1	4.25	.563	3.13	4-1/2	1.5	5	.688	3.88	4-1/2	6.50	4.25	1.50	.25
AB	1 1/2x3x6	1.5	5	.688	3.88	4-1/2	3	7.50	.938	6	4-5/8	6.50	3.94	1.97	.38
	1 1/2x3x8	1.5	5	.688	3.88	4-1/2	3	7.50	.938	6	4-5/8	6.50	4.38	1.63	.38
AC	2x3x6	2	6	.750	4.75	4-5/8	3	7.50	.938	6	4-5/8	7	4.06	2.19	.38

TYPE PH2110 SERIES
STANDARD, END SUCTION, OPEN IMPELLER, CENTRIFUGAL PROCESS PUMPS WITH "C" FLANGE ADAPTOR
FOR MOTOR FRAMES: 254TC AND 256TC

FLANGES:
A.N.S.I. RATINGClass 150
FACINGFlat
FINISH125 Ra

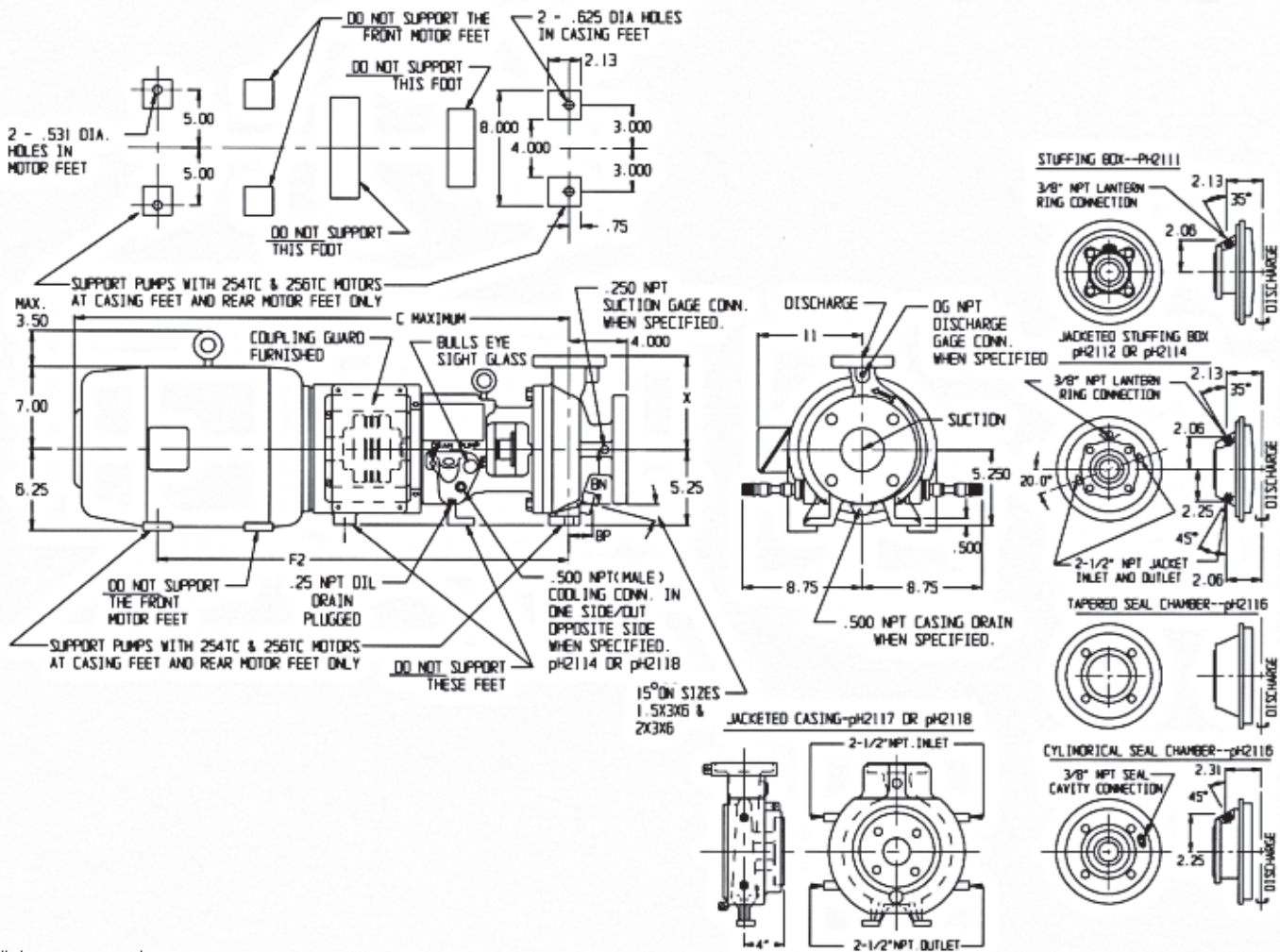

All dimensions in inches

FRAME	C	F2
254TC	39.00	30.50
256TC	41.00	32.25

ANSI SIZE (WITHOUT "C" ADAPTOR)	PUMP SIZE	DISCHARGE					SUCTION					X	BN	BP	DG
		SIZE	O.D.	THK	B.C.	BOLTS	SIZE	O.D.	THK	B.C.	BOLTS				
AA	1x1 1/2x6	1	4.25	.563	3.13	4-1/2	1.5	5	.688	3.88	4-1/2	6.50	3.19	1.75	.25
	1x1 1/2x8	1	4.25	.563	3.13	4-1/2	1.5	5	.688	3.88	4-1/2	6.50	4.25	1.50	.25
AB	1 1/2x3x6	1.5	5	.688	3.88	4-1/2	3	7.50	.938	6	4-5/8	6.50	3.94	1.97	.38
	1 1/2x3x8	1.5	5	.688	3.88	4-1/2	3	7.50	.938	6	4-5/8	6.50	4.38	1.63	.38
AC	2x3x6	2	6	.750	4.75	4-5/8	3	7.50	.938	6	4-5/8	7	4.06	2.19	.38

IMPORTANT: Do not use for construction unless certified.

DIMENSION DWG.
NO. PH2041

TYPE PH2110 SERIES
STANDARD, END SUCTION, OPEN IMPELLER, CENTRIFUGAL PROCESS PUMPS WITH "ECONOMY" BASEPLATE
AND "C" FLANGE ADAPTOR

FLANGES:
A.N.S.I. RATING . . . Class 150
FACING Flat
FINISH 125 Ra

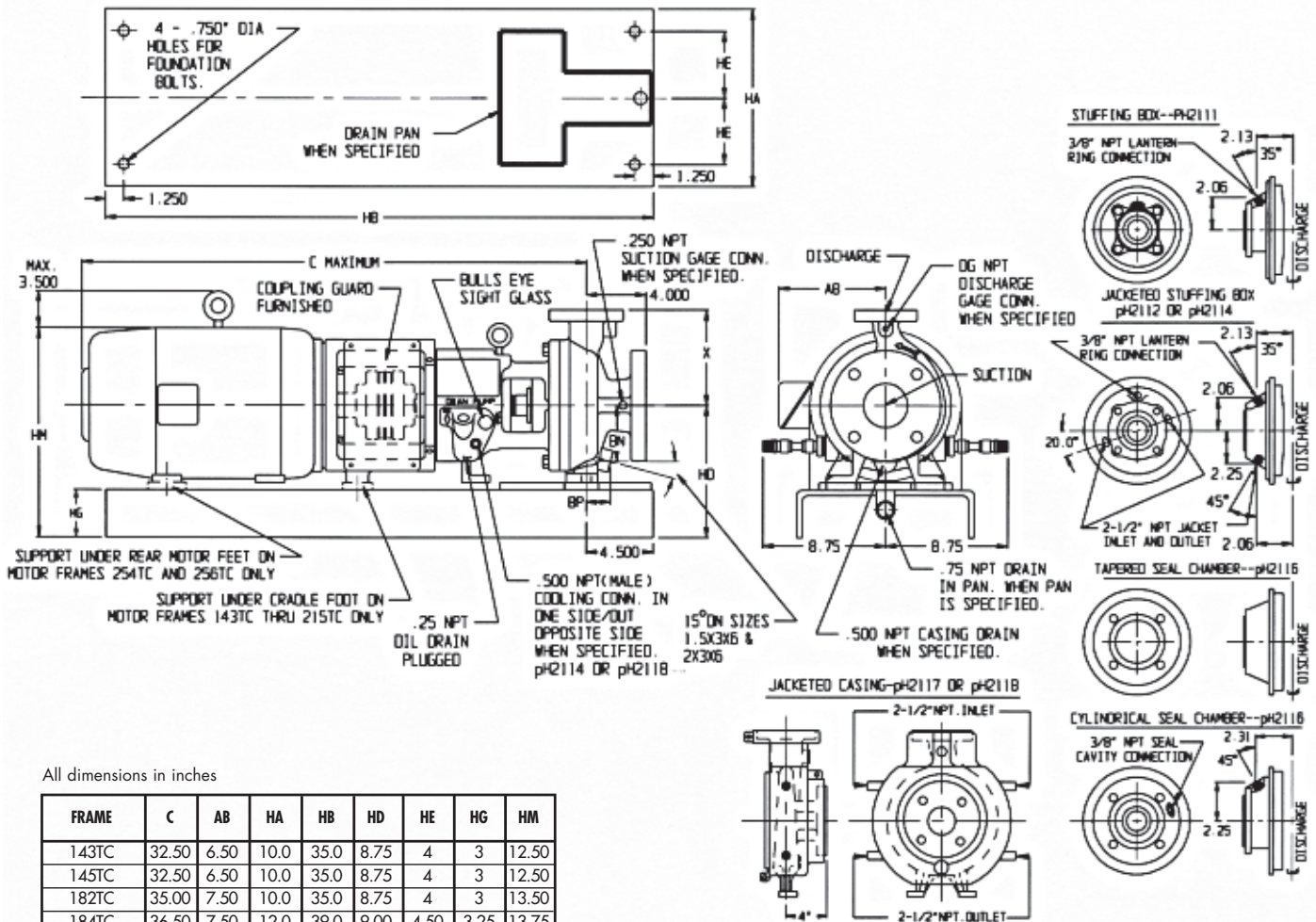

All dimensions in inches

FRAME	C	AB	HA	HB	HD	HE	HG	HM
143TC	32.50	6.50	10.0	35.0	8.75	4	3	12.50
145TC	32.50	6.50	10.0	35.0	8.75	4	3	12.50
182TC	35.00	7.50	10.0	35.0	8.75	4	3	13.50
184TC	36.50	7.50	12.0	39.0	9.00	4.50	3.25	13.75
213TC	37.00	9.50	12.0	39.0	9.00	4.50	3.25	14.75
215TC	37.00	9.50	12.0	39.0	9.00	4.50	3.25	14.75
254TC	39.00	11.00	15.0	52.0	11.00	6	4.13	17.88
256TC	41.00	11.00	15.0	52.0	11.00	6	4.13	17.88

ANSI SIZE	PUMP SIZE	DISCHARGE						SUCTION					X	BN	BP	DG
		SIZE	O.D.	THK	B.C.	BOLTS	SIZE	O.D.	THK	B.C.	BOLTS					
AA	1x1 1/2x6	1	4.25	.563	3.13	4-1/2	1.5	5	.688	3.88	4-1/2	6.50	3.19	1.75	.25	
	1x1 1/2x8	1	4.25	.563	3.13	4-1/2	1.5	5	.688	3.88	4-1/2	6.50	4.25	1.50	.25	
AB	1 1/2x3x6	1.5	5	.688	3.88	4-1/2	3	7.50	.938	6	4-5/8	6.50	3.94	1.97	.38	
	1 1/2x3x8	1.5	5	.688	3.88	4-1/2	3	7.50	.938	6	4-5/8	6.50	4.38	1.63	.38	
AC	2x3x6	2	6	.750	4.75	4-5/8	3	7.50	.938	6	4-5/8	7	4.06	2.19	.38	

IMPORTANT: Do not use for construction unless certified.

DIMENSION DWG.
NO. PH2042

TYPE PH2140 SERIES
STANDARD, END SUCTION, OPEN IMPELLER, CENTRIFUGAL PROCESS PUMPS

FLANGES:
A.N.S.I. RATING . . . Class 150
FACING Flat
FINISH 125 Ra

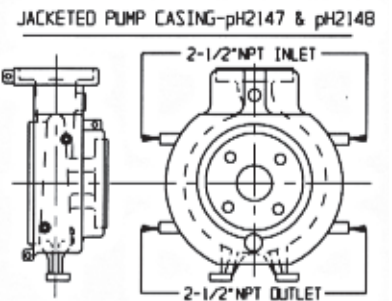
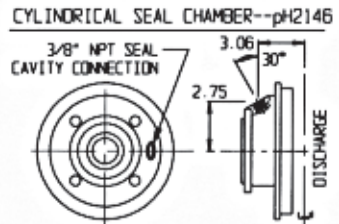
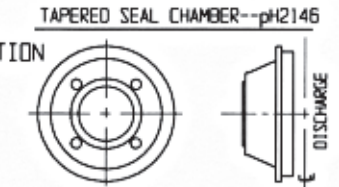
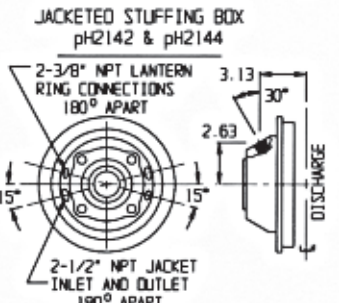
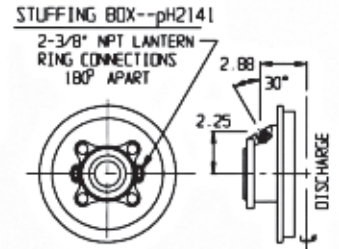
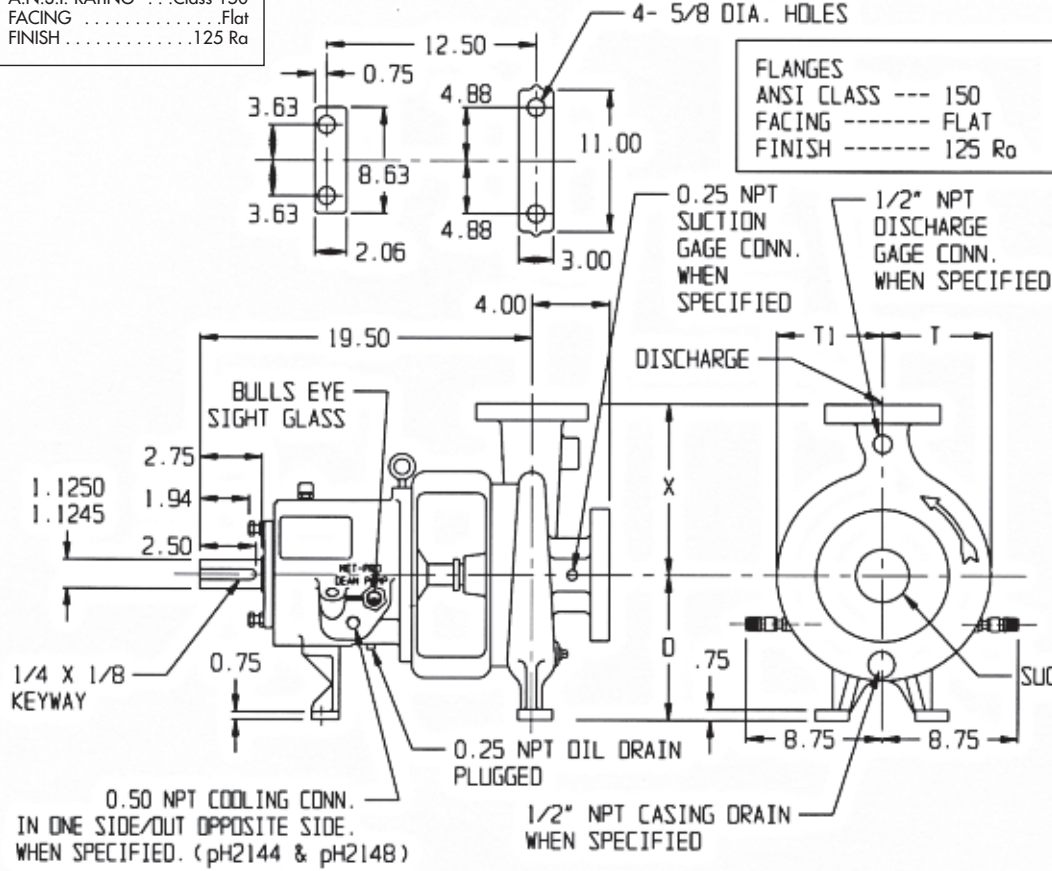

All dimensions in inches

ANSI SIZE	PUMP SIZE	DISCHARGE					SUCTION					D	X	T	T1
		SIZE	O.D.	THK	B.C.	BOLTS	SIZE	O.D.	THK	B.C.	BOLTS				
A05	1x2x8 1/2	1	4.25	.563	3.13	4-1/2	2	6	.750	4.75	4-5/8	8.25	8.50	5.75	5.75
A50	1 1/2x3x8 1/2	1.5	5	.688	3.88	4-1/2	3	7.50	.938	6	4-5/8	8.25	8.50	5.88	5.75
A60	2x3x8 1/2	2	6	.750	4.75	4-5/8	3	7.50	.938	6	4-5/8	8.25	9.50	6.25	5.75
A70	3x4x8 1/2 #1	3	7.50	.938	6	4-5/8	4	9	.938	7.50	8-5/8	8.25	11	7	6.13
	3x4x8 1/2 #2	3	7.50	.938	6	4-5/8	4	9	.938	7.50	8-5/8	8.25	11	7.63	6.38
A05	1x2x10	1	4.25	.563	3.13	4-1/2	2	6	.750	4.75	4-5/8	8.25	8.50	5.75	5.75
A50	1 1/2x3x10	1.5	5	.688	3.88	4-1/2	3	7.50	.938	6	4-5/8	8.25	8.50	6.25	6.25
A60	2x3x10	2	6	.750	4.75	4-5/8	3	7.50	.938	6	4-5/8	8.25	9.50	6.75	6.25
A70	3x4x10 #1	3	7.50	.938	6	4-5/8	4	9	.938	7.50	8-5/8	8.25	11	7.38	6.38
	3x4x10 #2	3	7.50	.938	6	4-5/8	4	9	.938	7.50	8-5/8	10	11.75	8.50	7.38
A20	1 1/2x3x11 1/2	1.5	5	.688	3.88	4-1/2	3	7.50	.938	6	4-5/8	10	10.50	7.63	7.13
A30	2x3x11 1/2	2	6	.750	4.75	4-5/8	3	7.50	.938	6	4-5/8	10	11.50	8.25	7.50
A40	3x4x11 1/2	3	7.50	.938	6	4-5/8	4	9	.938	7.50	8-5/8	10	12.50	9	8
A80	4x6x11 1/2	4	9	.938	7.50	8-5/8	6	11	1	9.50	8-3/4	10	13.50	9.75	8.25
A20	1 1/2x3x13 1/2	1.5	5	.688	3.88	4-1/2	3	7.50	.938	6	4-5/8	10	10.50	8.25	8.25
A30	2x3x13 1/2	2	6	.750	4.75	4-5/8	3	7.50	.938	6	4-5/8	10	11.50	8.75	8.25
A40	3x4x13 1/2	3	7.50	.938	6	4-5/8	4	9	.938	7.50	8-5/8	10	12.50	9.38	8.50

IMPORTANT: Do not use for construction unless certified.

DIMENSION DWG.
NO. PH2145

TYPE PH2140 SERIES
STANDARD, END SUCTION, OPEN IMPELLER, CENTRIFUGAL PROCESS PUMPS WITH "ECONOMY" BASEPLATE

FLANGES:
A.N.S.I. RATINGClass 150
FACINGFlat
FINISH125 Ra

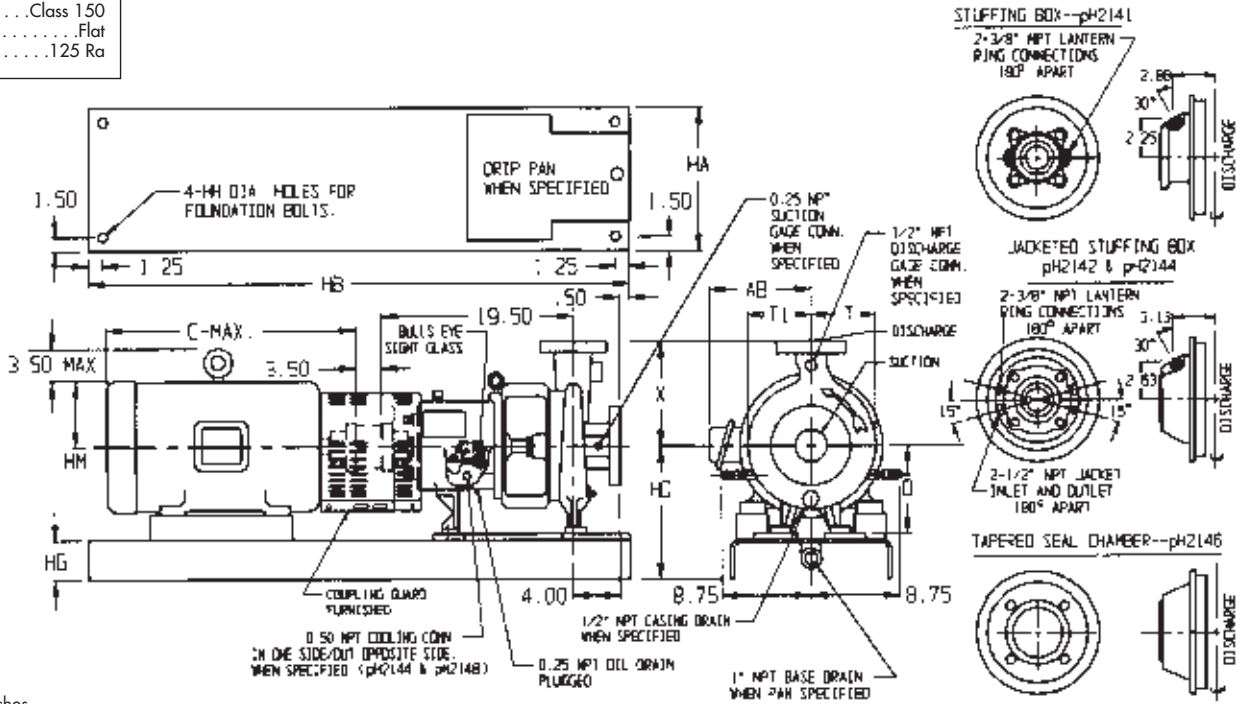

All dimensions in inches

ANSI SIZE	PUMP SIZE	DISCHARGE					SUCTION					D	X	T	T1
		SIZE	O.D.	THK	B.C.	BOLTS	SIZE	O.D.	THK	B.C.	BOLTS				
A05	1x2x8 1/2	1	4.25	.563	3.13	4-1/2	2	6	.750	4.75	4-5/8	8.25	8.50	5.75	5.75
A50	1 1/2x3x8 1/2	1.5	5	.688	3.88	4-1/2	3	7.50	.938	6	4-5/8	8.25	8.50	5.88	5.75
A60	2x3x8 1/2	2	6	.750	4.75	4-5/8	3	7.50	.938	6	4-5/8	8.25	9.50	6.25	5.75
A70	3x4x8 1/2 #1	3	7.50	.938	6	4-5/8	4	9	.938	7.50	8-5/8	8.25	11	7	6.13
A70	3x4x8 1/2 #2	3	7.50	.938	6	4-5/8	4	9	.938	7.50	8-5/8	8.25	11	7.63	6.38
A05	1x2x10	1	4.25	.563	3.13	4-1/2	2	6	.750	4.75	4-5/8	8.25	8.50	5.75	5.75
A50	1 1/2x3x10	1.5	5	.688	3.88	4-1/2	3	7.50	.938	6	4-5/8	8.25	8.50	6.25	6.25
A60	2x3x10	2	6	.750	4.75	4-5/8	3	7.50	.938	6	4-5/8	8.25	9.50	6.75	6.25
A70	3x4x10 #1	3	7.50	.938	6	4-5/8	4	9	.938	7.50	8-5/8	8.25	11	7.38	6.38
A70	3x4x10 #2	3	7.50	.938	6	4-5/8	4	9	.938	7.50	8-5/8	10	11.75	8.50	7.38
A20	1 1/2x3x11 1/2	1.5	5	.688	3.88	4-1/2	3	7.50	.938	6	4-5/8	10	10.50	7.63	7.13
A30	2x3x11 1/2	2	6	.750	4.75	4-5/8	3	7.50	.938	6	4-5/8	10	11.50	8.25	7.50
A40	3x4x11 1/2	3	7.50	.938	6	4-5/8	4	9	.938	7.50	8-5/8	10	12.50	9	8
A80	4x6x11 1/2	4	9	.938	7.50	8-5/8	6	11	1	9.50	8-3/4	10	13.50	9.75	8.25
A20	1 1/2x3x13 1/2	1.5	5	.688	3.88	4-1/2	3	7.50	.938	6	4-5/8	10	10.50	8.25	8.25
A30	2x3x13 1/2	2	6	.750	4.75	4-5/8	3	7.50	.938	6	4-5/8	10	11.50	8.75	8.25
A40	3x4x13 1/2	3	7.50	.938	6	4-5/8	4	9	.938	7.50	8-5/8	10	12.50	9.38	8.50

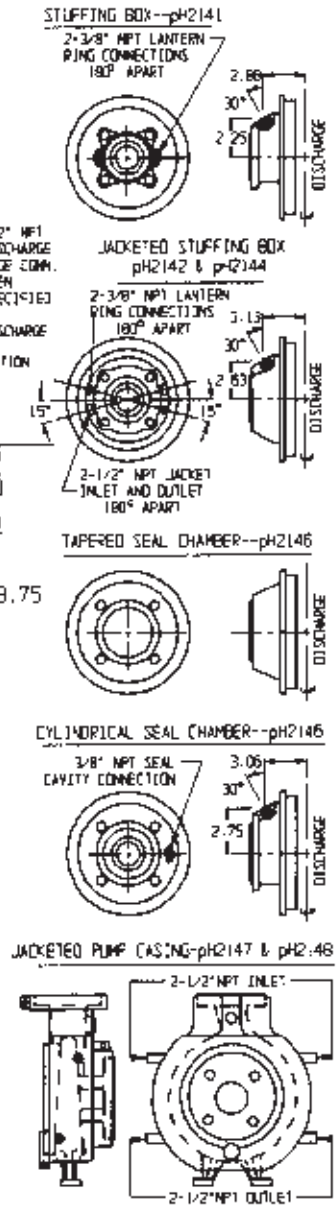

FRAME	C	AB	HA	HB	HD		HG	HH	HM
					D=8 1/4	D=10			
143T	13.25	6.50	12	45	12	13.75	3.75	.75	3.88
145T	13.75	6.50	12	45	12	13.75	3.75	.75	3.88
182T	14.63	7.50	12	45	12	13.75	3.75	.75	5.25
184T	15.63	7.50	12	45	12	13.75	3.75	.75	5.25
213T	18.13	9.50	12	45	12	13.75	3.75	.75	6
215T	19.63	9.50	12	45	12	13.75	3.75	.75	6
254T	23.13	11.00	15	52	12.38	14.13	4.13	.75	7
256T	24.88	11.00	15	52	12.38	14.13	4.13	.75	7
284T	26.88	12.63	15	52	12.38	14.13	4.13	.75	7.75
284TS	25.50	12.63	15	52	12.38	14.13	4.13	.75	7.75

FRAME	C	AB	HA	HB	HD		HG	HH	HM
					D=8 1/4	D=10			
286T	28.38	12.63	15	52	12.38	14.13	4.13	.75	7.75
286TS	27.00	12.63	15	52	12.38	14.13	4.13	.75	7.75
324T	29.88	14.75	18	58	13	14.75	4.75	1	8.75
324TS	28.38	14.75	18	58	13	14.75	4.75	1	8.75
326T	31.38	14.75	18	58	13	14.75	4.75	1	8.75
326TS	29.88	14.75	18	58	13	14.75	4.75	1	8.75
364T	33.13	16.25	18	58	13.88	14.75	4.75	1	9.88
364TS	31.50	16.25	18	58	13.88	14.75	4.75	1	9.88
365TS	32.50	16.25	18	58	13.88	14.75	4.75	1	9.88

IMPORTANT: Do not use for construction unless certified.

DIMENSION DWG.
NO. PH2243

**TYPE PH2140 SERIES
STANDARD, END SUCTION, OPEN IMPELLER, CENTRIFUGAL PROCESS PUMPS WITH "ANSI" BASEPLATE**

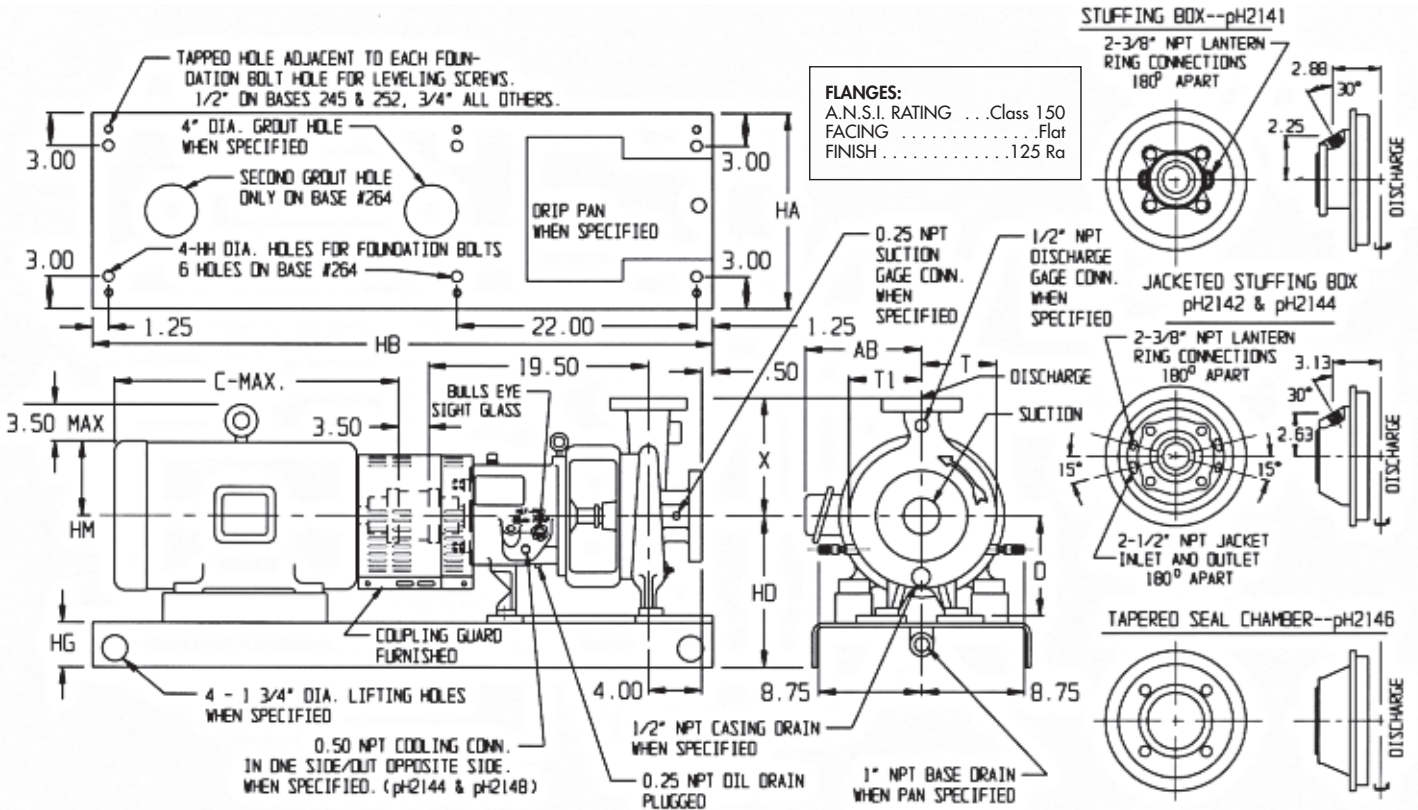

All dimensions in inches

ANSI SIZE	PUMP SIZE	DISCHARGE					SUCTION					D	X	T	T1
		SIZE	O.D.	THK	B.C.	BOLTS	SIZE	O.D.	THK	B.C.	BOLTS				
A05	1x2x8 1/2	1	4.25	.563	3.13	4-1/2	2	6	.750	4.75	4-5/8	8.25	8.50	5.75	5.75
A50	1 1/2x3x8 1/2	1.5	5	.688	3.88	4-1/2	3	7.50	.938	6	4-5/8	8.25	8.50	5.88	5.75
A60	2x3x8 1/2	2	6	.750	4.75	4-5/8	3	7.50	.938	6	4-5/8	8.25	9.50	6.25	5.75
A70	3x4x8 1/2 #1	3	7.50	.938	6	4-5/8	4	9	.938	7.50	8-5/8	8.25	11	7	6.13
	3x4x8 1/2 #2	3	7.50	.938	6	4-5/8	4	9	.938	7.50	8-5/8	8.25	11	7.63	6.38
A05	1x2x10	1	4.25	.563	3.13	4-1/2	2	6	.750	4.75	4-5/8	8.25	8.50	5.75	5.75
A50	1 1/2x3x10	1.5	5	.688	3.88	4-1/2	3	7.50	.938	6	4-5/8	8.25	8.50	6.25	6.25
A60	2x3x10	2	6	.750	4.75	4-5/8	3	7.50	.938	6	4-5/8	8.25	9.50	6.75	6.25
A70	3x4x10 #1	3	7.50	.938	6	4-5/8	4	9	.938	7.50	8-5/8	8.25	11	7.38	6.38
	3x4x10 #2	3	7.50	.938	6	4-5/8	4	9	.938	7.50	8-5/8	10	11.75	8.50	7.38
A20	1 1/2x3x11 1/2	1.5	5	.688	3.88	4-1/2	3	7.50	.938	6	4-5/8	10	10.50	7.63	7.13
A30	2x3x11 1/2	2	6	.750	4.75	4-5/8	3	7.50	.938	6	4-5/8	10	11.50	8.25	7.50
A40	3x4x11 1/2	3	7.50	.938	6	4-5/8	4	9	.938	7.50	8-5/8	10	12.50	9	8
A80	4x6x11 1/2	4	9	.938	7.50	8-5/8	6	11	1	9.50	8-3/4	10	13.50	9.75	8.25
A20	1 1/2x3x13 1/2	1.5	5	.688	3.88	4-1/2	3	7.50	.938	6	4-5/8	10	10.50	8.25	8.25
A30	2x3x13 1/2	2	6	.750	4.75	4-5/8	3	7.50	.938	6	4-5/8	10	11.50	8.75	8.25
A40	3x4x13 1/2	3	7.50	.938	6	4-5/8	4	9	.938	7.50	8-5/8	10	12.50	9.38	8.50

FRAME	ANSI BASE #	C	AB	HA	HB	HD		HG	HH	HM
						D=8 1/4	D=10			
143T	245	13.25	6.50	15	45	12	13.75	3.75	.75	3.88
145T		13.75	6.50	15	45	12	13.75	3.75	.75	3.88
182T		14.63	7.50	15	45	12	13.75	3.75	.75	5.25
184T		15.63	7.50	15	45	12	13.75	3.75	.75	5.25
213T	252	18.13	9.50	18	52	12.38	14.13	4.13	.75	6
215T		19.63	9.50	18	52	12.38	14.13	4.13	.75	6
254T	258	23.13	10.75	21	58	13.00	14.75	4.75	1	7
256T		24.88	10.75	21	58	13.00	14.75	4.75	1	7
284T		26.88	12.63	21	58	13.00	14.75	4.75	1	7.75
284TS		25.50	12.63	21	58	13.00	14.75	4.75	1	7.75

FRAME	ANSI BASE #	C	AB	HA	HB	HD		HG	HH	HM
						D=8 1/4	D=10			
286T	258	28.38	12.63	21	58	13.00	14.75	4.75	1	7.75
286TS		27.00	12.63	21	58	13.00	14.75	4.75	1	7.75
324T		29.88	14.75	21	64	13.88	14.75	4.75	1	8.75
324TS		28.38	14.75	21	64	13.88	14.75	4.75	1	8.75
326T	264	31.38	14.75	21	64	13.88	14.75	4.75	1	8.75
326TS		29.88	14.75	21	64	13.88	14.75	4.75	1	8.75
364T		33.13	16.25	21	64	13.88	14.75	4.75	1	9.88
364TS		31.50	16.25	21	64	13.88	14.75	4.75	1	9.88
365TS	268	32.50	16.25	21	64	13.88	14.75	4.75	1	9.88
405TS		35.50	20.25	26	68	14.88	14.88	4.75	1	11.00

IMPORTANT: Do not use for construction unless certified.

TYPE PH2140 SERIES
STANDARD, END SUCTION, OPEN IMPELLER, CENTRIFUGAL PROCESS PUMPS WITH "C" FLANGE ADAPTOR
FOR MOTOR FRAMES: 143TC, 145TC, 182TC, 184TC, 213TC, & 215TC

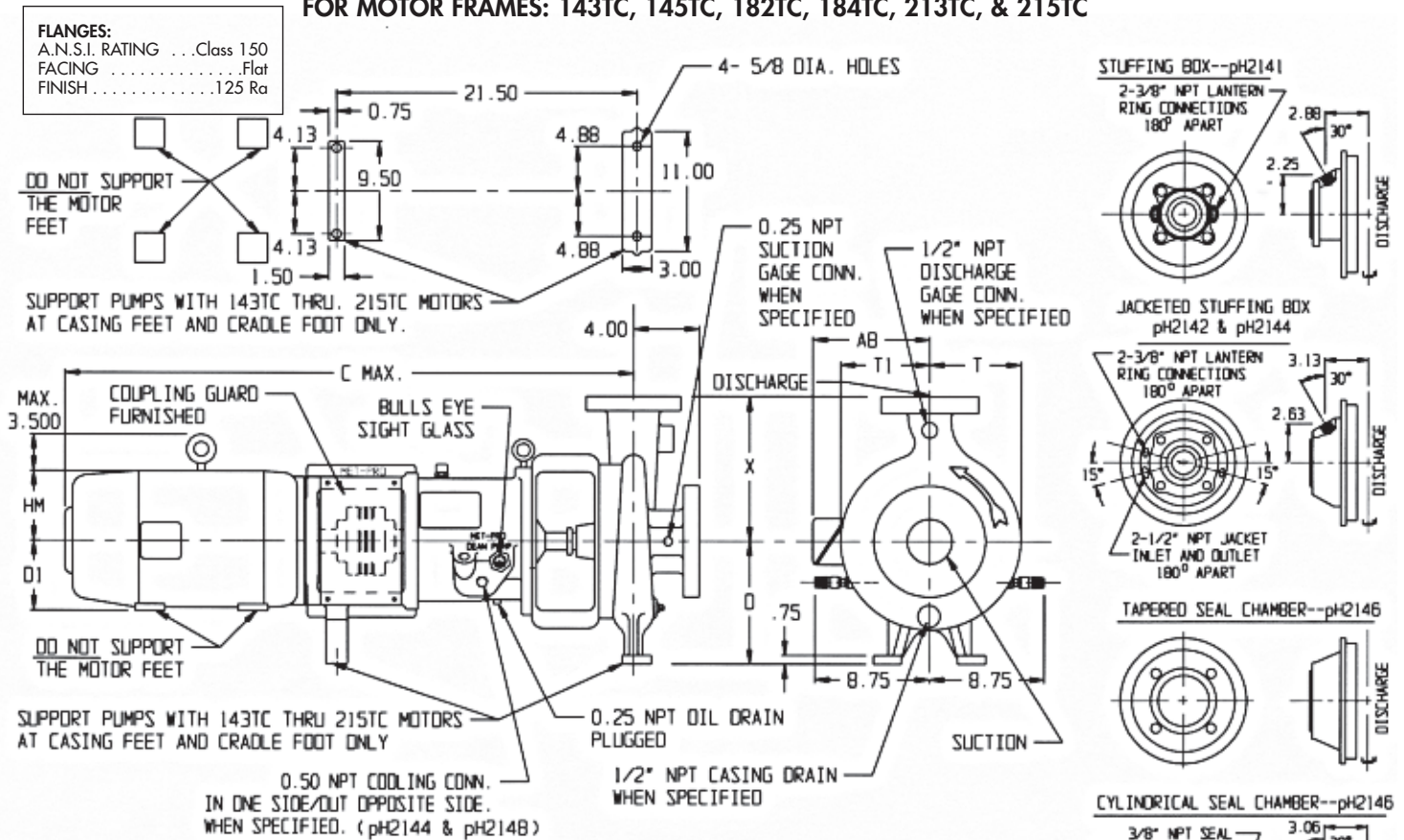

All dimensions in inches

ANSI SIZE	PUMP SIZE	DISCHARGE					SUCTION					D	X	T	T1
		SIZE	O.D.	THK	B.C.	BOLTS	SIZE	O.D.	THK	B.C.	BOLTS				
A05	1x2x8 1/2	1	4.25	.563	3.13	4-1/2	2	6	.750	4.75	4-5/8	8.25	8.50	5.75	5.75
A50	1 1/2x3x8 1/2	1.5	5	.688	3.88	4-1/2	3	7.50	.938	6	4-5/8	8.25	8.50	5.88	5.75
A60	2x3x8 1/2	2	6	.750	4.75	4-5/8	3	7.50	.938	6	4-5/8	8.25	9.50	6.25	5.75
A70	3x4x8 1/2 #1	3	7.50	.938	6	4-5/8	4	9	.938	7.50	8-5/8	8.25	11	7	6.13
	3x4x8 1/2 #2	3	7.50	.938	6	4-5/8	4	9	.938	7.50	8-5/8	8.25	11	7.63	6.38
A05	1x2x10	1	4.25	.563	3.13	4-1/2	2	6	.750	4.75	4-5/8	8.25	8.50	5.75	5.75
A50	1 1/2x3x10	1.5	5	.688	3.88	4-1/2	3	7.50	.938	6	4-5/8	8.25	8.50	6.25	6.25
A60	2x3x10	2	6	.750	4.75	4-5/8	3	7.50	.938	6	4-5/8	8.25	9.50	6.75	6.25
A70	3x4x10 #1	3	7.50	.938	6	4-5/8	4	9	.938	7.50	8-5/8	8.25	11	7.38	6.38
	3x4x10 #2	3	7.50	.938	6	4-5/8	4	9	.938	7.50	8-5/8	10	11.75	8.50	7.38
A20	1 1/2x3x11 1/2	1.5	5	.688	3.88	4-1/2	3	7.50	.938	6	4-5/8	10	10.50	7.63	7.13
A30	2x3x11 1/2	2	6	.750	4.75	4-5/8	3	7.50	.938	6	4-5/8	10	11.50	8.25	7.50
A40	3x4x11 1/2	3	7.50	.938	6	4-5/8	4	9	.938	7.50	8-5/8	10	12.50	9	8
A80	4x6x11 1/2	4	9	.938	7.50	8-5/8	6	11	1	9.50	8-3/4	10	13.50	9.75	8.25
A20	1 1/2x3x13 1/2	1.5	5	.688	3.88	4-1/2	3	7.50	.938	6	4-5/8	10	10.50	8.25	8.25
A30	2x3x13 1/2	2	6	.750	4.75	4-5/8	3	7.50	.938	6	4-5/8	10	11.50	8.75	8.25
A40	3x4x13 1/2	3	7.50	.938	6	4-5/8	4	9	.938	7.50	8-5/8	10	12.50	9.38	8.50

FRAME	C	D1	AB	HM
143TC	38.50	3.50	6.50	3.88
145TC	38.50	3.50	6.50	3.88
182TC	41.00	4.50	7.50	5.25
184TC	42.50	4.50	7.50	5.25
213TC	43.00	5.25	9.50	6.00
215TC	43.00	5.25	9.50	6.00

IMPORTANT: Do not use for construction unless certified.

DIMENSION DWG.
NO. PH2239

14

TYPE PH2140 SERIES STANDARD, END SUCTION, OPEN IMPELLER, CENTRIFUGAL PROCESS PUMPS WITH "C" FLANGE ADAPTOR FOR MOTOR FRAMES: 254TC THRU 365TSC

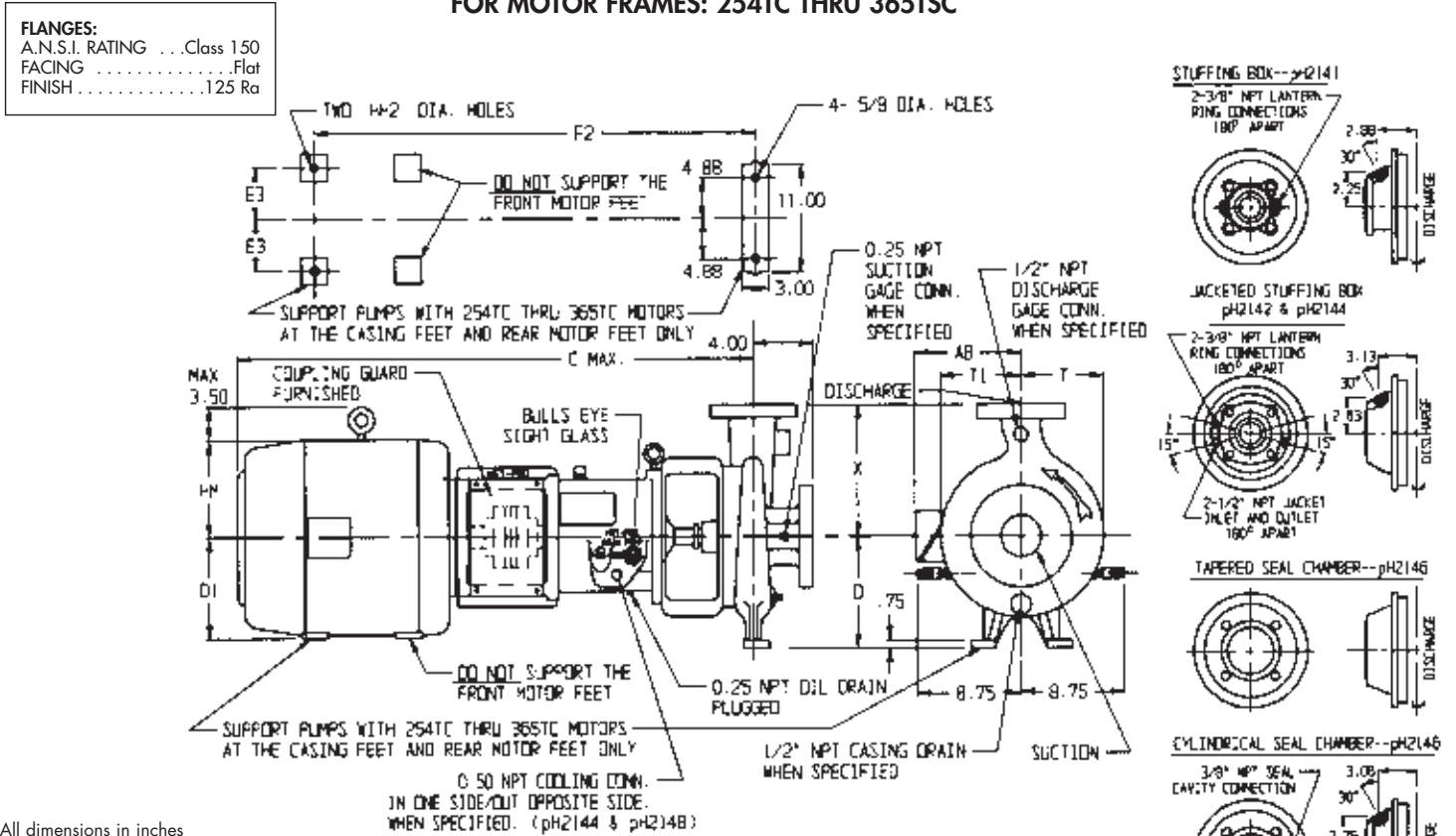

14

ANSI SIZE	PUMP SIZE	DISCHARGE					SUCTION					D	X	T	T1
		SIZE	O.D.	THK	B.C.	BOLTS	SIZE	O.D.	THK	B.C.	BOLTS				
A05	1x2x8½	1	4.25	.563	3.13	4-1/2	2	6	.750	4.75	4-5/8	8.25	8.50	5.75	5.75
A50	1½x3x8½	1.5	5	.688	3.88	4-1/2	3	7.50	.938	6	4-5/8	8.25	8.50	5.88	5.75
A60	2x3x8½	2	6	.750	4.75	4-5/8	3	7.50	.938	6	4-5/8	8.25	9.50	6.25	5.75
A70	3x4x8½ #1	3	7.50	.938	6	4-5/8	4	9	.938	7.50	8-5/8	8.25	11	7	6.13
	3x4x8½ #2	3	7.50	.938	6	4-5/8	4	9	.938	7.50	8-5/8	8.25	11	7.63	6.38
A05	1x2x10	1	4.25	.563	3.13	4-1/2	2	6	.750	4.75	4-5/8	8.25	8.50	5.75	5.75
A50	1½x3x10	1.5	5	.688	3.88	4-1/2	3	7.50	.938	6	4-5/8	8.25	8.50	6.25	6.25
A60	2x3x10	2	6	.750	4.75	4-5/8	3	7.50	.938	6	4-5/8	8.25	9.50	6.75	6.25
A70	3x4x10 #1	3	7.50	.938	6	4-5/8	4	9	.938	7.50	8-5/8	8.25	11	7.38	6.38
	3x4x10 #2	3	7.50	.938	6	4-5/8	4	9	.938	7.50	8-5/8	10	11.75	8.50	7.38
A20	1½x3x11½	1.5	5	.688	3.88	4-1/2	3	7.50	.938	6	4-5/8	10	10.50	7.63	7.13
A30	2x3x11½	2	6	.750	4.75	4-5/8	3	7.50	.938	6	4-5/8	10	11.50	8.25	7.50
A40	3x4x11½	3	7.50	.938	6	4-5/8	4	9	.938	7.50	8-5/8	10	12.50	9	8
A80	4x6x11½	4	9	.938	7.50	8-5/8	6	11	1	9.50	8-3/4	10	13.50	9.75	8.25
A20	1½x3x13½	1.5	5	.688	3.88	4-1/2	3	7.50	.938	6	4-5/8	10	10.50	8.25	8.25
A30	2x3x13½	2	6	.750	4.75	4-5/8	3	7.50	.938	6	4-5/8	10	11.50	8.75	8.25
A40	3x4x13½	3	7.50	.938	6	4-5/8	4	9	.938	7.50	8-5/8	10	12.50	9.38	8.50

FRAME	C	D1	E3	F2	AB	HH2	HM
254TC	45.00	6.25	5.00	36.50	11.00	.531	7.00
256TC	47.00	6.25	5.00	38.25	11.00	.531	7.00
284TSC	48.00	7.00	5.50	37.38	12.63	.531	7.75
286TSC	50.00	7.00	5.50	38.88	12.63	.531	7.75
324TSC	50.00	8.00	6.25	39.00	14.75	.656	8.75
326TSC	52.00	8.00	6.25	40.50	14.75	.656	8.75
364TSC	52.00	9.00	7.00	39.38	16.25	.656	9.88
365TSC	54.00	9.00	7.00	41.38	16.25	.656	9.88

IMPORTANT: Do not use for construction unless certified.

**DIMENSION DWG.
NO. PH2241**

16

**TYPE PH2140 SERIES
STANDARD, END SUCTION, OPEN IMPELLER, CENTRIFUGAL PROCESS PUMPS
WITH "ECONOMY" BASEPLATE AND "C" FLANGE ADAPTOR**

FLANGES:
A.N.S.I. RATING Class 150
FACING Flat
FINISH 125 Ra

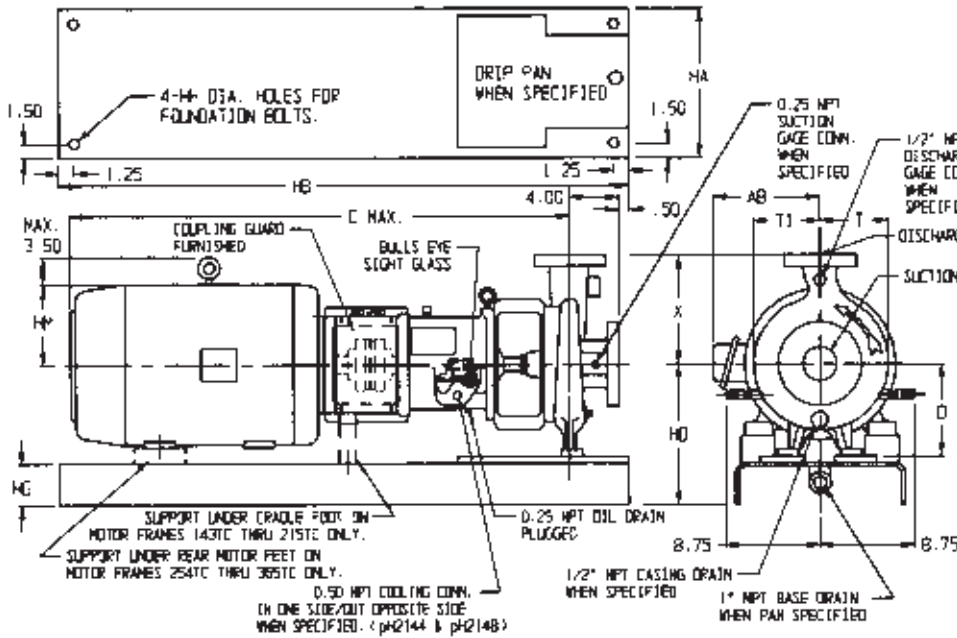

All dimensions in inches

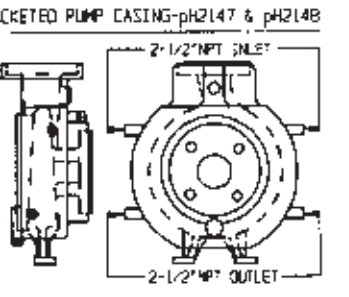
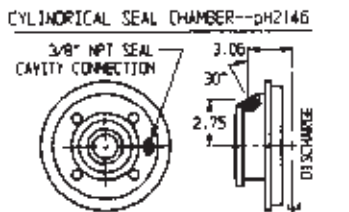
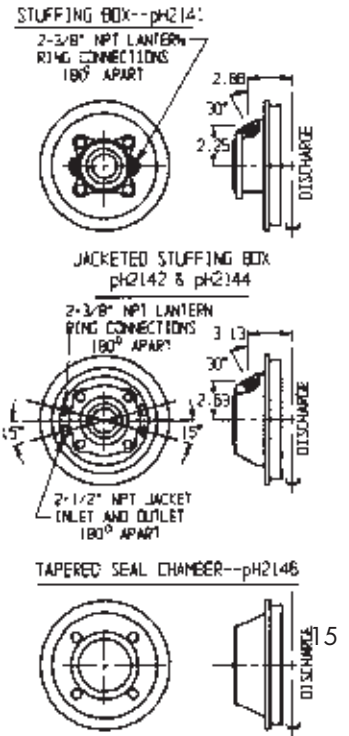

ANSI SIZE	PUMP SIZE	DISCHARGE					SUCTION					D	X	T	T1
		SIZE	O.D.	THK	B.C.	BOLTS	SIZE	O.D.	THK	B.C.	BOLTS				
A05	1x2x8 1/2	1	4.25	.563	3.13	4-1/2	2	6	.750	4.75	4-5/8	8.25	8.50	5.75	5.75
A50	1 1/2x3x8 1/2	1.5	5	.688	3.88	4-1/2	3	7.50	.938	6	4-5/8	8.25	8.50	5.88	5.75
A60	2x3x8 1/2	2	6	.750	4.75	4-5/8	3	7.50	.938	6	4-5/8	8.25	9.50	6.25	5.75
A70	3x4x8 1/2 #1	3	7.50	.938	6	4-5/8	4	9	.938	7.50	8-5/8	8.25	11	7	6.13
	3x4x8 1/2 #2	3	7.50	.938	6	4-5/8	4	9	.938	7.50	8-5/8	8.25	11	7.63	6.38
A05	1x2x10	1	4.25	.563	3.13	4-1/2	2	6	.750	4.75	4-5/8	8.25	8.50	5.75	5.75
A50	1 1/2x3x10	1.5	5	.688	3.88	4-1/2	3	7.50	.938	6	4-5/8	8.25	8.50	6.25	6.25
A60	2x3x10	2	6	.750	4.75	4-5/8	3	7.50	.938	6	4-5/8	8.25	9.50	6.75	6.25
A70	3x4x10 #1	3	7.50	.938	6	4-5/8	4	9	.938	7.50	8-5/8	8.25	11	7.38	6.38
	3x4x10 #2	3	7.50	.938	6	4-5/8	4	9	.938	7.50	8-5/8	10	11.75	8.50	7.38
A20	1 1/2x3x11 1/2	1.5	5	.688	3.88	4-1/2	3	7.50	.938	6	4-5/8	10	10.50	7.63	7.13
A30	2x3x11 1/2	2	6	.750	4.75	4-5/8	3	7.50	.938	6	4-5/8	10	11.50	8.25	7.50
A40	3x4x11 1/2	3	7.50	.938	6	4-5/8	4	9	.938	7.50	8-5/8	10	12.50	9	8
A80	4x6x11 1/2	4	9	.938	7.50	8-5/8	6	11	1	9.50	8-3/4	10	13.50	9.75	8.25
A20	1 1/2x3x13 1/2	1.5	5	.688	3.88	4-1/2	3	7.50	.938	6	4-5/8	10	10.50	8.25	8.25
A30	2x3x13 1/2	2	6	.750	4.75	4-5/8	3	7.50	.938	6	4-5/8	10	11.50	8.75	8.25
A40	3x4x13 1/2	3	7.50	.938	6	4-5/8	4	9	.938	7.50	8-5/8	10	12.50	9.38	8.50

FRAME	C	AB	HA	HB	HD		HG	HH	HM
					D=8 1/4	D=10			
143TC	38.50	6.50	12	45	12	13.75	3.75	.75	3.88
145TC	38.50	6.50	12	45	12	13.75	3.75	.75	3.88
182TC	41.00	7.50	12	45	12	13.75	3.75	.75	5.25
184TC	42.50	7.50	12	45	12	13.75	3.75	.75	5.25
213TC	43.00	9.50	12	45	12.75	13.75	3.75	.75	6
215TC	43.00	9.50	12	45	12.75	13.75	3.75	.75	6
254TC	45.00	11.00	15	52	12.38	14.13	4.13	.75	7

FRAME	C	AB	HA	HB	HD		HG	HH	HM
					D=8 1/4	D=10			
256TC	47.00	11.00	15	52	12.38	14.13	4.13	.75	7
284TSC	48.00	12.63	15	52	13.13	14.88	4.13	.75	7.75
286TSC	50.00	12.63	15	52	13.13	14.88	4.13	.75	7.75
324TSC	50.00	14.75	18	58	13.00	15.50	4.75	1	8.75
326TSC	52.00	14.75	18	58	13.00	15.50	4.75	1	8.75
364TSC	52.00	16.25	18	58	14.00	14.75	4.75	1	9.88
365TSC	54.00	16.25	18	58	14.00	14.75	4.75	1	9.88

IMPORTANT: Do not use for construction unless certified.

**DIMENSION DWG.
NO. PH2242**

TYPE PH3170* SERIES
STANDARD, END SUCTION, OPEN IMPELLER, CENTRIFUGAL PROCESS PUMPS

FLANGES:
 A.N.S.I. RATINGSee Table
 FACINGFlat
 FINISH125 Ra

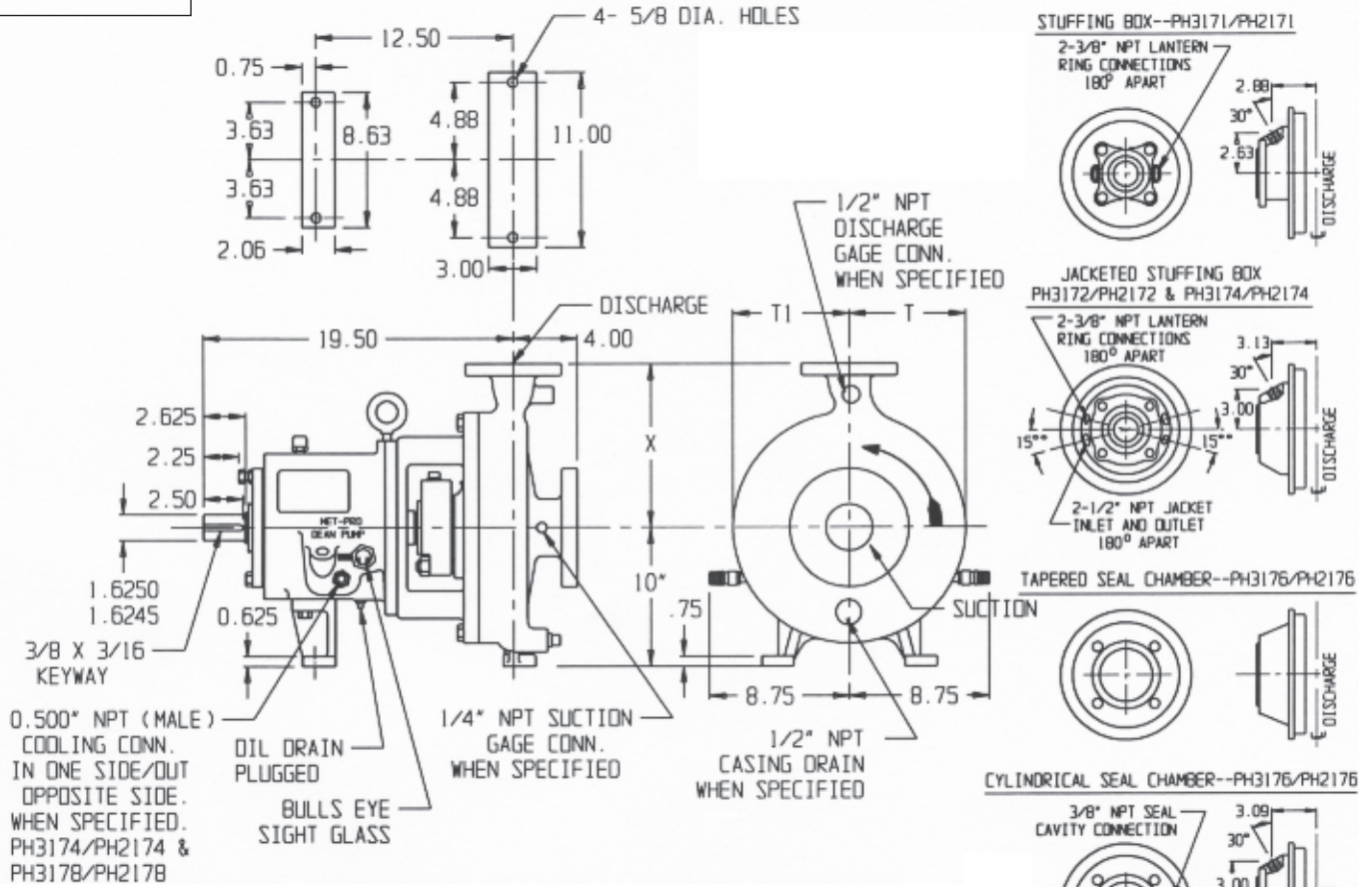

NOTE: The flanges have through holes for the bolting, except for the suction flange of the 4x6x13-1/2 pump which has studs in tapped holes.

All dimensions in inches

ANSI Size	PUMP SIZE	ANSI FLANGE CLASS	DISCHARGE					SUCTION					X	T	T1
			SIZE	O.D.	THK	B.C.	BOLTS	SIZE	O.D.	THK	B.C.	BOLTS			
A20	1 1/2x3x13 1/2	300	1.5	6.13	.813	4.50	4-3/4	3	8.25	1.13	6.63	8-3/4	10.50	8.31	8.31
A30	2x3x13 1/2	300	2	6.50	.875	5.00	8-5/8	3	8.25	1.13	6.63	8-3/4	11.50	8.88	8.38
A40	3x4x13 1/2	300	3	8.25	1.13	6.63	8-3/4	4	10	1.25	7.88	8-3/4	12.50	9.50	8.63
A80*	4x6x13 1/2	150	4	9	.938	7.50	8-5/8	6	11	1	9.50	8-3/4	13.50	10.38	9.25

* The Size A80 pump is a Type pH2170

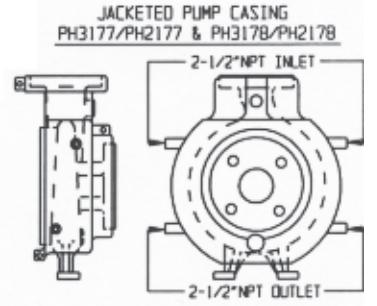

TYPE PH3170[®] SERIES
STANDARD, END SUCTION, OPEN IMPELLER, CENTRIFUGAL PROCESS PUMPS
WITH "ECONOMY" BASEPLATE

FLANGES:
 A.N.S.I. RATINGSee Table
 FACINGFlat
 FINISH125 Ra

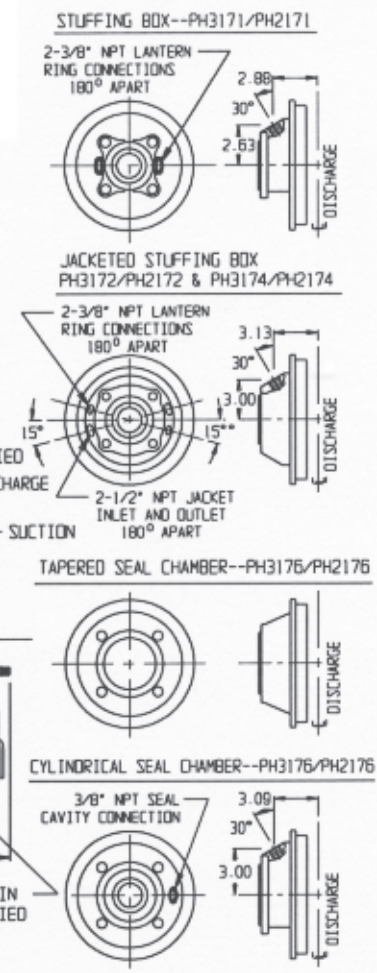
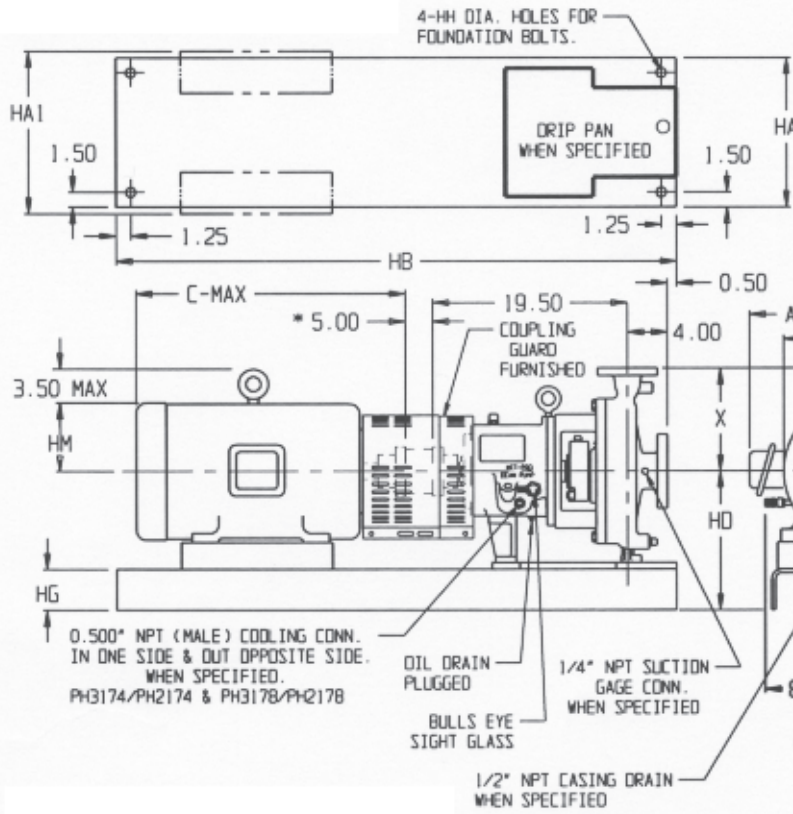

NOTE: The flanges have through holes for the bolting, except for the suction flange of the 4x6x13-1/2 pump which has studs in tapped holes.

All dimensions in inches

ANSI SIZE	PUMP SIZE	ANSI FLANGE CLASS	DISCHARGE					SUCTION					X
			SIZE	O.D.	THK	B.C.	BOLTS	SIZE	O.D.	THK	B.C.	BOLTS	
A20	1 1/2x3x13 1/2	300	1.5	6.13	.813	4.50	4-3/4	3	8.25	1.13	6.63	8-3/4	10.50
A30	2x3x13 1/2	300	2	6.50	.875	5.00	8-5/8	3	8.25	1.13	6.63	8-3/4	11.50
A40	3x4x13 1/2	300	3	8.25	1.13	6.63	8-3/4	4	10	1.25	7.88	8-3/4	12.50
A80 [‡]	4x6x13 1/2	150	4	9	.938	7.50	8-5/8	6	11	1	9.50	8-3/4	13.50

[‡] The Size A80 pump is a Type pH2170
 * For horse power below 40 @ 1750 and 100 @ 3500 rpm spacer is 3.50

FRAME	C	AB	HA	HB	HD	HG	HH	HM	HA1
254T	23.13	11	15	52	14.13	4.13	.75	7	—
256T	24.88	11	15	52	14.13	4.13	.75	7	—
284T	26.88	12.63	15	52	14.13	4.13	.75	7.75	—
284TS	25.50	12.63	15	52	14.13	4.13	.75	7.75	—
286T	28.38	12.63	15	52	14.13	4.13	.75	7.75	—
286TS	27.00	12.63	15	52	14.13	4.13	.75	7.75	—
324T	29.88	14.75	18	58	14.75	4.75	1	8.75	—
324TS	28.38	14.75	18	58	14.75	4.75	1	8.75	—
326T	31.38	14.75	18	58	14.75	4.75	1	8.75	—
326TS	29.88	14.75	18	58	14.75	4.75	1	8.75	—
364TS	31.50	16.25	18	58	14.75	4.75	1	9.88	—
365TS	32.50	16.25	18	58	14.75	4.75	1	9.88	—
404TS	33.50	20.25	18	60	14.75	4.75	1	10.75	20
405TS	35.50	20.25	18	60	14.75	4.75	1	10.75	20
444TS	38.50	21.50	18	62	16.75	4.75	1	12.25	22
445TS	40.50	21.50	18	62	16.75	4.75	1	12.25	22

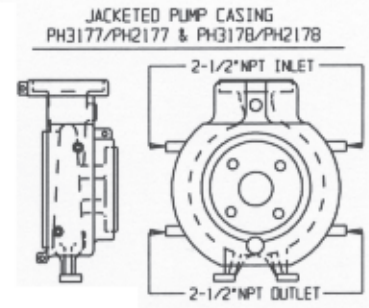

IMPORTANT: Do not use for construction unless certified.

DIMENSION DWG.
NO. PH2443

**TYPE PH3170* SERIES
STANDARD, END SUCTION, OPEN IMPELLER, CENTRIFUGAL PROCESS PUMPS
WITH "ANSI" BASEPLATE**

FLANGES:
A.N.S.I. RATINGSee Table
FACINGFlat
FINISH125 Ra

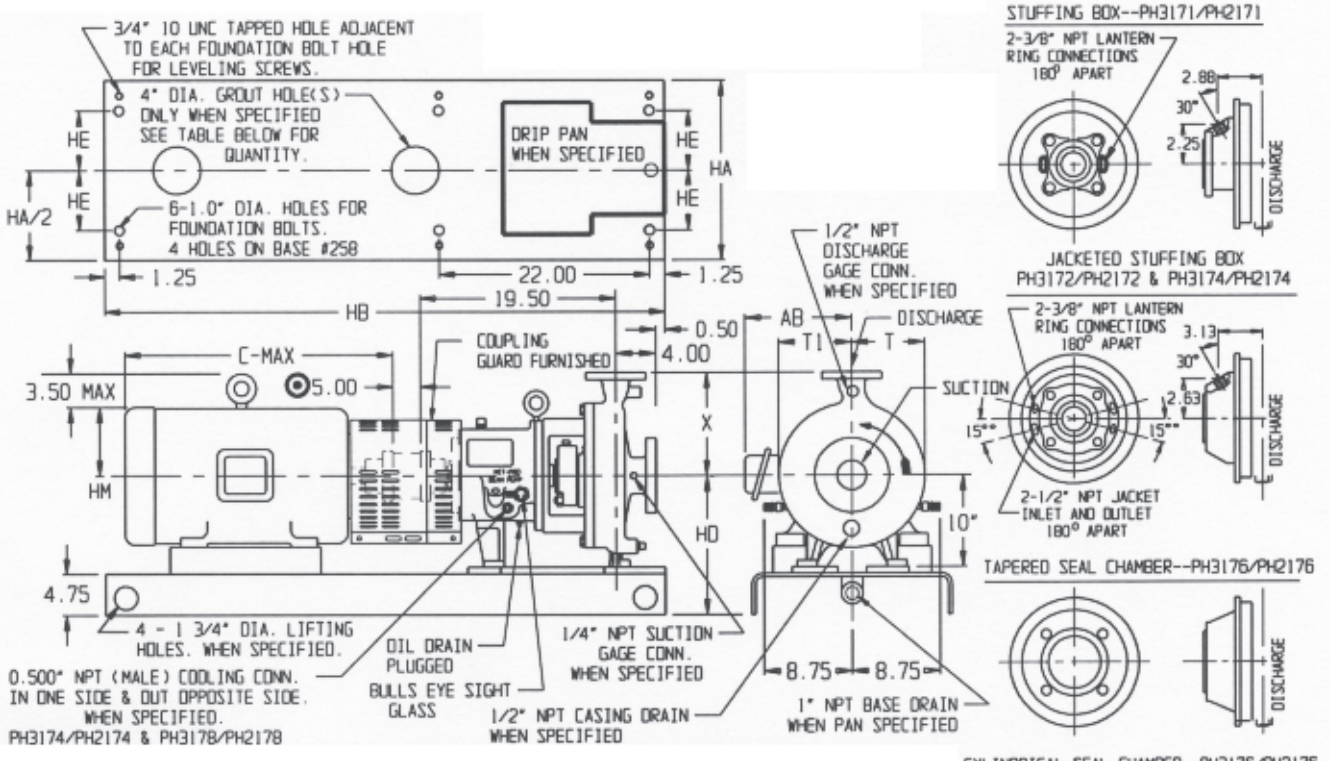

All dimensions in inches

ANSI SIZE	PUMP SIZE	ANSI FLANGE CLASS	DISCHARGE					SUCTION					X
			SIZE	O.D.	THK	B.C.	BOLTS	SIZE	O.D.	THK	B.C.	BOLTS	
A20	1½x3x13½	300	1.5	6.13	.813	4.50	4-¾	3	8.25	1.13	6.63	8-¾	10.50
A30	2x3x13½	300	2	6.50	.875	5.00	8-⅝	3	8.25	1.13	6.63	8-¾	11.50
A40	3x4x13½	300	3	8.25	1.13	6.63	8-¾	4	10	1.25	7.88	8-¾	12.50
A80*	4x6x13½	150	4	9	.938	7.50	8-⅝	6	11	1	9.50	8-¾	13.50

*The Size A80 pump is a Type pH2170

• For horsepower below 40 @ 1750 RPM and 100 @ 3500 RPM, the coupling spacer is 3.5" long

FRAME	ANSI BASE #	C	AB	HA	HB	HD	HE	HM	QT'Y OF GROUT HOLES
254T	258	23.13	11.00	21	58	14.75	7.50	7	1
256T		24.88	11.00	21	58	14.75	7.50	7	1
284T		26.88	12.63	21	58	14.75	7.50	7.75	1
284TS		25.50	12.63	21	58	14.75	7.50	7.75	1
286T		28.38	12.63	21	58	14.75	7.50	7.75	1
286TS		27.00	12.63	21	58	14.75	7.50	7.75	1
324T	264	29.88	14.75	21	64	14.75	7.50	8.75	2
324TS		28.38	14.75	21	64	14.75	7.50	8.75	2
326T		31.38	14.75	21	64	14.75	7.50	8.75	2
326TS		29.88	14.75	21	64	14.75	7.50	8.75	2
364TS		31.50	16.25	21	64	14.75	7.50	9.88	2
365TS		32.50	16.25	21	64	14.75	7.50	9.88	2
404TS	268	33.50	20.25	26	68	14.88	9.50	8.75	2
405TS		35.50	20.25	26	68	14.88	9.50	8.75	2
444TS	280	38.50	21.50	26	80	15.88	9.50	9.88	3
445TS		40.50	21.50	26	80	15.88	9.50	9.88	3

IMPORTANT: Do not use for construction unless certified.

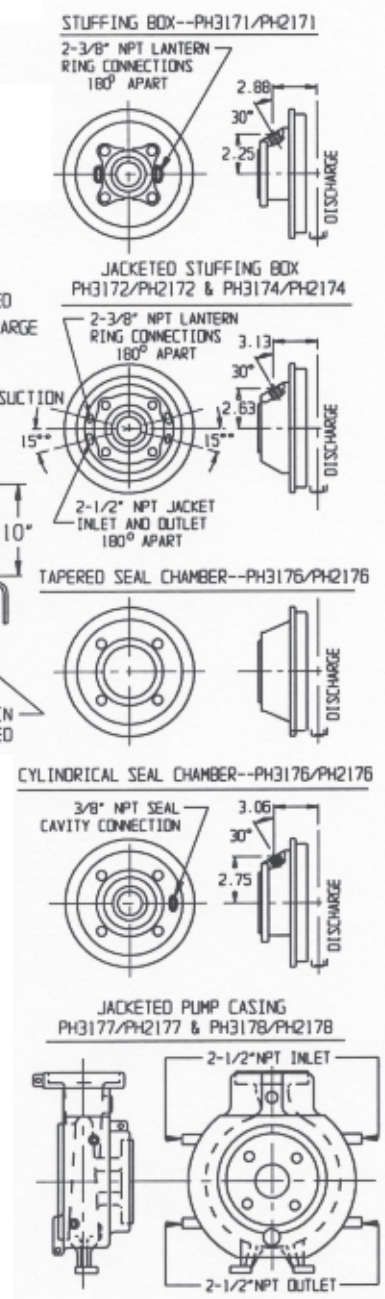

NOTE: The flanges have through holes for the bolting, except for the suction flange of the 4x6x13-1/2 pump which has studs in tapped holes.

**DIMENSION DWG.
NO. PH2445**

TYPE PH2180 SERIES
STANDARD, END SUCTION, OPEN IMPELLER, CENTRIFUGAL PROCESS PUMPS

FLANGES:
A.N.S.I. RATING300
FACINGFlat
FINISH125 Ra

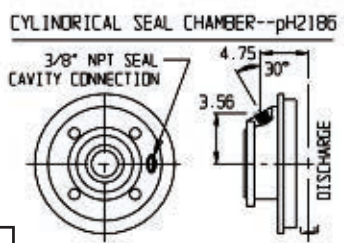
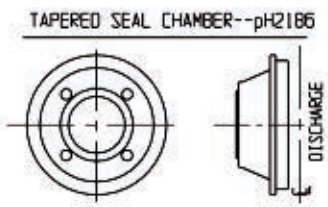
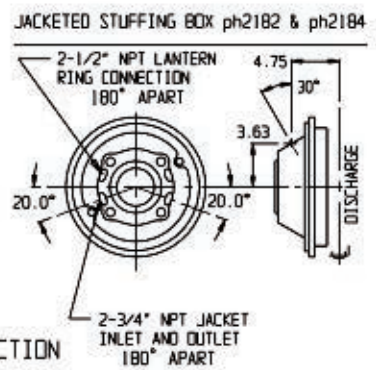
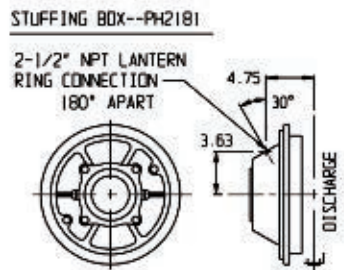
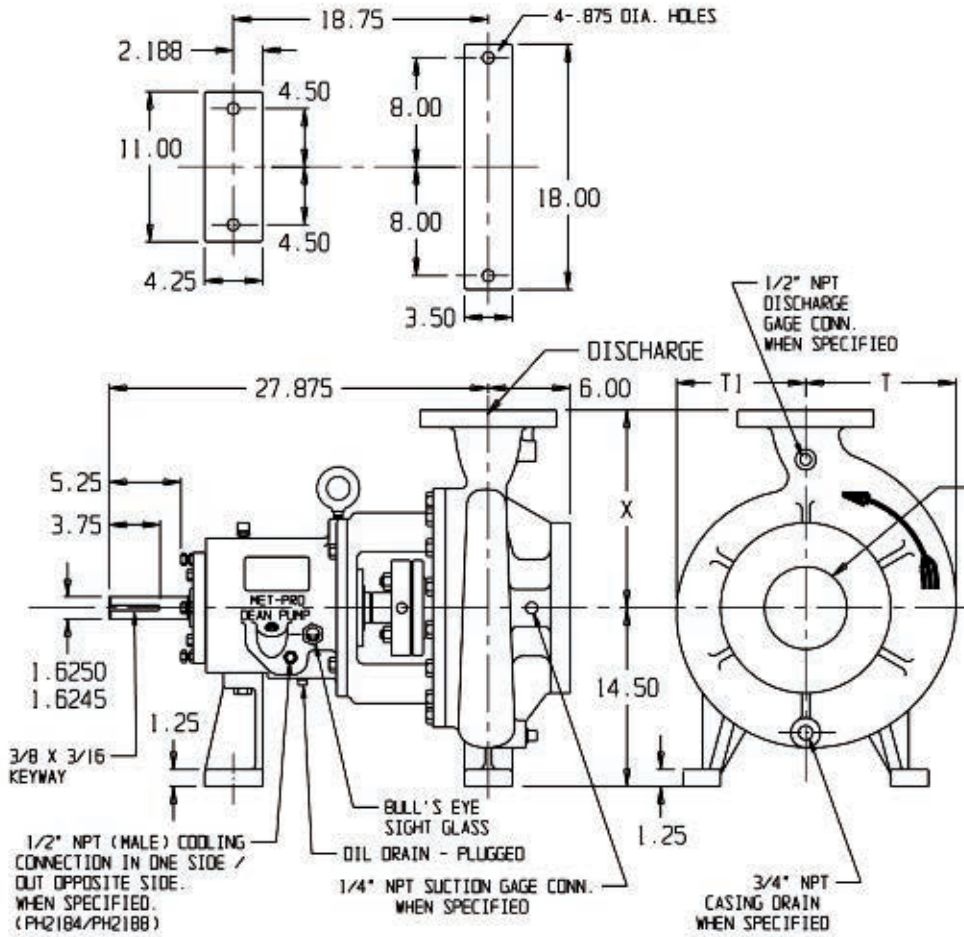

JACKETED PUMP CASING
ph2187 & ph2188

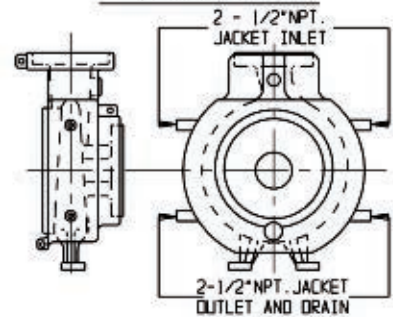

All dimensions in inches

PUMP SIZE	DISCHARGE					SUCTION					X	T	T1
	SIZE	O.D.	THK	B.C.	BOLTS	SIZE	O.D.	THK	B.C.	BOLTS			
4x6x13 1/2	4	10	1.25	7.88	8-3/4	6	12.50	1.44	10.63	12-3/4	14.50	11	9.50
6x8x13 1/2	6	12.5	1.44	10.63	12-3/4	8	15	1.63	13	12-7/8	16.50	13.75	10.50

IMPORTANT: Do not use for construction unless certified.

DIMENSION DWG.
NO. PH2545

TYPE PH2180 SERIES
STANDARD, END SUCTION, OPEN IMPELLER, CENTRIFUGAL PROCESS PUMPS
WITH "ECONOMY" BASEPLATE

FLANGES:
 A.N.S.I. RATING300
 FACINGFlat
 FINISH125 Ra

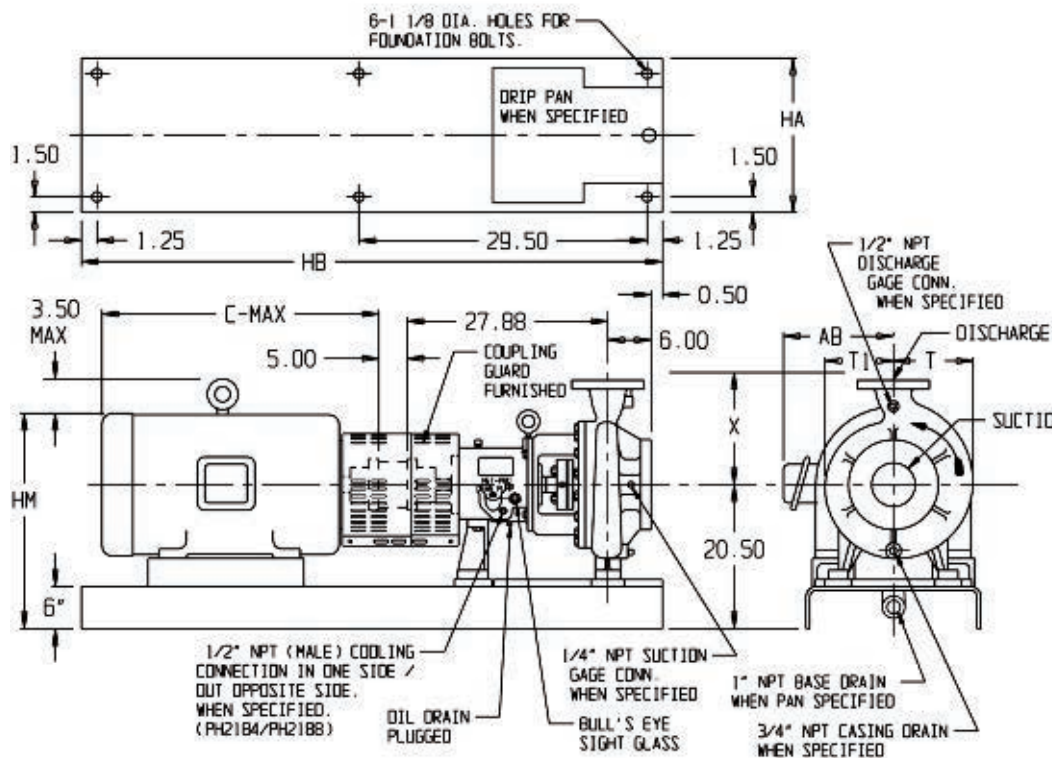

STUFFING BOX--pH2181

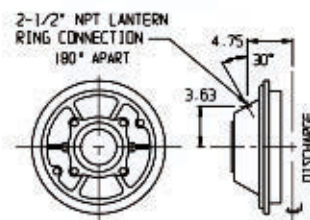

JACKETED STUFFING BOX pH2182 & pH2184

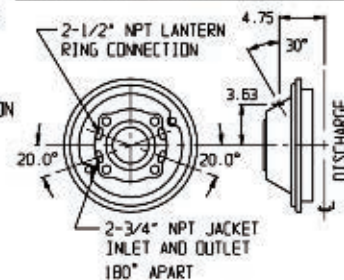

TAPERED SEAL CHAMBER--pH2186

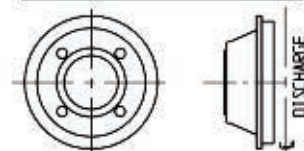

CYLINDRICAL SEAL CHAMBER--pH2186

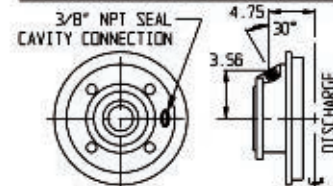

JACKETED PUMP CASING--pH2187 & pH2188

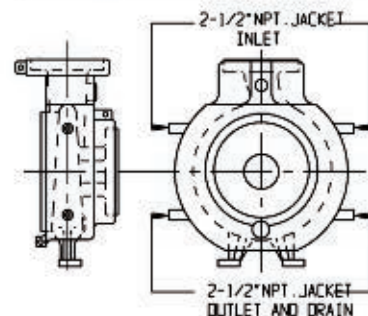

All dimensions in inches

PUMP SIZE	DISCHARGE					SUCTION					X	T	T1
	SIZE	O.D.	THK	B.C.	BOLTS	SIZE	O.D.	THK	B.C.	BOLTS			
4x6x13 1/2	4	10	1.25	7.88	8-3/4	6	12.50	1.44	10.63	12-3/4	14.50	11	9.50
6x8x13 1/2	6	12.5	1.44	10.63	12-3/4	8	15	1.63	13	12-7/8	16.50	13.50	10.50

FRAME	C	AB	HA	HB	HM
254T	23.13	11	20	68	27.25
256T	24.88	11	20	68	27.25
284T	26.88	12.63	20	68	28
286T	28.38	12.63	20	68	28
324TS	28.38	14.75	20	68	29
324T	29.88	14.75	20	68	29
326TS	29.88	14.75	20	68	29
326T	31.38	14.75	20	68	29
364TS	31.50	16.25	20	68	30.25

FRAME	C	AB	HA	HB	HM
364T	33.13	16.25	20	68	30.25
365TS	32.50	16.25	20	68	30.25
365T	33.88	16.25	20	68	30.25
404TS	33.50	20.25	22	80	31.25
404T	36.50	20.25	22	80	31.25
405TS	35.50	20.25	22	80	31.25
405T	38	20.25	22	80	31.25
444TS	38.50	21.50	22	80	32.75
445TS	40.50	21.50	22	80	32.75

IMPORTANT: Do not use for construction unless certified.

DIMENSION DWG.
NO. PH2643

TYPE PH2180 SERIES
STANDARD, END SUCTION, OPEN IMPELLER, CENTRIFUGAL PROCESS PUMPS
WITH "ANSI" BASEPLATE

FLANGES:
A.N.S.I. RATINGClass 300
FACINGFlat
FINISH125 Ra

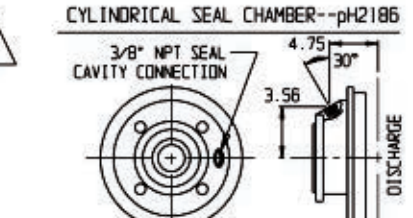
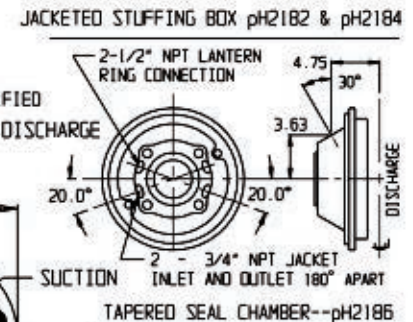
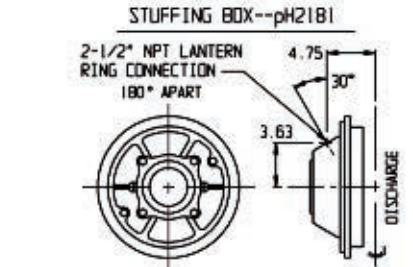
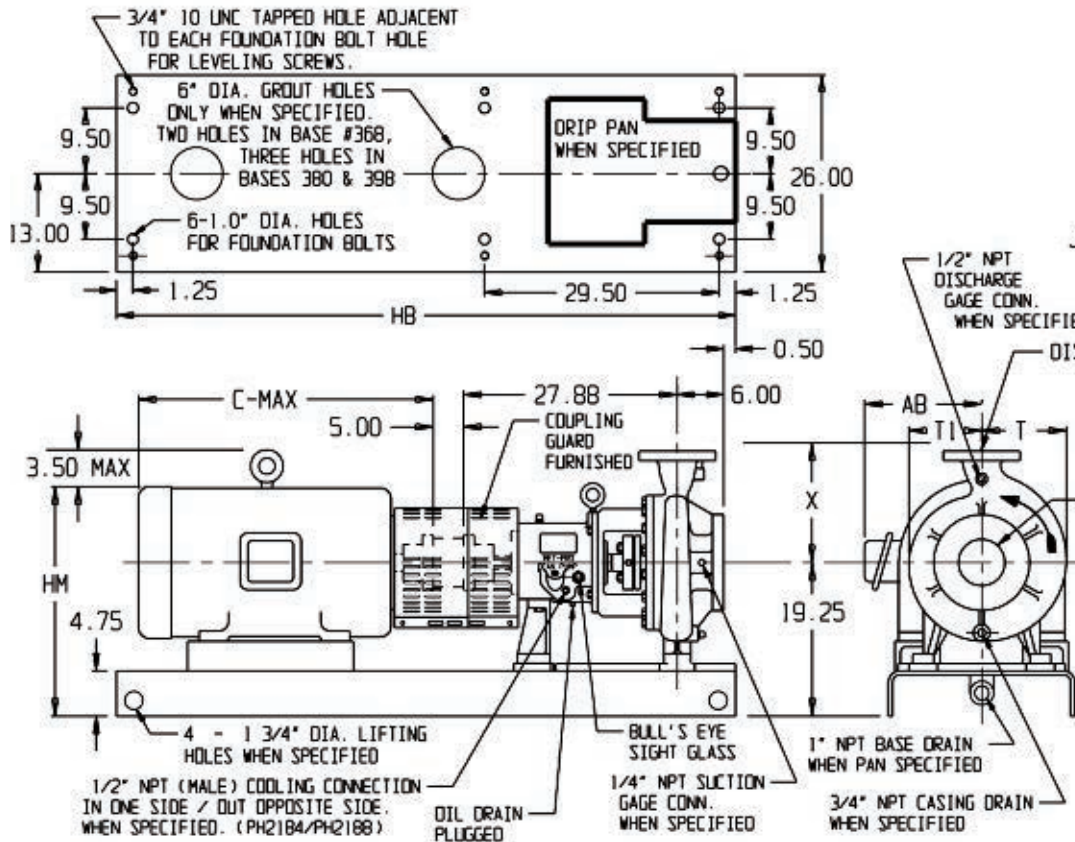

JACKETED PUMP CASING--pH2187 & pH2188

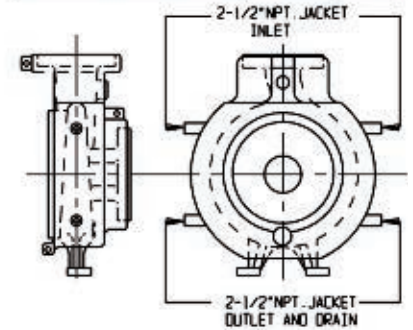

All dimensions in inches

PUMP SIZE	DISCHARGE					SUCTION					X
	SIZE	O.D.	THK	B.C.	BOLTS	SIZE	O.D.	THK	B.C.	BOLTS	
4x6x13 1/2	4	10	1.25	7.88	8-3/4	6	12.50	1.44	10.63	12-3/4	14.50
6x8x13 1/2	6	12.50	1.44	10.63	12-3/4	8	15	1.63	13	12-7/8	16.50

FRAME	ANSI BASE #	C	AB	HB	HM	FRAME	ANSI BASE #	C	AB	HB	HM
254T	368	23.13	11	68	26	364T	380	33.13	16.25	80	29
256T		24.88	11	68	26	365TS		32.50	16.25	80	29
284T		26.88	12.63	68	27	365T		33.88	16.25	80	29
286T		28.38	12.63	68	27	404TS		33.50	20.25	80	30
324TS	380	28.38	14.75	80	28	404T	398	36.50	20.25	80	30
324T		29.88	14.75	80	28	405TS		35.50	20.25	80	30
326TS		29.88	14.75	80	28	405T		38	20.25	80	30
326T		31.38	14.75	80	28	444TS		38.50	21.50	98	31.50
364TS		31.50	16.25	80	29	445TS		40.50	21.50	98	31.50

IMPORTANT: Do not use for construction unless certified.

DIMENSION DWG.
NO. PH2645

ALLOWABLE NOZZLE LOADS

The allowable loads given below and the procedure for application are as specified by the "American National Standard for Centrifugal and Vertical Pumps for Allowable Nozzle Loads", ANSI/HI 9.6.2-2001. For additional information and application, including examples, refer to this standard.

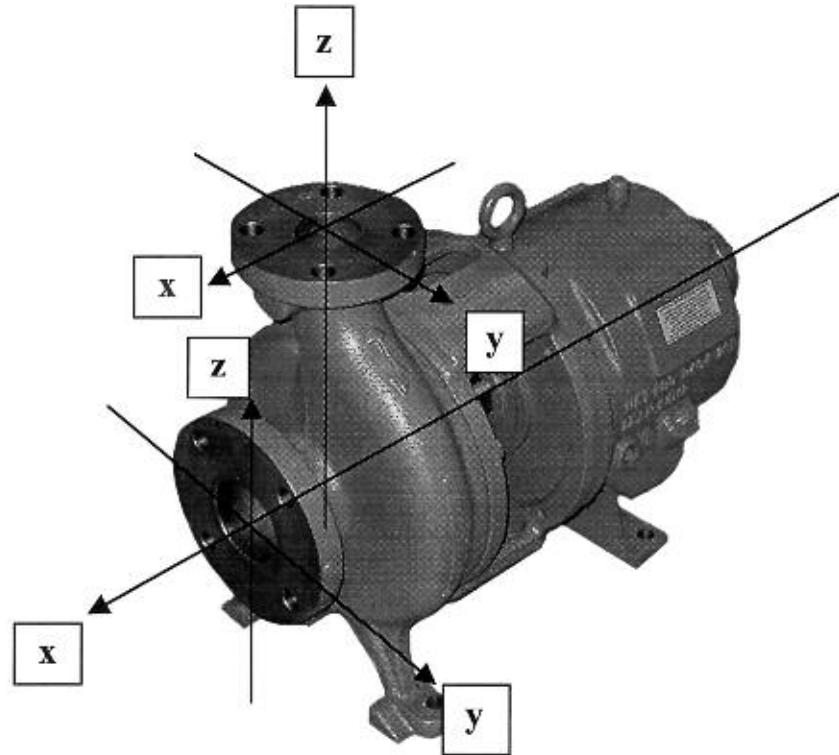

SYMBOLS

F_{xs} = applied force on x-axis on suction nozzle
 F_{ys} = applied force on y-axis on suction nozzle
 F_{zs} = applied force on z-axis on suction nozzle

M_{xs} = applied moment about x-axis on suction nozzle
 M_{ys} = applied moment about y-axis on suction nozzle
 M_{zs} = applied moment about z-axis on suction nozzle

F_{xd} = applied force on x-axis on discharge nozzle
 F_{yd} = applied force on y-axis on discharge nozzle
 F_{zd} = applied force on z-axis on discharge nozzle

M_{xd} = applied moment about x-axis on discharge nozzle
 M_{yd} = applied moment about y-axis on discharge nozzle
 M_{zd} = applied moment about z-axis on discharge nozzle

F_{xs} max = allowable force on x-axis on suction nozzle
 F_{ys} max = allowable force on y-axis on suction nozzle
 F_{zs} max = allowable force on z-axis on suction nozzle

M_{xs} max = allowable moment about x-axis on suction nozzle
 M_{ys} max = allowable moment about y-axis on suction nozzle
 M_{zs} max = allowable moment about z-axis on suction nozzle

F_{xd} max = allowable force on x-axis on discharge nozzle
 F_{yd} max = allowable force on y-axis on discharge nozzle
 F_{zd} max = allowable force on z-axis on discharge nozzle

M_{xd} max = allowable moment about x-axis on discharge nozzle
 M_{yd} max = allowable moment about y-axis on discharge nozzle
 M_{zd} max = allowable moment about z-axis on discharge nozzle

INSTRUCTIONS FOR USE OF ALLOWABLE LOADS

- 1) Determine the applied nozzle loads from the suction and discharge piping systems.
- 2) Use the correction factor from Table 5 for the pump material and operating temperature. For intermediate temperatures not shown in Table 5 linear interpolation is permitted. Multiply the values in Table 2 (For the applicable pump size) by the correction factor to obtain the allowable values.
- 3) If the base plate is metal, fully grouted, and anchored, evaluate the values of the de-rated Table 2 to see if any value is lower than the corresponding value in Table 1. If so, substitute the lower of the values into Table 1. No corrections are needed to Tables 3 and 4. Go to step 7.
- 4) If the base plate is un-grouted metal that is anchored down, use the corrected values of Table 2 from Step 2 above and 80% of the values in Tables 3 and 4. After adjusting the values in Tables 3 and 4, if the absolute values of any of them or the adjusted values of Table 2 (from Step 2 above) are lower than the corresponding values in Table 1, substitute the lower of the values into Table 1. Go to step 7.
- 5) If the base plate is grouted, anchored, and non-metallic, multiply the original values of Table 2 by 80%. Compare these corrected values with the Table 2 corrected values of Step 2 above. Use the lesser of the two corrected values as the Table 2 corrected values. Multiply the values of Tables 1, 3, and 4 by 80%. If any of the values of the de-rated table 2 are lower than the corresponding values in the de-rated Table 1, substitute the lower of the values into Table 1. Go to step 7.
- 6) If the base plate is un-grouted, nonmetallic, and is anchored down, multiply the original values of Table 2 by 70%. Compare these values with the Table 2 corrected values of Step 2 above. Use the lesser of the two corrected values as the Table 2 corrected values. Multiply the values of Tables 1, 3, and 4 by 70%. If any of the values of the de-rated Table 2 are lower than the corresponding values in the de-rated Table 1, substitute the lower of the values into Table 1.
- 7) Solve the equation of Equation Set #1 using the corrected allowable values of Table 1. The result for each of the twelve equations must be less than 1.00 for an acceptable application.
- 8) Solve the equation of Equation Set #2 using the corrected allowable values of Table 2. The result must be less than 1.0 to be acceptable.
- 9) Solve the equation of Equation Set #3 using the allowable (or corrected values if the base plate is either non-metal or un-grouted) values from Table 3. The result must be between -1.0 and +1.0 to be acceptable.
- 10) Solve the equation of Equation Set #4 using the allowable (or corrected values if the base plate is either non-metal or un-grouted) values from Table 4. The result must be between -1.0 and +1.0 to be acceptable.
- 11) Use the solution of equation 3(a) and the solution of equation 4(b) to solve equation #5. The result must be less than 1.0.
- 12) If all the solutions of all the equation sets result in acceptable values, the loads are within acceptable limits.

EQUATION SETS			
SET	EQUATIONS	REFERENCE	REMARKS
1	$\left \frac{F_{xs}}{F_{xs \max}} \right \leq 1.0, \left \frac{F_{ys}}{F_{ys \max}} \right \leq 1.0, \left \frac{F_{zs}}{F_{zs \max}} \right \leq 1.0, \left \frac{M_{xs}}{M_{xs \max}} \right \leq 1.0, \left \frac{M_{ys}}{M_{ys \max}} \right \leq 1.0, \left \frac{M_{zs}}{M_{zs \max}} \right \leq 1.0,$ $\left \frac{F_{xd}}{F_{xd \max}} \right \leq 1.0, \left \frac{F_{yd}}{F_{yd \max}} \right \leq 1.0, \left \frac{F_{zd}}{F_{zd \max}} \right \leq 1.0, \left \frac{M_{xd}}{M_{xd \max}} \right \leq 1.0, \left \frac{M_{yd}}{M_{yd \max}} \right \leq 1.0, \left \frac{M_{zd}}{M_{zd \max}} \right \leq 1.0$	Table 1	Individual Loading
2	$\frac{1}{2} \times \left[\left \frac{F_{xs}}{F_{xs \max}} \right + \left \frac{F_{ys}}{F_{ys \max}} \right + \left \frac{F_{zs}}{F_{zs \max}} \right + \left \frac{M_{xs}}{M_{xs \max}} \right + \left \frac{M_{ys}}{M_{ys \max}} \right + \left \frac{M_{zs}}{M_{zs \max}} \right + \left \frac{F_{xd}}{F_{xd \max}} \right + \left \frac{F_{yd}}{F_{yd \max}} \right + \left \frac{F_{zd}}{F_{zd \max}} \right + \left \frac{M_{xd}}{M_{xd \max}} \right + \left \frac{M_{yd}}{M_{yd \max}} \right + \left \frac{M_{zd}}{M_{zd \max}} \right \right] \leq 1.0$	Table 2	Nozzle Stress, Hold-Down Bolt Stress, Pump Slippage
3	$-1.0 \leq a = \left[\frac{F_{ys}}{F_{ys \max}} + \frac{M_{xs}}{M_{xs \max}} + \frac{M_{ys}}{M_{ys \max}} + \frac{M_{zs}}{M_{zs \max}} + \frac{F_{yd}}{F_{yd \max}} + \frac{M_{xd}}{M_{xd \max}} + \frac{M_{yd}}{M_{yd \max}} + \frac{M_{zd}}{M_{zd \max}} \right] \leq 1.0$	Table 3	y-Axis Movement
4	$-1.0 \leq b = \left[\frac{F_{xs}}{F_{xs \max}} + \frac{F_{zs}}{F_{zs \max}} + \frac{M_{xs}}{M_{xs \max}} + \frac{M_{ys}}{M_{ys \max}} + \frac{M_{zs}}{M_{zs \max}} + \frac{F_{xd}}{F_{xd \max}} + \frac{F_{yd}}{F_{yd \max}} + \frac{F_{zd}}{F_{zd \max}} + \frac{M_{xd}}{M_{xd \max}} + \frac{M_{yd}}{M_{yd \max}} + \frac{M_{zd}}{M_{zd \max}} \right] \leq 1.0$	Table 4	z-Axis Movement
5	$\sqrt{a^2 + b^2} \leq 1.0$		Combined Axis Movement

Notes:

- 1) The loads shown in Tables 1 through 4 are for a pump mounted upon a fully grouted metal base plate with anchor bolts.
 - 2) The loads given in Tables 1 through 4 are for pumps constructed of 316 Stainless Steel when operated between -20°F and 100°F.
 - 3) The temperature for a corresponding allowable nozzle load is the temperature of the pumped liquid.
 - 4) For an individual (single) load, the value of the applied load must not exceed the maximum allowable value, for that location, given in Table 1. i.e. The applied load divided by the allowable load must be less than or equal to 1.0.
 - 5) For a combination of more than one force and/or moment, the applied loads must not exceed any limit of any Equation (Sets 2 through 5) or any table (2 through 4).
 - 6) When combining loads, the absolute value of any individual load must not exceed the value given in Table 1.
 - 7) The loads in the tables must be multiplied by adjustment factors when applicable. The lowest correction factor must be applied when more than one adjustment factor is involved. There are cases where one adjustment factor is applied in Table 2 and another adjustment factor is applied to Tables 3 and 4.
- Adjustment of allowable loads is required for:
- Pump constructed of a material other than 316 S/S.
 - Pumping liquid at temperatures above 100°F.
 - The base plate is not grouted.
 - The base plate is nonmetallic.

TABLE 1 – ALLOWABLE INDIVIDUAL NOZZLE LOADS

ANSI Size	Pump Size	Suction						Discharge					
		Forces (lb)			Moments (ft-lb)			Forces (lb)			Moments (ft-lb)		
		F _{xs} max	F _{ys} max	F _{zs} max	M _{xs} max	M _{ys} max	M _{zs} max	F _{xd} max	F _{yd} max	F _{zd} max	M _{xd} max	M _{yd} max	M _{zd} max
PH2110													
AA	1x1½x6	1050	750	750	720	170	170	800	1350	3000	410	410	410
AB	1½x3x6	1050	1240	1250	900	490	490	800	1350	3000	500	550	510
AC	2x3x6	1050	1240	1250	900	490	490	800	1350	3000	500	550	510
AA	1x1½x8	1050	1210	1210	720	190	190	800	1350	3000	360	360	360
AB	1½x3x8	1050	1240	1250	900	490	490	800	1350	3000	440	440	440
PH2140													
A05	1x2x8½	2340	960	960	1270	200	200	1400	1350	3250	660	660	660
A50	1½x3x8½	2700	1350	1500	1300	370	370	1400	1350	3250	460	460	460
A60	2x3x8½	2700	1350	1500	1300	600	600	1400	1350	3250	660	660	660
A70	3x4x8½ #1	2700	1350	1500	1300	350	350	1400	1350	3250	1200	1460	690
	3x4x8½ #2	2700	1350	1500	1300	350	350	1400	1350	3250	1200	1460	690
A05	1x2x10	2340	960	960	1270	220	220	1400	1350	3250	660	660	660
A50	1½x3x10	2700	1350	1500	1300	420	420	1400	1350	3250	370	370	370
A60	2x3x10	2700	1350	1480	1300	310	310	1400	1350	3250	560	560	560
A70	3x4x10 #1	2300	1350	1500	1300	310	310	1400	1350	3250	1200	1460	690
	3x4x10 #2	2300	1350	1500	1300	310	310	1400	1350	3250	1200	1460	690
A20	1½x3x11½	2700	1350	1500	1300	670	670	1400	1350	3250	530	530	530
A30	2x3x11½	1920	1230	1230	1300	350	350	1400	1350	3250	1200	1270	690
A40	3x4x11½	2700	1350	1500	1300	400	400	1400	1350	3250	1200	1500	690
A80	4x6x11½	2700	1350	1500	1300	1100	1100	1400	1350	3250	1200	1500	690
A20	1½x3x13½	2700	1350	1500	1300	670	670	1400	1350	3250	530	530	530
A30	2x3x13½	1920	1230	1230	1300	350	350	1400	1350	3250	1200	1270	690
A40	3x4x13½	2700	1350	1500	1300	400	400	1400	1350	3250	1200	1500	690
PH2170													
A80	4x6x13½	2700	1350	1500	1300	1300	1100	1400	1350	3250	1200	1500	690
PH3170													
A20	1½x3x13½	2700	1350	1500	1300	670	670	1400	1350	3250	530	530	530
A30	2x3x13½	1920	1230	1230	1300	350	350	1400	1350	3250	1200	1270	690
A40	3x4x13½	2700	1350	1500	1300	400	400	1400	1350	3250	1200	1500	690
PH2180													
	4x6x13½	2700	1350	1500	1300	1170	1100	1400	1350	3250	1200	1500	690
	6x8x13½	3500	3180	2000	1500	1170	1170	1500	3000	3500	1250	2840	2840

TABLE 2 – ALLOWABLE COMBINATION NOZZLE LOADS FOR NOZZLE STRESS, HOLD-DOWN BOLT STRESS, AND PUMP SLIPPAGE ON BASEPLATE

ANSI Size	Pump Size	Suction						Discharge					
		Forces (lb)			Moments (ft-lb)			Forces (lb)			Moments (ft-lb)		
		F _{xs} max	F _{ys} max	F _{zs} max	M _{xs} max	M _{ys} max	M _{zs} max	F _{xd} max	F _{yd} max	F _{zd} max	M _{xd} max	M _{yd} max	M _{zd} max
PH2110													
AA	1x1½x6	2020	750	750	1830	170	170	2020	1350	6240	410	410	410
AB	1½x3x6	2020	1240	2110	2290	490	490	2020	1350	6240	550	550	510
AC	2x3x6	2020	1240	2110	2290	490	490	2020	1350	6240	550	550	510
AA	1x1½x8	2020	1210	1210	1830	190	190	2020	1350	6240	360	360	360
AB	1½x3x8	2020	1240	1640	2290	490	490	2020	1350	6240	440	440	440
PH2140													
A05	1x2x8½	2340	960	910	3640	200	200	2020	1350	6240	660	660	660
A50	1½x3x8½	2700	1350	1820	3730	370	370	2020	1350	6240	460	460	460
A60	2x3x8½	2700	1350	2490	3730	600	600	1970	1350	6240	660	660	660
A70	3x4x8½ #1	2700	1350	1840	3730	350	350	2020	1350	6240	1460	1460	690
	3x4x8½ #2	2700	1350	1840	3730	350	350	2020	1350	6240	1460	1460	690
A05	1x2x10	2340	960	960	3640	220	220	2020	1350	6240	660	660	660
A50	1½x3x10	2700	1350	1910	3730	420	420	1940	1350	6240	370	370	370
A60	2x3x10	2700	1350	1480	3730	310	310	2020	1350	6240	560	560	560
A70	3x4x10 #1	2300	1350	1640	3730	310	310	2020	1350	6240	1460	1460	690
	3x4x10 #2	2300	1350	1640	3730	310	310	2020	1350	6240	1460	1460	690
A20	1½x3x11½	2700	1350	3060	3730	670	670	2020	1350	6240	530	530	530
A30	2x3x11½	1920	1230	1230	3730	350	350	2020	1350	6240	1460	1460	690
A40	3x4x11½	2700	1350	2390	3730	400	400	2020	1350	6240	1730	1730	690
A80	4x6x11½	2700	1350	6240	3730	1100	1100	2020	1350	6240	2150	2150	690
A20	1½x3x13½	2700	1350	3060	3730	670	670	2020	1350	6240	530	530	530
A30	2x3x13½	1920	1230	1230	3730	350	350	2020	1350	6240	1460	1460	690
A40	3x4x13½	2700	1350	2390	3730	400	400	2020	1350	6240	1730	1730	690
PH2170													
A80	4x6x13½	2700	1350	6240	3730	4980	1100	2020	1350	6240	2150	2150	690
PH3170													
A20	1½x3x13½	2700	1350	3060	3730	670	670	2020	1350	6240	530	530	530
A30	2x3x13½	1920	1230	1230	3730	350	350	2020	1350	6240	1460	1460	690
A40	3x4x13½	2700	1350	2390	3730	400	400	2020	1350	6240	1730	1730	690
PH2180													
	4x6x13½	2700	1350	5080	3730	1170	1100	2020	1350	6240	2150	2150	690
	6x8x13½	6360	3180	5080	8970	1170	1170	6360	3180	13460	6780	3850	3840

TABLE 3 – ALLOWABLE COMBINATION NOZZLE LOADS FOR Y-AXIS MOVEMENT

Pump Size	Suction						Discharge					
	Forces (lb)			Moments (ft-lb)			Forces (lb)			Moments (ft-lb)		
		F_{ys} max		M_{xs} max	M_{ys} max	M_{zs} max		F_{yd} max		M_{xd} max	M_{yd} max	M_{zd} max
PH2110		-2000		900	1200	1250		1500		-500	1500	1250
PH2140/2170/3170		-3500		1300	1300	3000		2500		-1200	1500	3000
PH2180		-5000		1500	2000	4000		3000		-1250	5000	4000

TABLE 4 – ALLOWABLE COMBINATION NOZZLE LOADS FOR Z-AXIS MOVEMENT

Pump Size	Suction						Discharge					
	Forces (lb)			Moments (ft-lb)			Forces (lb)			Moments (ft-lb)		
	F_{xs} max		F_{zs} max	M_{xs} max	M_{ys} max	M_{zs} max	F_{xd} max	F_{yd} max	F_{zd} max	M_{xd} max	M_{yd} max	M_{zd} max
PH2110	1050		-1250	1500	1200	-2500	800	2000	-3000	-1500	1000	-2500
PH2140/2170/3170	3500		-1500	1500	1300	-3500	1400	2500	-3250	-1500	2150	-3500
PH2180	3500		-2000	1500	4100	-4000	1500	4000	-3500	-1500	5000	-4000

TABLE 5 – PUMP TEMPERATURE AND MATERIAL ADJUSTMENT VALUES TO BE USED ON TABLE 2 VALUES

Material	Temperature - °F									
	-20 to 100	150	200	250	300	350	400	450	500	
Ductile Iron (Class 22) ASTM-A395	0.89	0.86	0.83	0.80	0.78	0.75	0.73	0.71	0.69	
Type 316 S/S (Class 50) ASTM-A744 Grade CF-8M	1.00	0.93	0.86	0.82	0.78	0.75	0.72	0.69	0.67	
Type Alloy 20 S/S (Class 60) ASTM-A744 Grade CN-7M	0.83	0.80	0.77	0.75	0.73	0.70	0.67	0.66	0.65	
Type CD4MCu S/S ASTM-A351 Grade CD4MCu	1.00	1.00	1.00	1.00	1.00	0.99	0.98	0.95	0.92	
Hastelloy – C ASTM-A494 Grade CW-12MW	1.00	1.00	1.00	1.00	1.00	0.99	0.98	0.95	0.92	

FOR PH2110, PH2140, PH2170, PH3170 & PH2180 SERIES PUMPS
 SCHEMATIC DRAWINGS – COMPONENTS FURNISHED BY DEAN PUMP DIVISION

FOR CLEAN PUMPAGE

ANSI Plan 7311

Recirculation from pump discharge connection thru an orifice to seal flush connection.

- Terminal end of loop feeds to:
- Seal Chamber Connection
 - Mechanical Seal Gland Connection

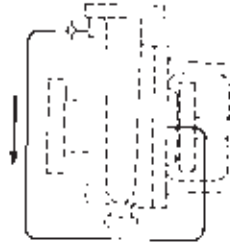

Part	Material Class 22-40	Material Class 50
Tubing	Steel	316 S/S
Orifice	316 S/S	316 S/S

ANSI Plan 7321

Recirculation from pump discharge connection thru an orifice, thru a heat exchanger to seal flush connection.

- Terminal end of loop feeds to:
- Seal Chamber Connection
 - Mechanical Seal Gland Connection

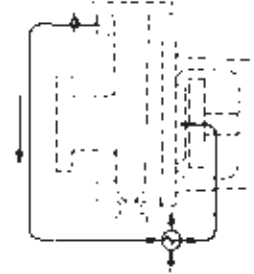

Part	Material Class 22-40	Material Class 50
Tubing	Steel	316 S/S
Orifice	316 S/S	316 S/S
Heat Exchanger	Steel Tubes – C.I. Shell	316 S/S Tubes – C.I. Shell

ANSI Plan 7312

Recirculation from pump discharge connection thru a "Y" strainer, thru an orifice to seal flush connection.

- Terminal end of loop feeds to:
- Seal Chamber Connection
 - Mechanical Seal Gland Connection

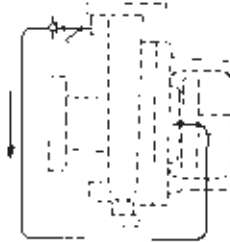

Part	Material Class 22-40	Material Class 50
Tubing	Steel	316 S/S
Orifice	316 S/S	316 S/S
"Y" Strainer	Steel – S/S Screen	316 S/S – S/S Screen

ANSI Plan 7322

Recirculation from pump discharge connection thru a "Y" strainer, thru an orifice, thru a heat exchanger to seal flush connection.

- Terminal end of loop feeds to:
- Seal Chamber Connection
 - Mechanical Seal Gland Connection

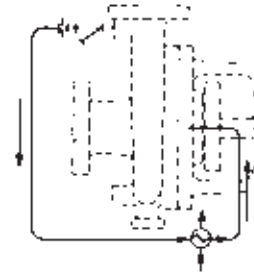

Part	Material Class 22-40	Material Class 50
Tubing	Steel	316 S/S
Orifice	316 S/S	316 S/S
"Y" Strainer	Steel – S/S Screen	316 S/S – S/S Screen
Heat Exchanger	Steel Tubes – C.I. Shell	316 S/S Tubes – C.I. Shell

FOR DIRTY OR SPECIAL PUMPAGE

ANSI Plan 7331

Recirculation from pump discharge connection thru cyclone separator, delivering clean pumpage to seal flush connection and pumpage with solids back to pump suction.

- Terminal end of loop feeds to:
- Seal Chamber Connection
 - Mechanical Seal Gland Connection

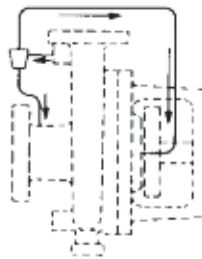

Part	Material Class 22-40	Material Class 50
Tubing	Steel	316 S/S
Separator	316 S/S	316 S/S

ANSI Plan 7332

Injection to seal flush connection from external source thru "Y" strainer, thru globe valve, past pressure gauge to seal flush connection.

- Terminal end of loop feeds to:
- Seal Chamber Connection
 - Mechanical Seal Gland Connection

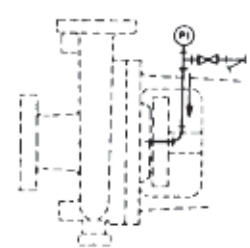

Part	Material Class 22-40	Material Class 50
Piping	Steel	316 S/S
"Y" Strainer	Steel – S/S Screen	316 S/S – S/S Screen
Globe Valve	Steel	316 S/S
Pressure Gauge	Steel	316 S/S

MAXIMUM PRESSURE – TEMPERATURE LIMITS

Piping and components containing the liquid to be pumped are good to the same pressure/temperature limits as the pump itself, as shown in the charts on page 3.

The heat exchanger used in plans 7321 and 7322 has a pressure limit of 130 psig on the cooling liquid side. If the cooling liquid is in a common line with cooling to the pump, the pressure will be limited to 125 psig as this is the limit of the pump jackets, as shown in the table on page 2.

Plan 7332 has an inlet pressure limit of 100 psig or the pressure limit of the mechanical seal that is installed in the pump, whichever is the lowest.

LEGEND

Orifice		"Y" Strainer		Separator	
Globe Valve		Pressure Gauge		Heat Exchanger	

CECO Dean

(317) 293-2930 • E-mail: infohhs@onececo.com

CENTRIFUGAL PUMP PERFORMANCE DATA: CURVE PH1060-B1

PUMP SIZE: 1" X 1 1/2" X 6"

PUMP TYPE: PH2110

MAXIMUM SOLIDS 5/16" DIAMETER

1" DISCHARGE X 1 1/2" SUCTION

PUMP PERFORMANCE: This curve, based on extensive tests, defines the average performance of this pump for liquids having a viscosity of 70 SSU or less. Actual performance of individual units may differ slightly from the performance indicated on this curve. Pump applications made from the data contained herein are subject to confirmation and acceptance by our Engineering Department at our Indianapolis Office.

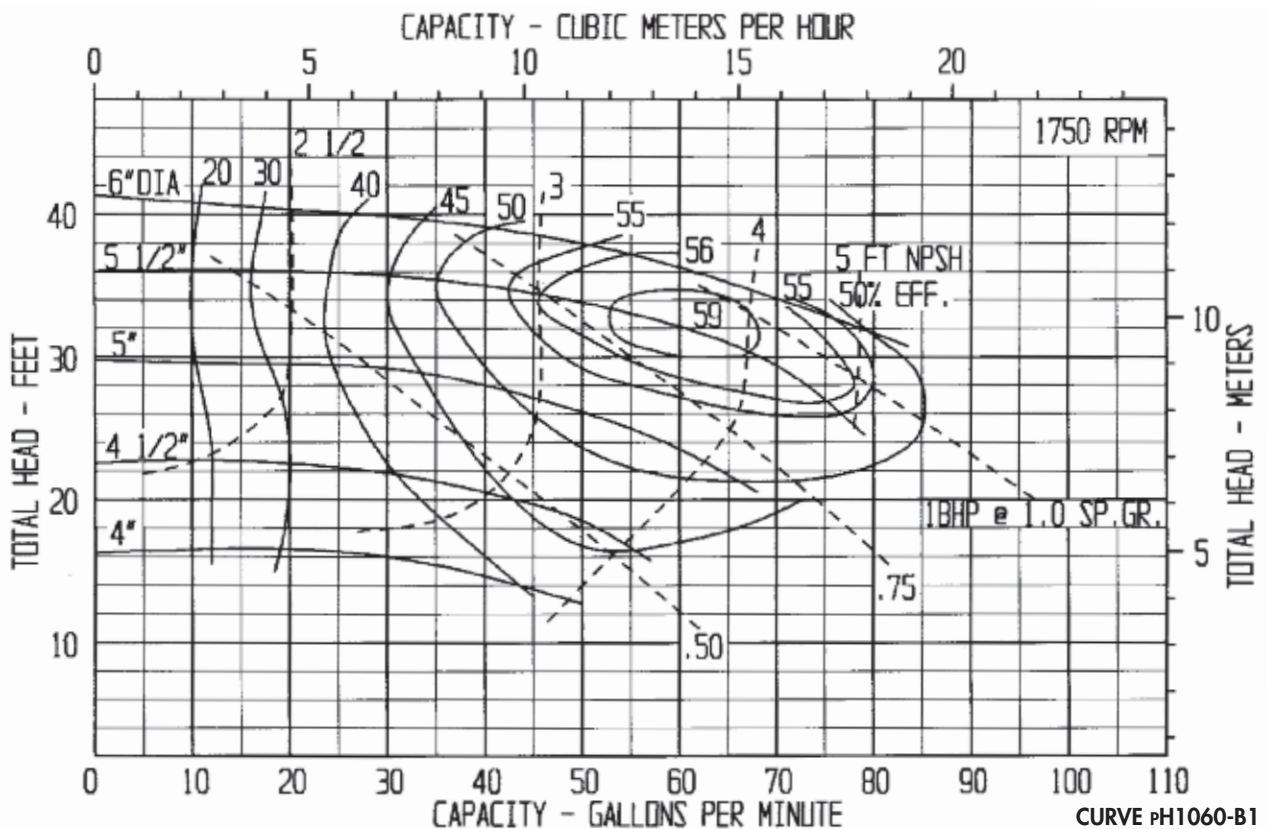
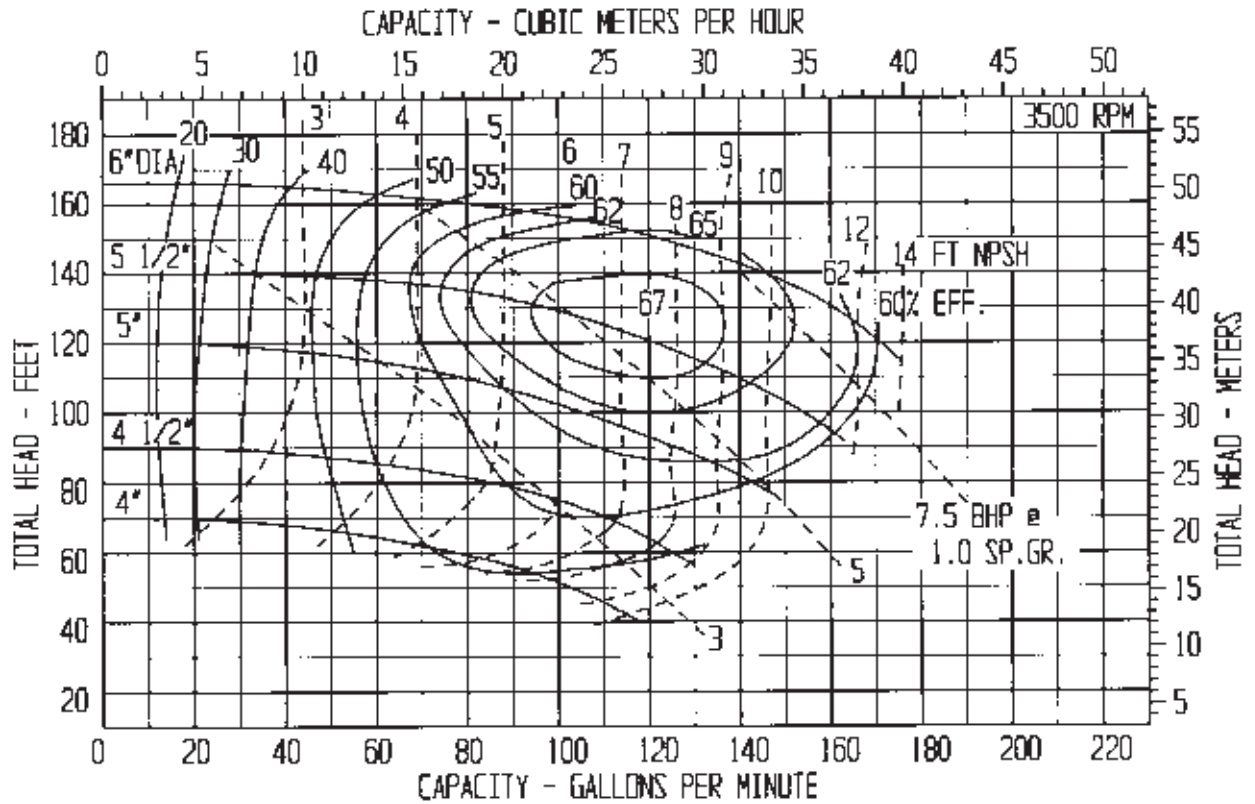

CURVE PH1060-B1

CECO Dean

(317) 293-2930 • E-mail: infohfs@onececo.com

CENTRIFUGAL PUMP PERFORMANCE DATA: CURVE pH1080-A2

PUMP SIZE: 1" X 1 1/2" X 8"

PUMP TYPE: pH2110

MAXIMUM SOLIDS 5/16" DIAMETER

1" DISCHARGE X 1 1/2" SUCTION

PUMP PERFORMANCE: This curve, based on extensive tests, defines the average performance of this pump for liquids having a viscosity of 70 SSU or less. Actual performance of individual units may differ slightly from the performance indicated on this curve. Pump applications made from the data contained herein are subject to confirmation and acceptance by our Engineering Department at our Indianapolis Office.

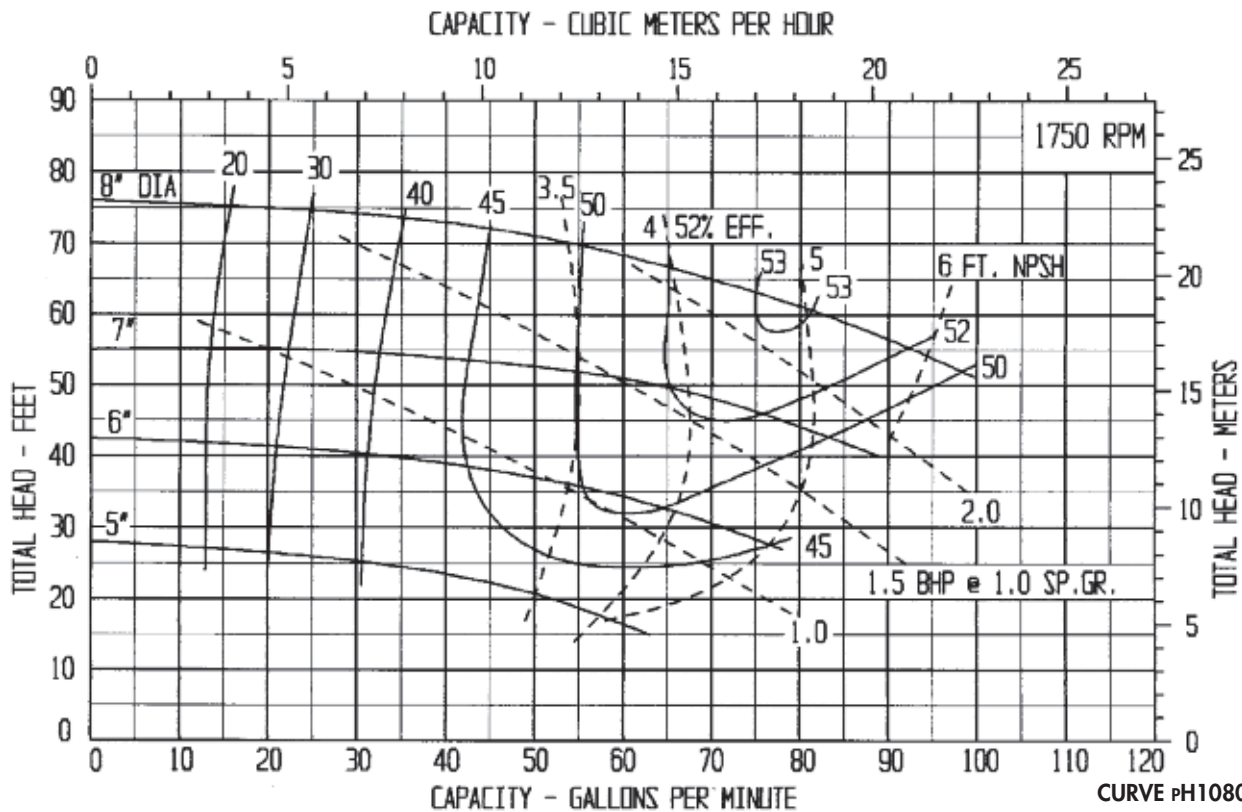
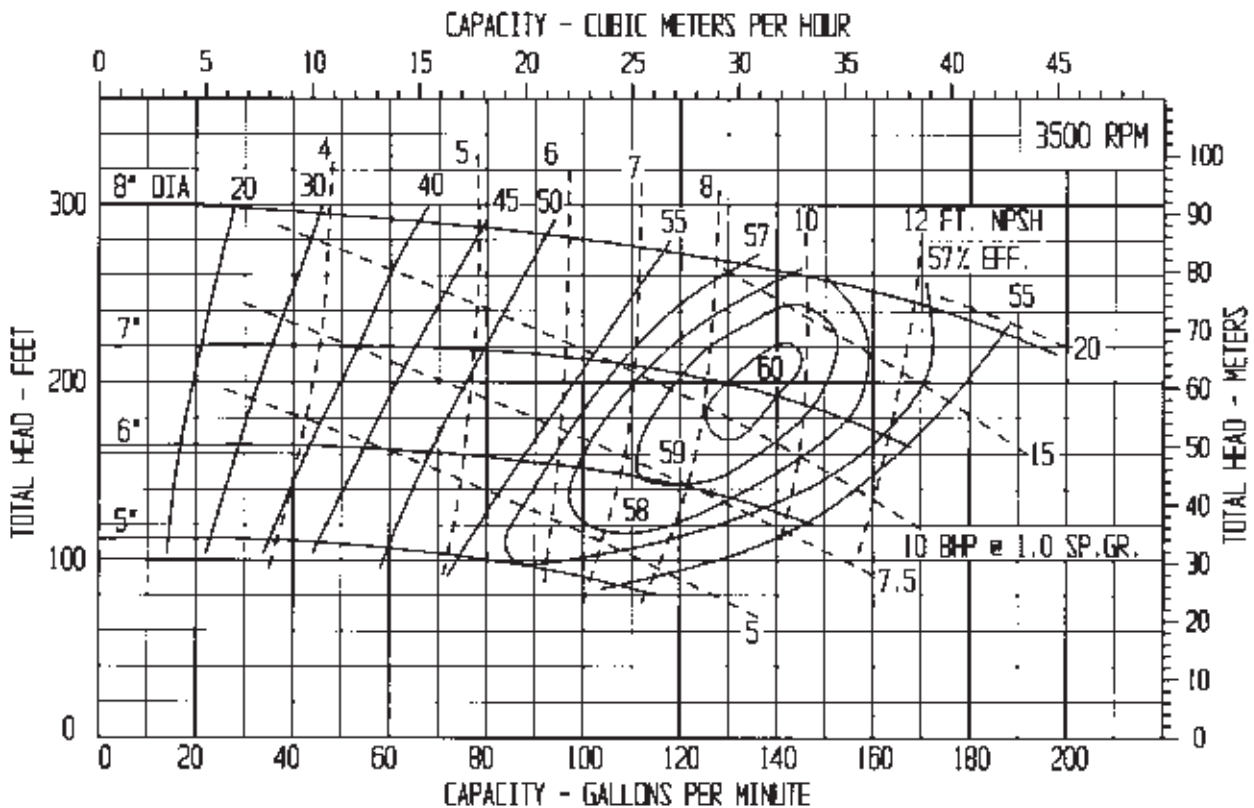

CURVE pH1080-A2

CECO Dean

(317) 293-2930 • E-mail: infohfs@onececo.com

CENTRIFUGAL PUMP PERFORMANCE DATA: CURVE PH1560-B1

PUMP SIZE: 1 1/2" X 3" X 6"

PUMP TYPE: PH2110

MAXIMUM SOLIDS 3/8" DIAMETER

1 1/2" DISCHARGE X 3" SUCTION

PUMP PERFORMANCE: This curve, based on extensive tests, defines the average performance of this pump for liquids having a viscosity of 70 SSU or less. Actual performance of individual units may differ slightly from the performance indicated on this curve. Pump applications made from the data contained herein are subject to confirmation and acceptance by our Engineering Department at our Indianapolis Office.

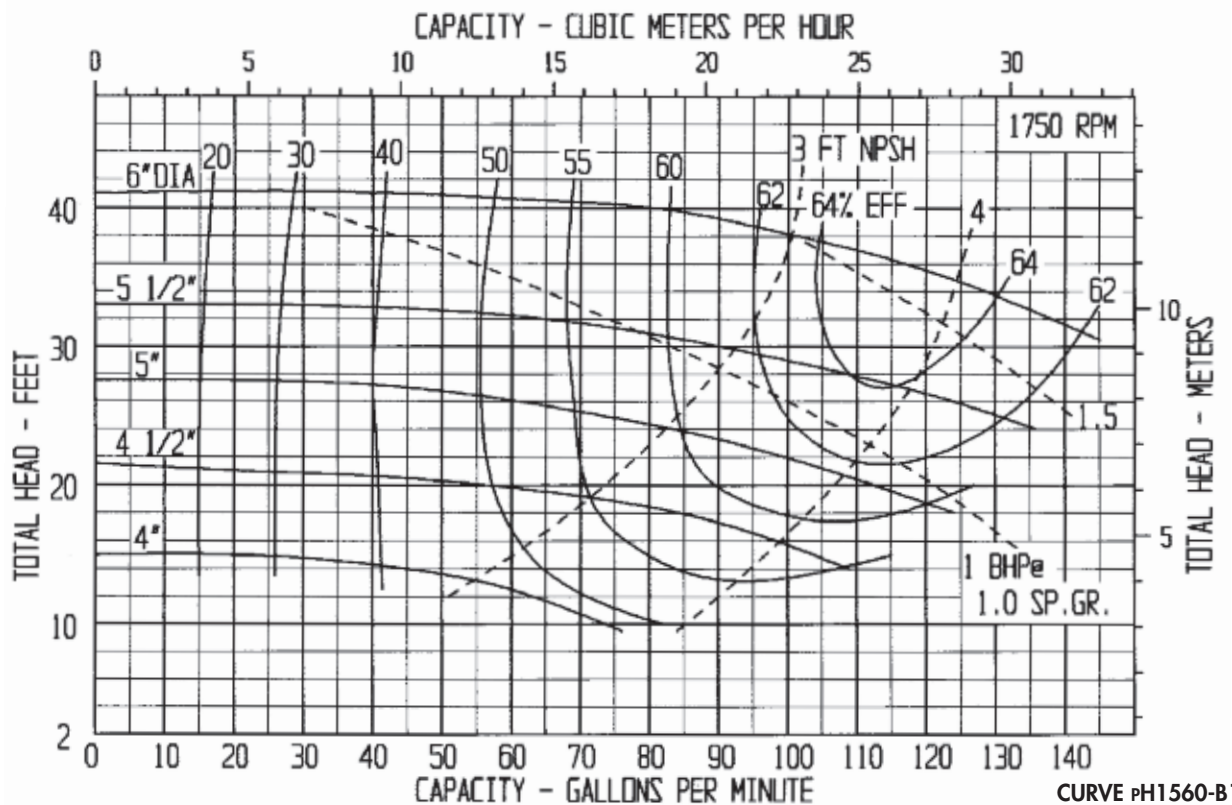
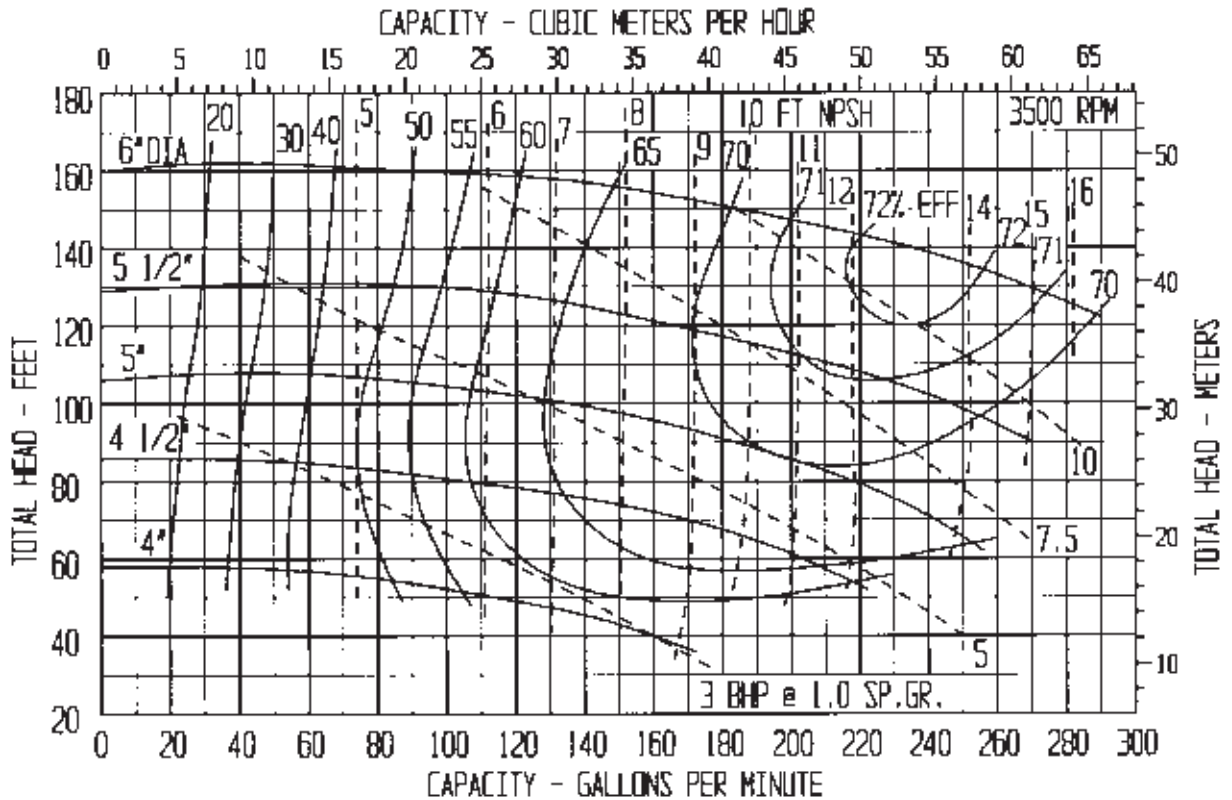

CURVE PH1560-B1

PUMP PERFORMANCE: This curve, based on extensive tests, defines the average performance of this pump for liquids having a viscosity of 70 SSU or less. Actual performance of individual units may differ slightly from the performance indicated on this curve. Pump applications made from the data contained herein are subject to confirmation and acceptance by our Engineering Department at our Indianapolis Office.

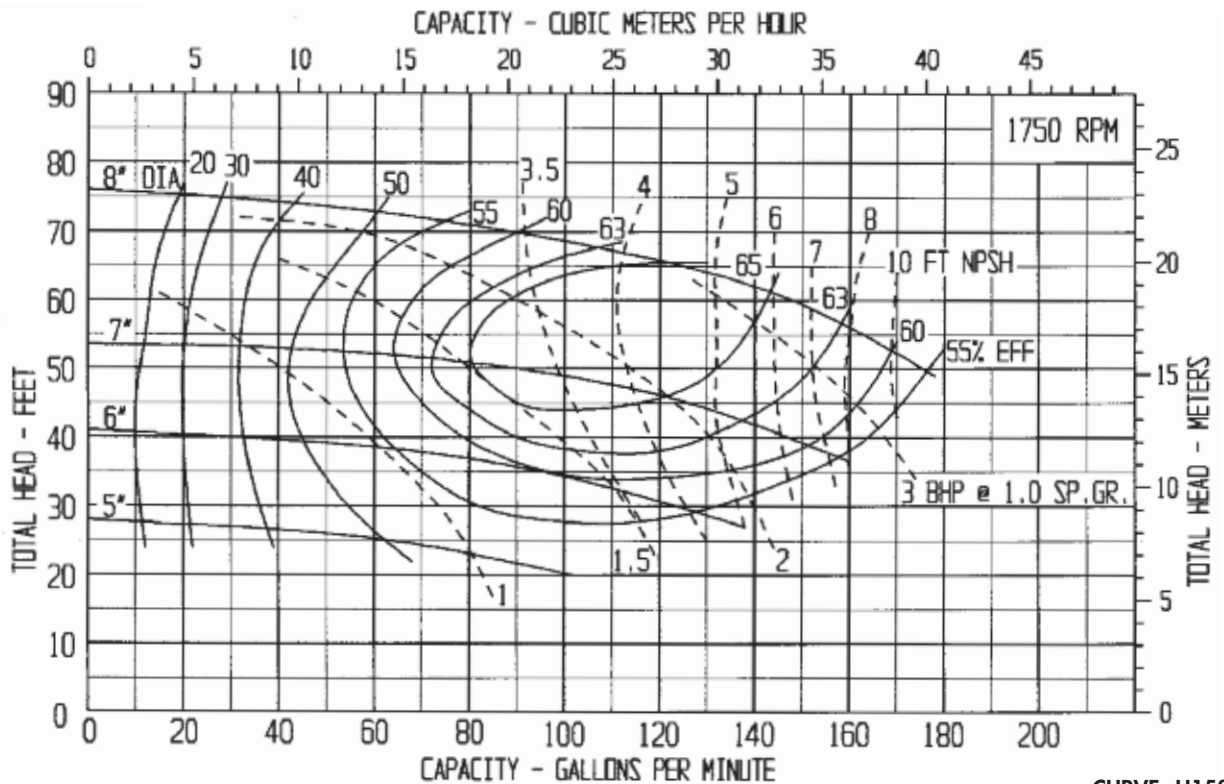
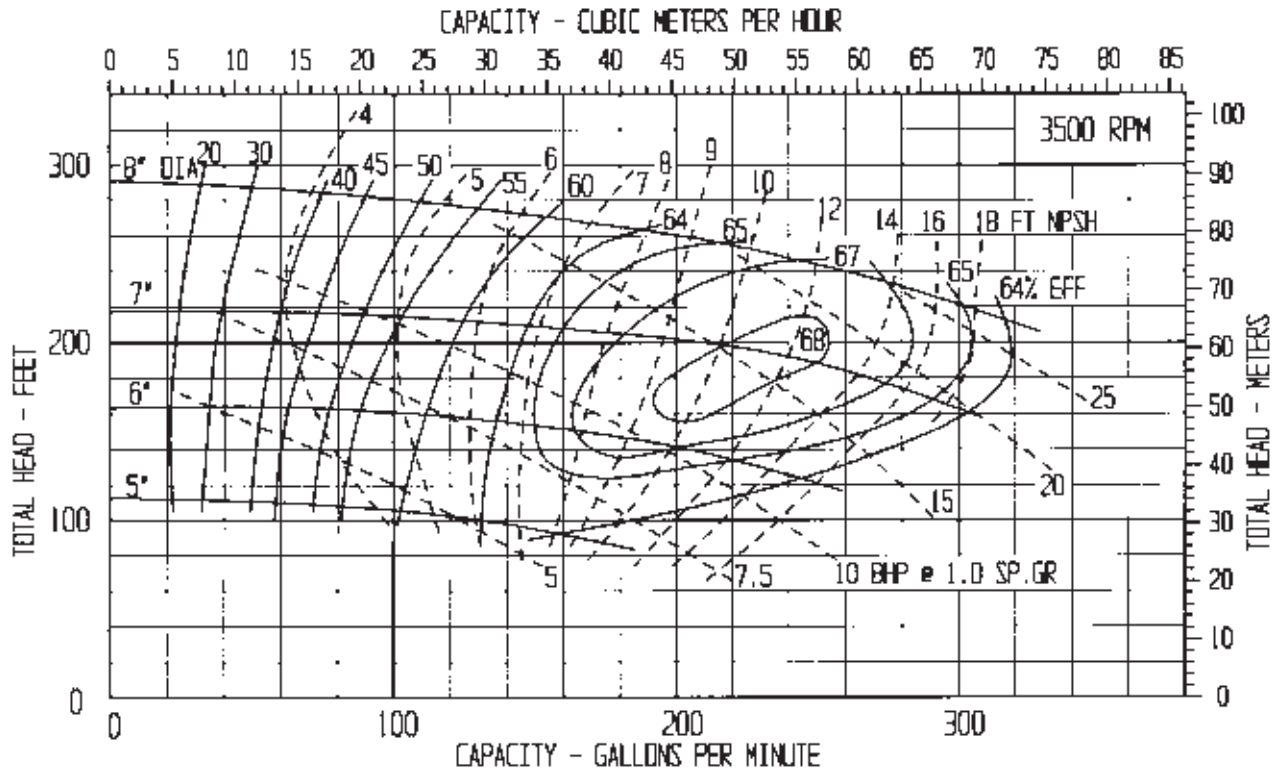

PUMP PERFORMANCE: This curve, based on extensive tests, defines the average performance of this pump for liquids having a viscosity of 70 SSU or less. Actual performance of individual units may differ slightly from the performance indicated on this curve. Pump applications made from the data contained herein are subject to confirmation and acceptance by our Engineering Department at our Indianapolis Office.

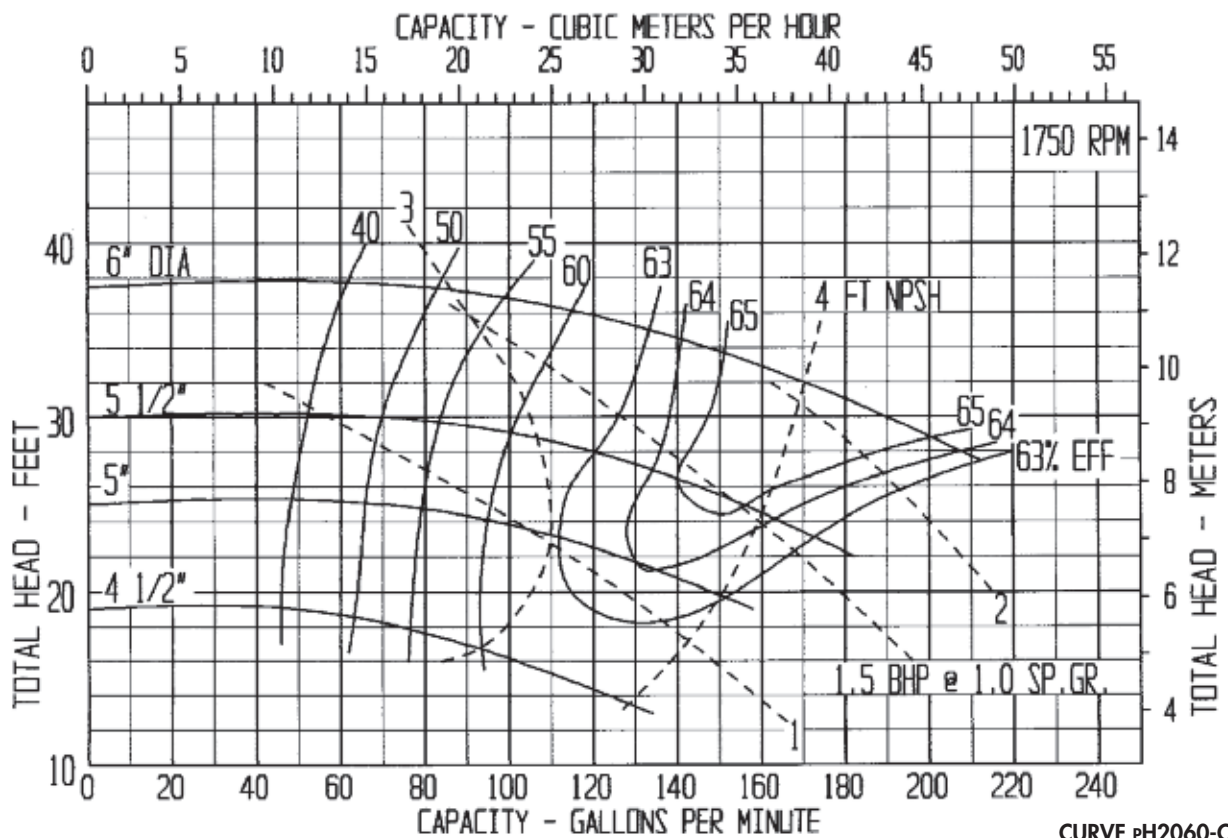
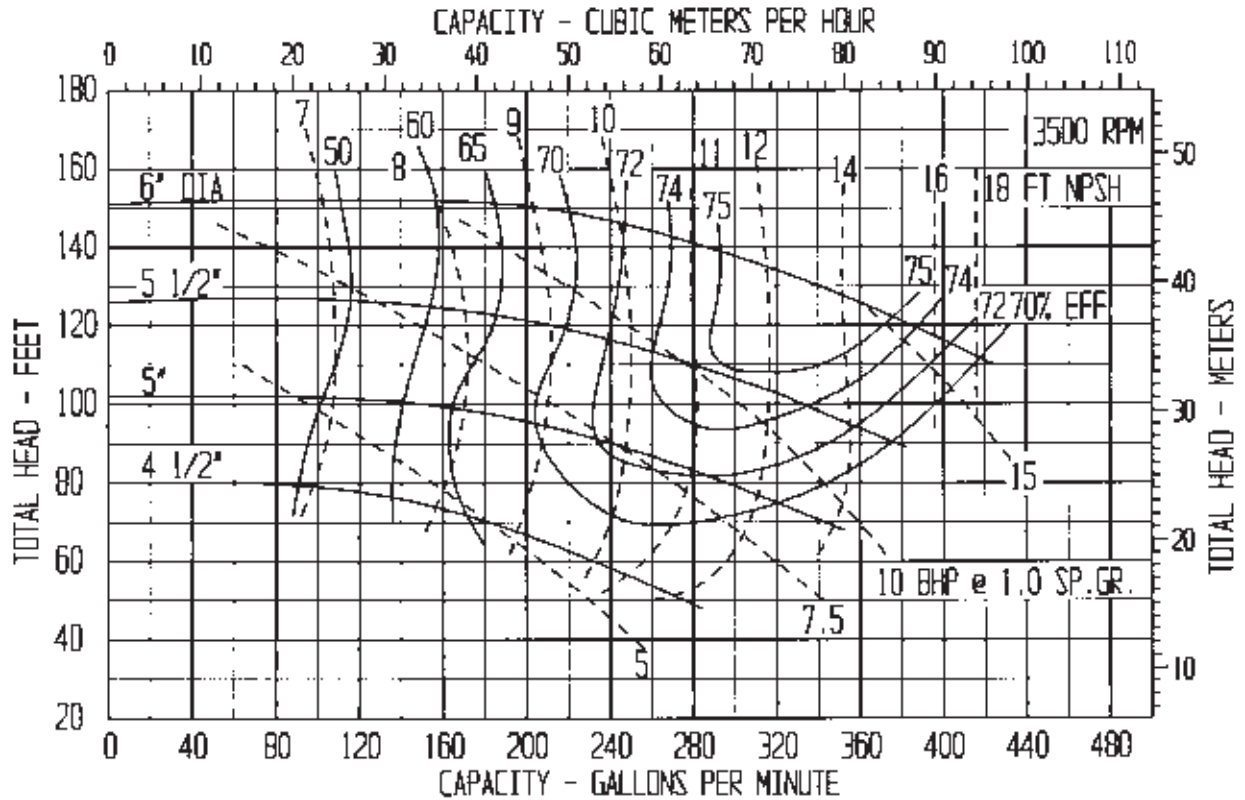

PUMP PERFORMANCE: This curve, based on extensive tests, defines the average performance of this pump for liquids having a viscosity of 70 SSU or less. Actual performance of individual units may differ slightly from the performance indicated on this curve. Pump applications made from the data contained herein are subject to confirmation and acceptance by our Engineering Department at our Indianapolis Office.

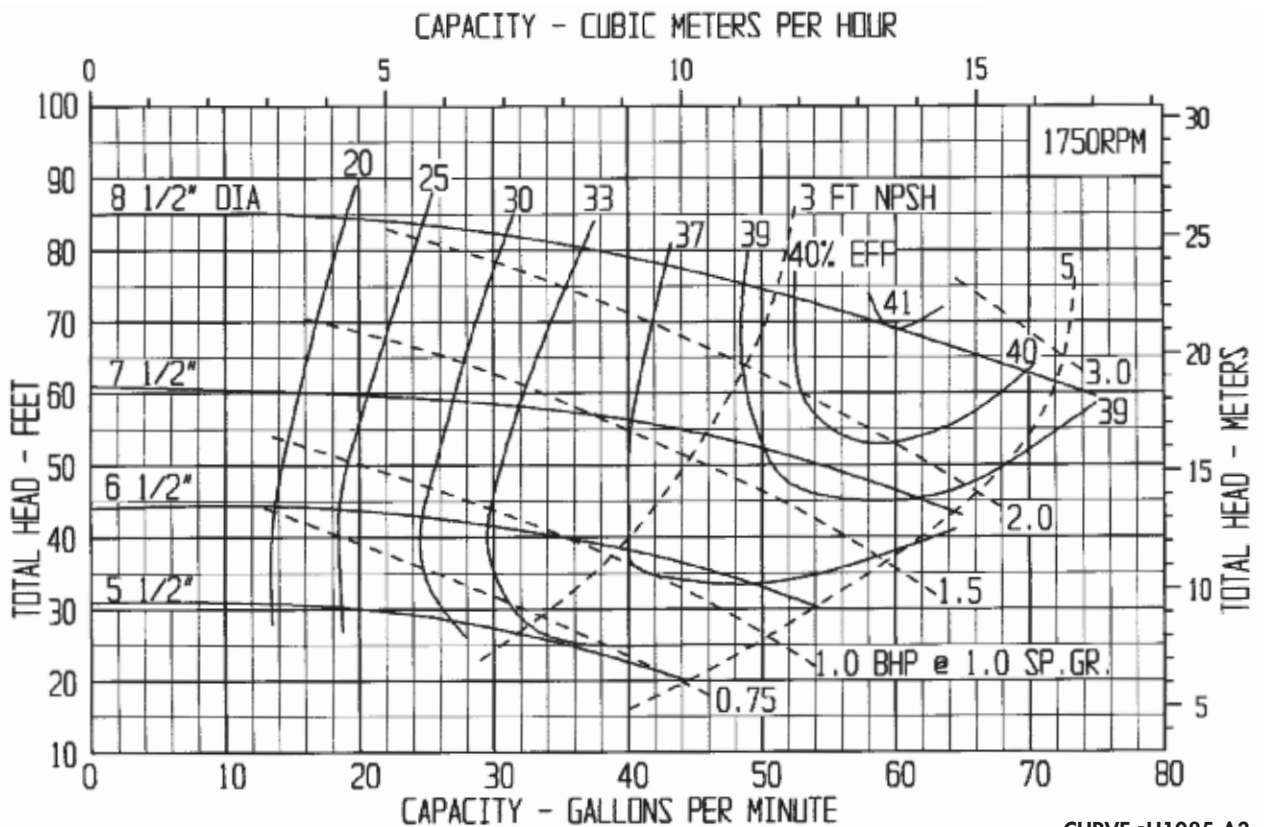
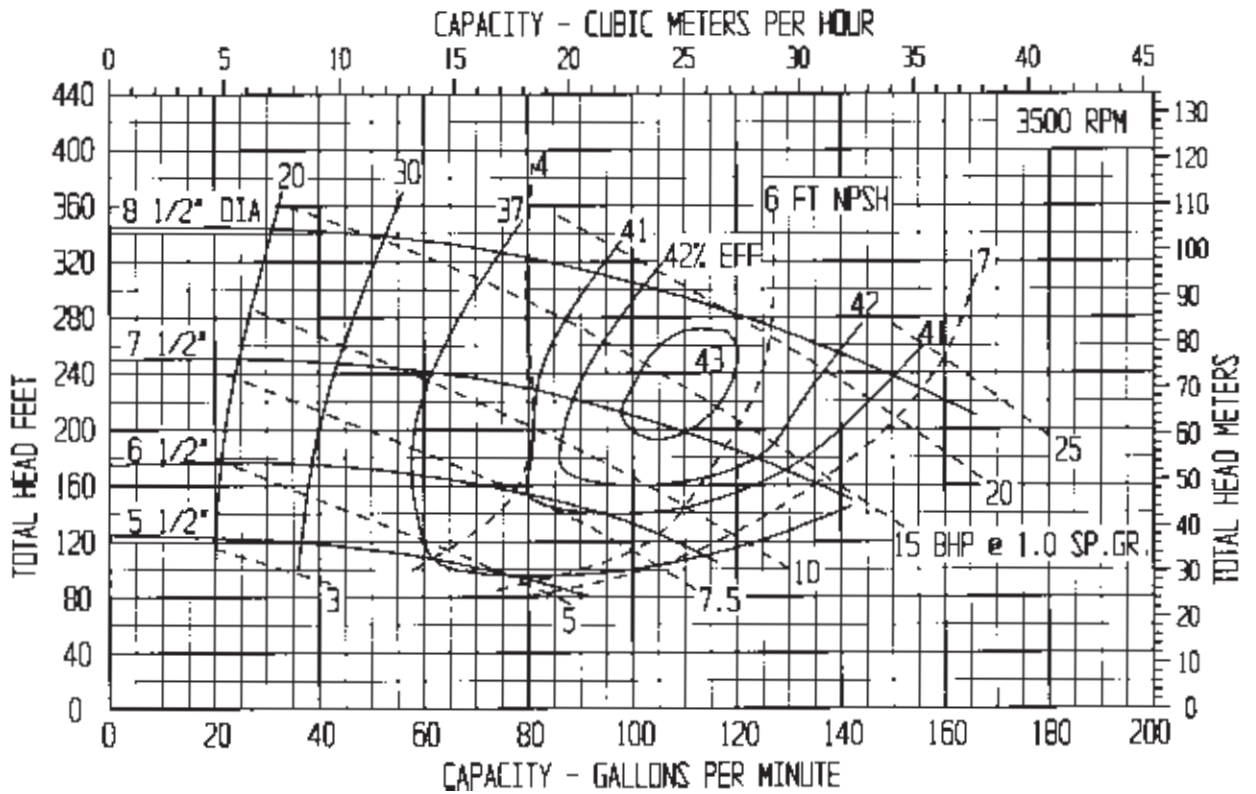

PUMP PERFORMANCE: This curve, based on extensive tests, defines the average performance of this pump for liquids having a viscosity of 70 SSU or less. Actual performance of individual units may differ slightly from the performance indicated on this curve. Pump applications made from the data contained herein are subject to confirmation and acceptance by our Engineering Department at our Indianapolis Office.

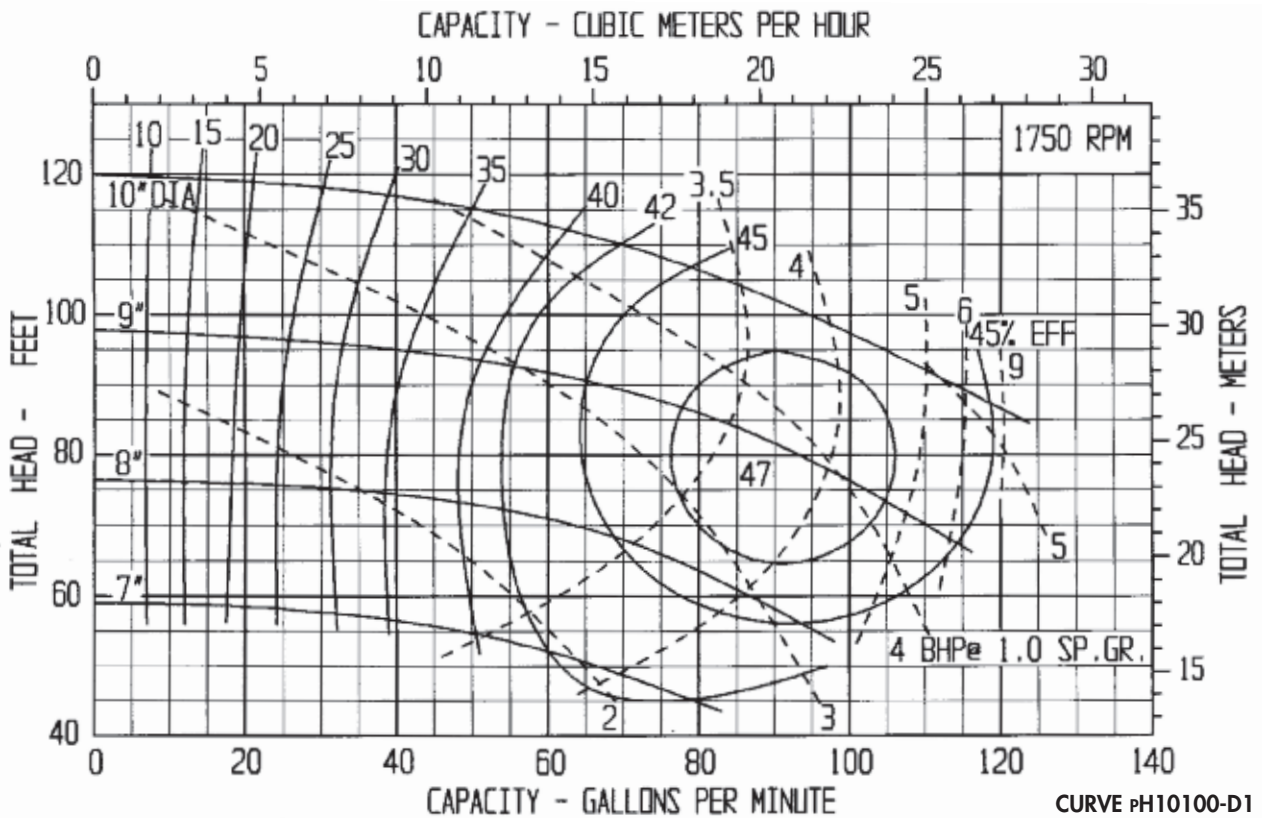
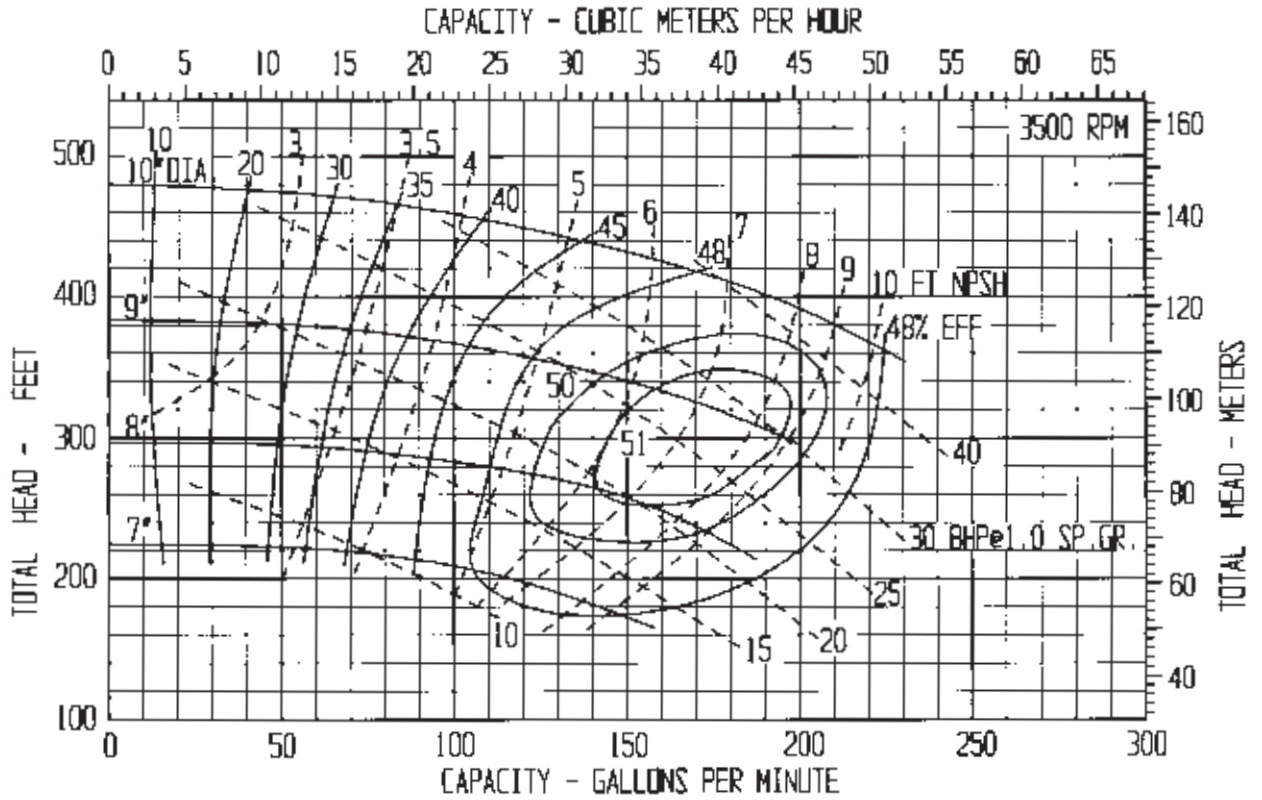

CURVE pH10100-D1

CECO Dean

(317) 293-2930 • E-mail: infohfs@onececo.com

CENTRIFUGAL PUMP PERFORMANCE DATA: CURVE pH1585-A2

PUMP SIZE: 1 1/2" X 3" X 8 1/2"

PUMP TYPE: pH2140

MAXIMUM SOLIDS 1/2" DIAMETER

1 1/2" DISCHARGE X 3" SUCTION

PUMP PERFORMANCE: This curve, based on extensive tests, defines the average performance of this pump for liquids having a viscosity of 70 SSU or less. Actual performance of individual units may differ slightly from the performance indicated on this curve. Pump applications made from the data contained herein are subject to confirmation and acceptance by our Engineering Department at our Indianapolis Office.

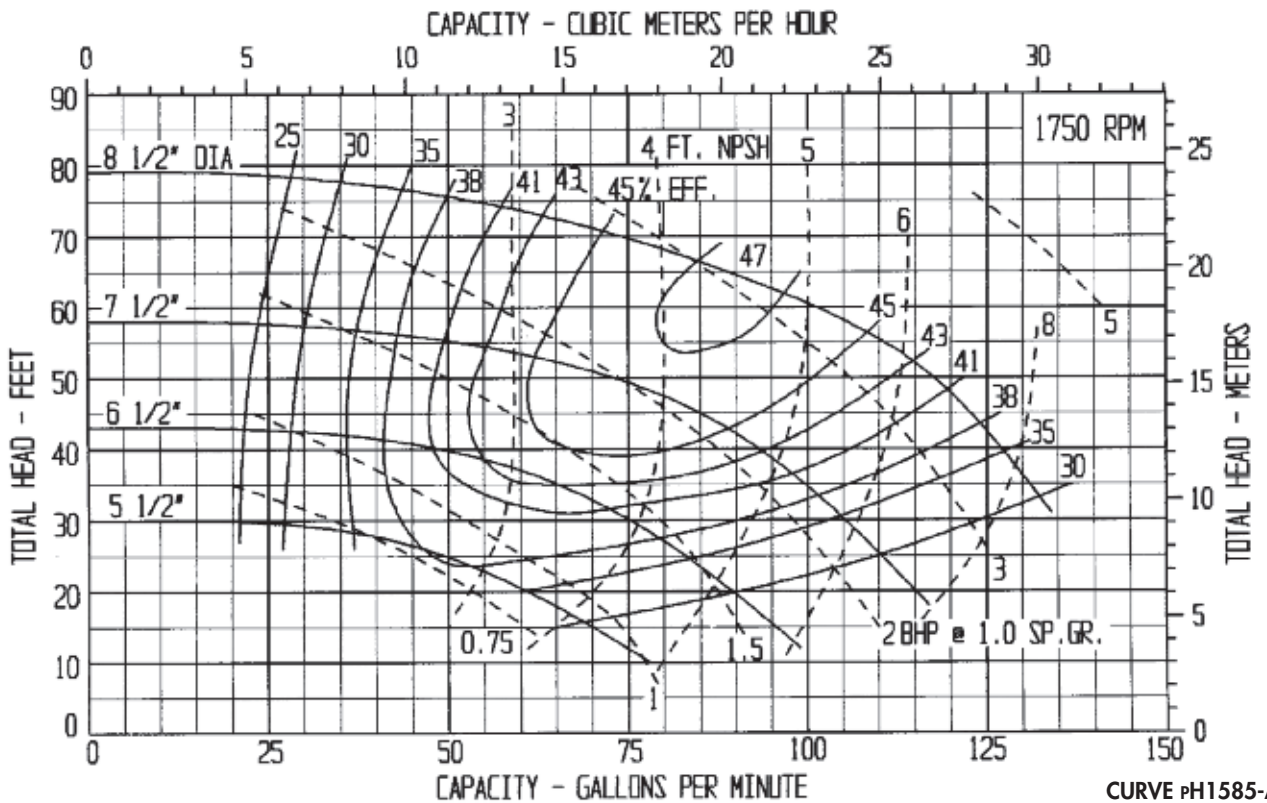
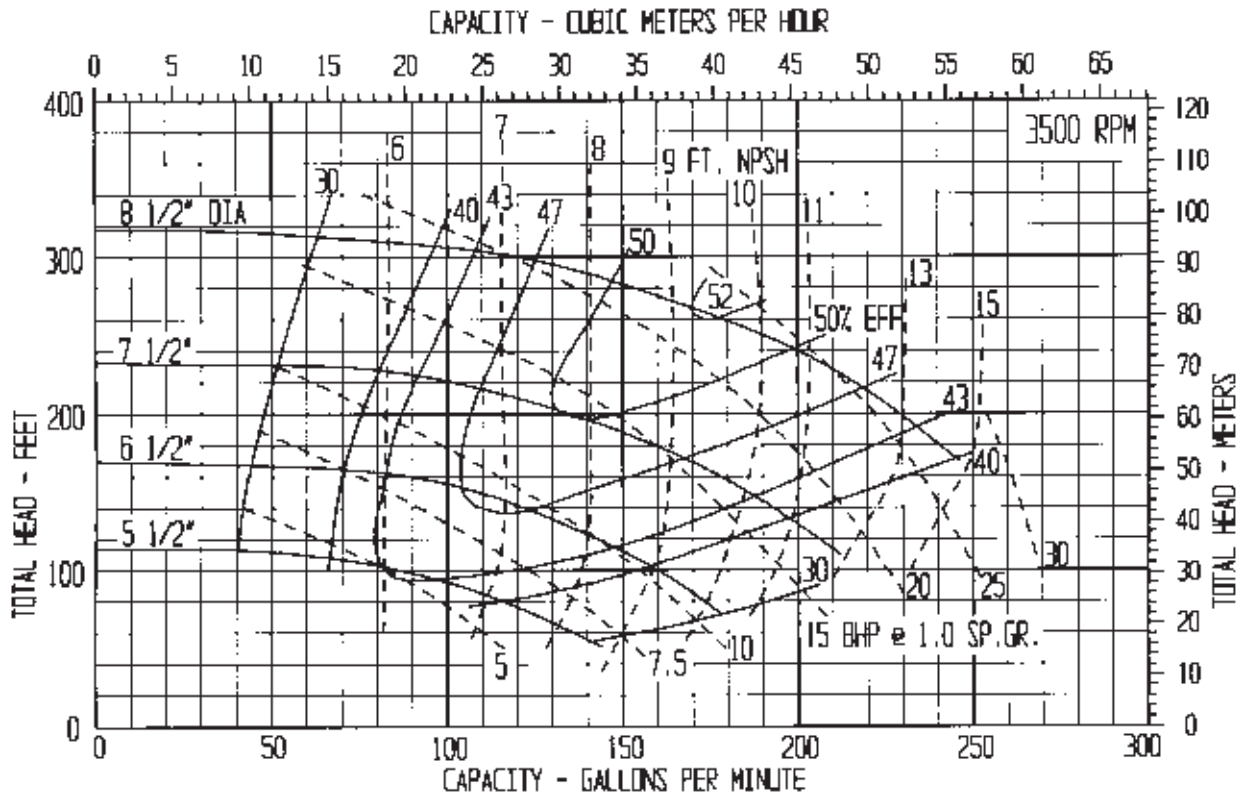

CURVE pH1585-A2

PUMP PERFORMANCE: This curve, based on extensive tests, defines the average performance of this pump for liquids having a viscosity of 70 SSU or less. Actual performance of individual units may differ slightly from the performance indicated on this curve. Pump applications made from the data contained herein are subject to confirmation and acceptance by our Engineering Department at our Indianapolis Office.

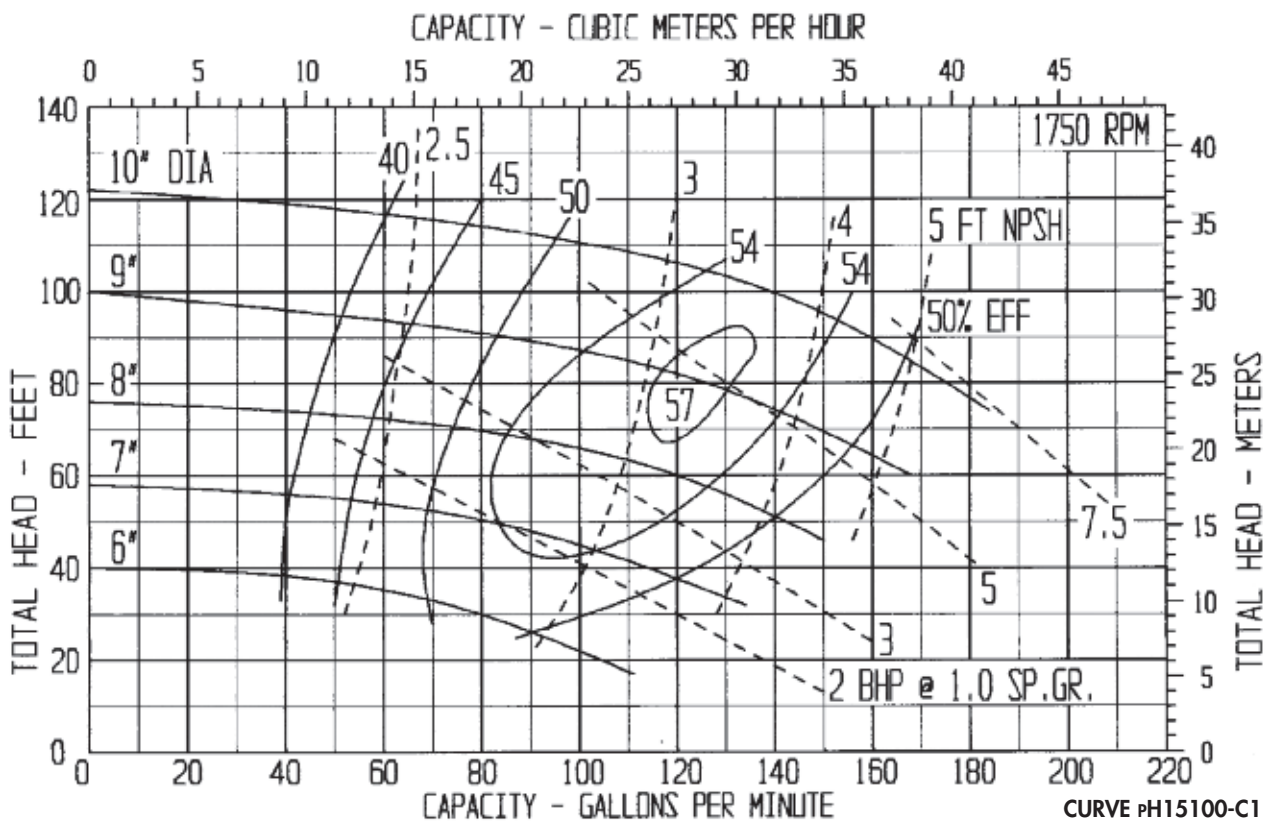
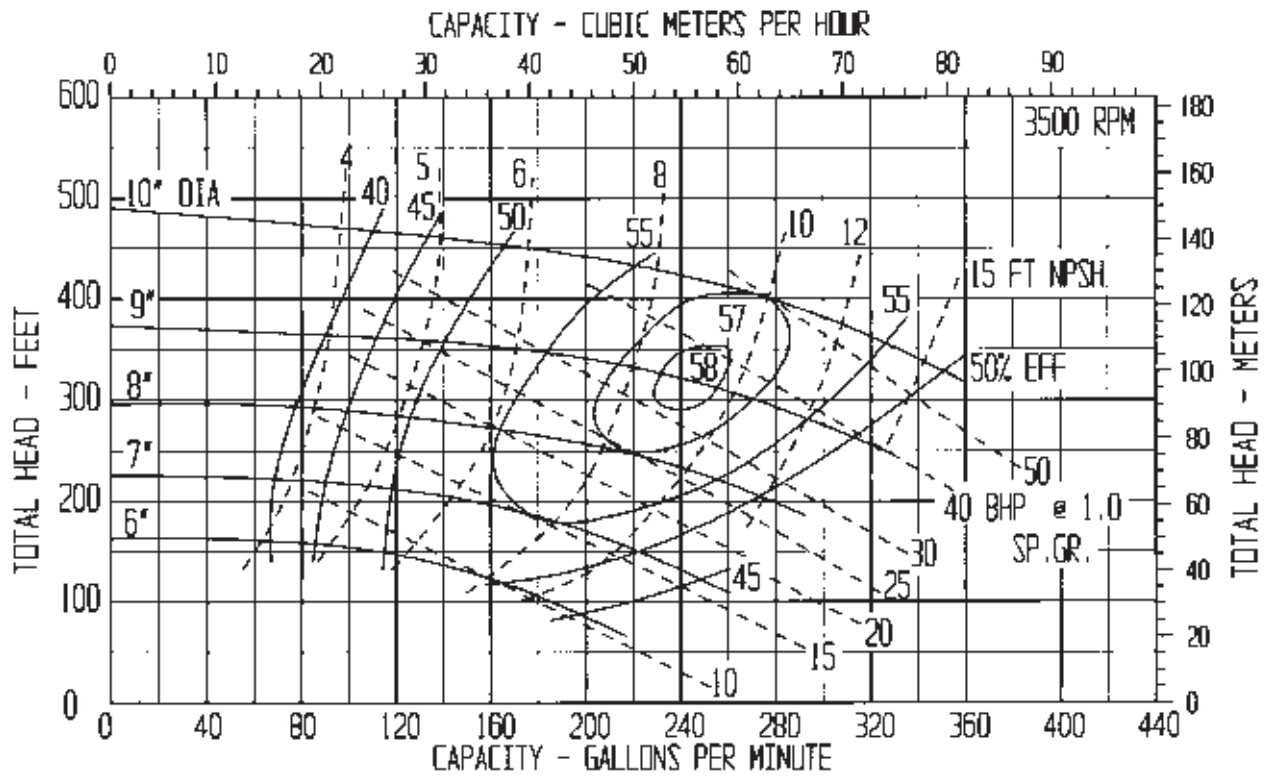

CURVE pH15100-C1

CECO Dean

(317) 293-2930 • E-mail: infohfs@onececo.com

CENTRIFUGAL PUMP PERFORMANCE DATA: CURVE pH15115-A3

PUMP SIZE: 1 1/2" X 3" X 1 1/2"

PUMP TYPE: pH2140

MAXIMUM SOLIDS 7/16" DIAMETER

2" DISCHARGE X 3" SUCTION

PUMP PERFORMANCE: This curve, based on extensive tests, defines the average performance of this pump for liquids having a viscosity of 70 SSU or less. Actual performance of individual units may differ slightly from the performance indicated on this curve. Pump applications made from the data contained herein are subject to confirmation and acceptance by our Engineering Department at our Indianapolis Office.

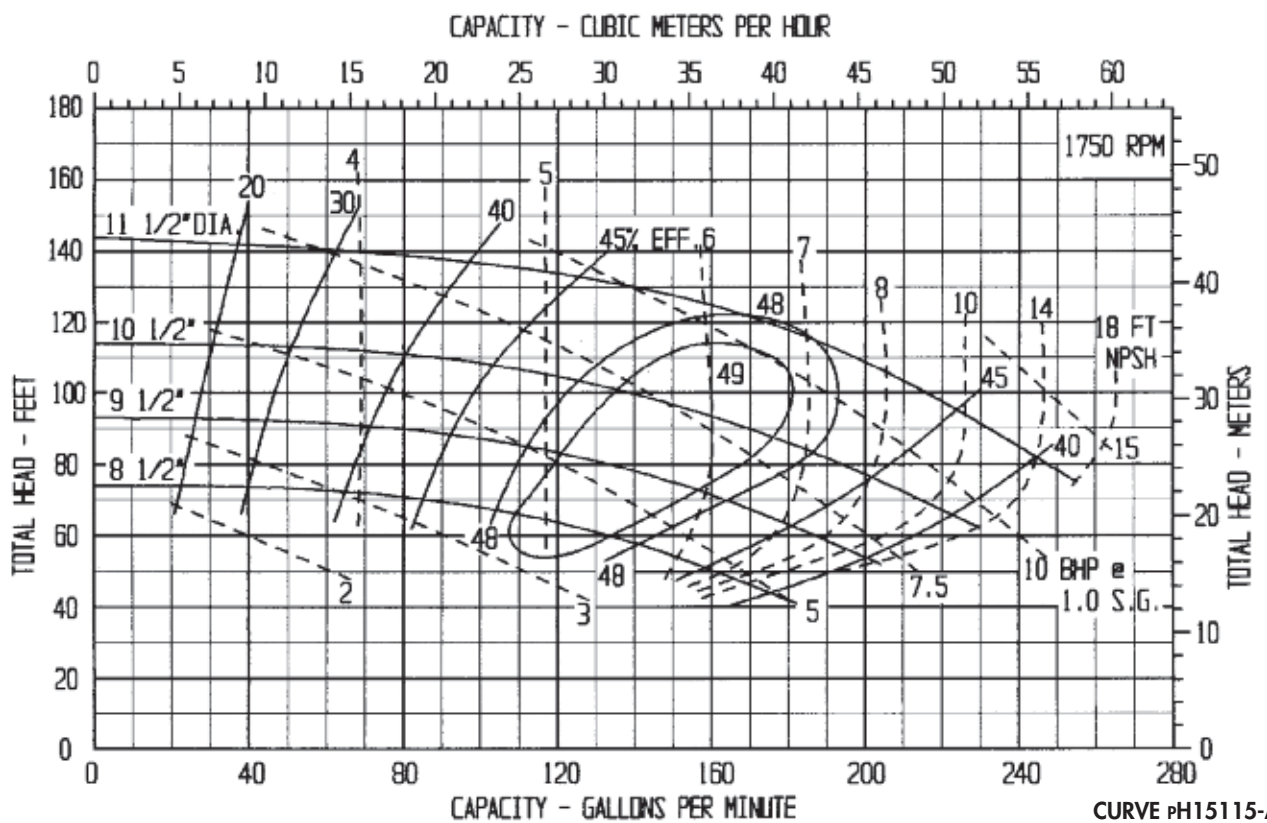
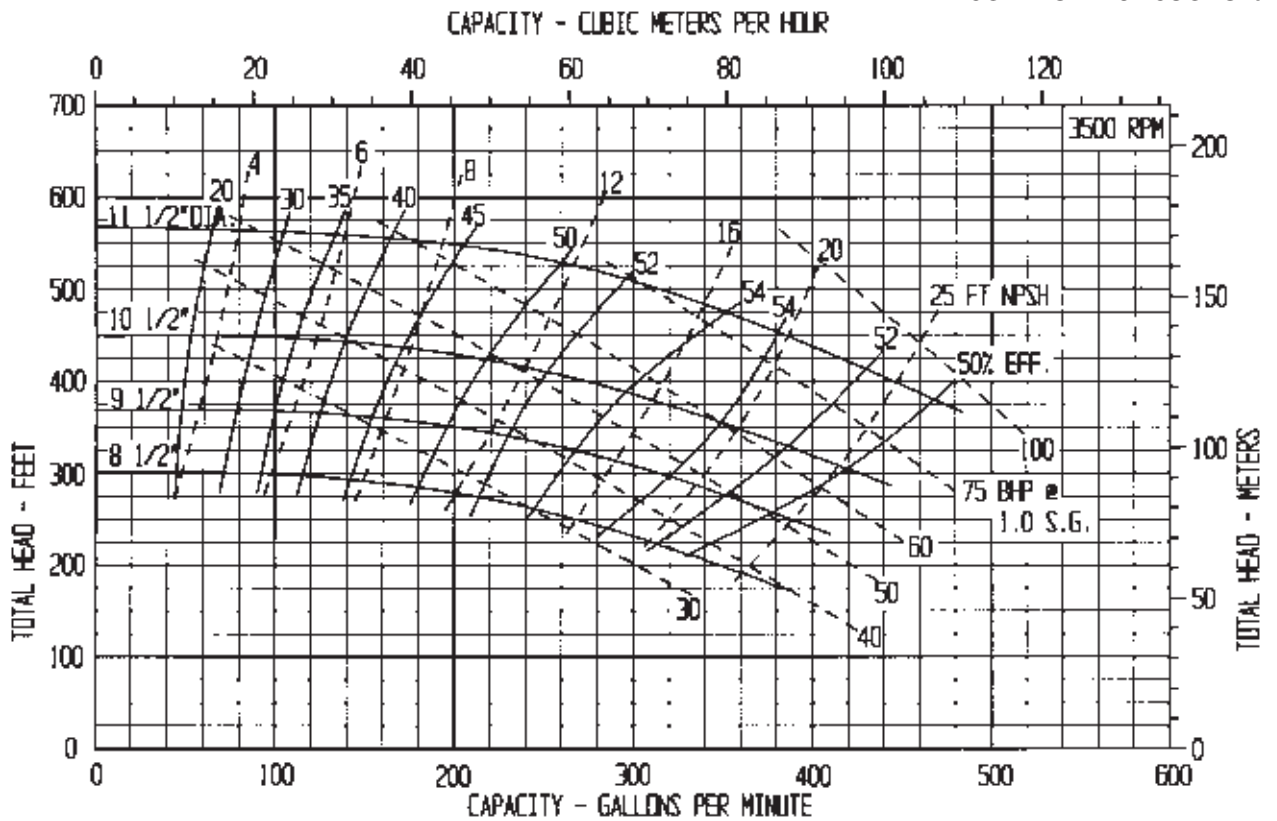

CURVE pH15115-A3

CECO Dean

(317) 293-2930 • E-mail: infohfs@onececo.com

CENTRIFUGAL PUMP PERFORMANCE DATA: CURVE pH15135-A1

PUMP SIZE: 1 1/2" X 3" X 13 1/2"

PUMP TYPE: PH2140

MAXIMUM SOLIDS 3/8" DIAMETER

1 1/2" DISCHARGE X 3" SUCTION

PUMP PERFORMANCE: This curve, based on extensive tests, defines the average performance of this pump for liquids having a viscosity of 70 SSU or less. Actual performance of individual units may differ slightly from the performance indicated on this curve. Pump applications made from the data contained herein are subject to confirmation and acceptance by our Engineering Department at our Indianapolis Office.

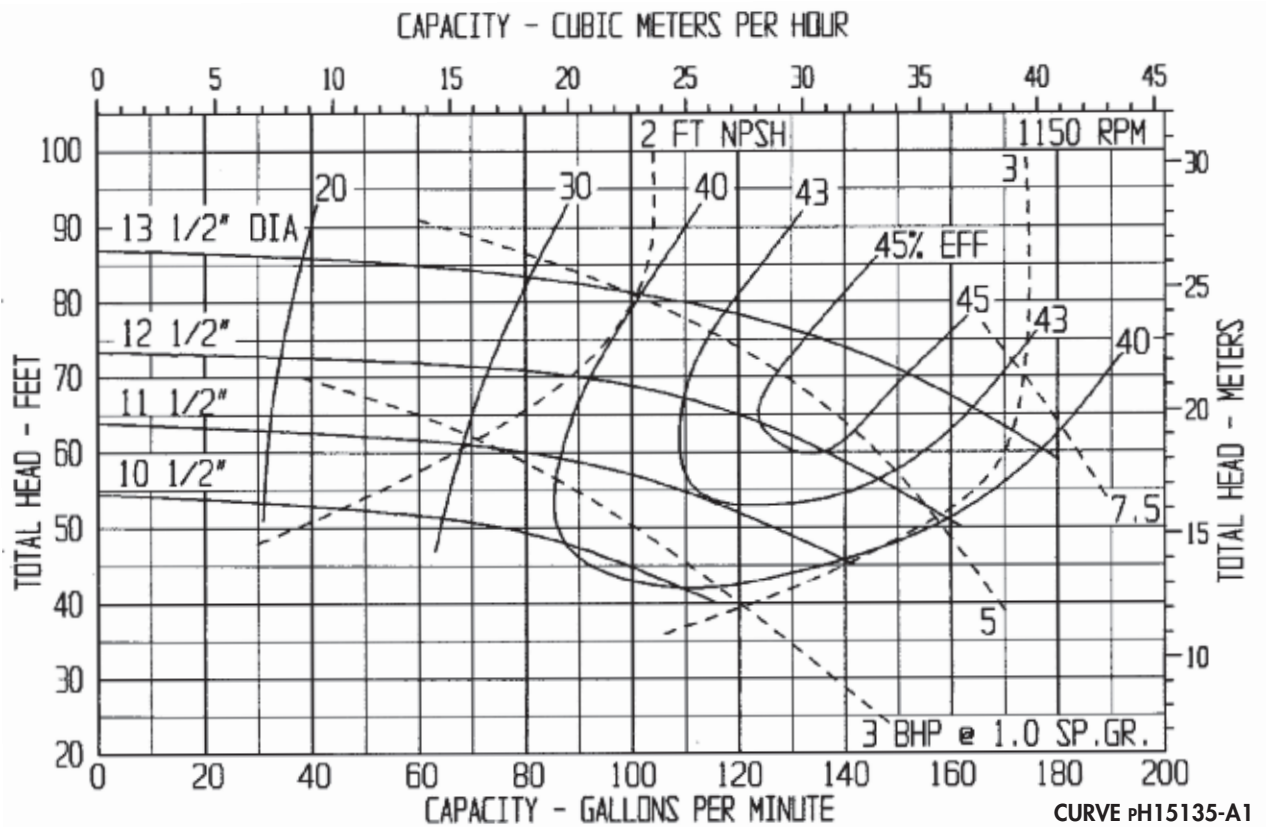
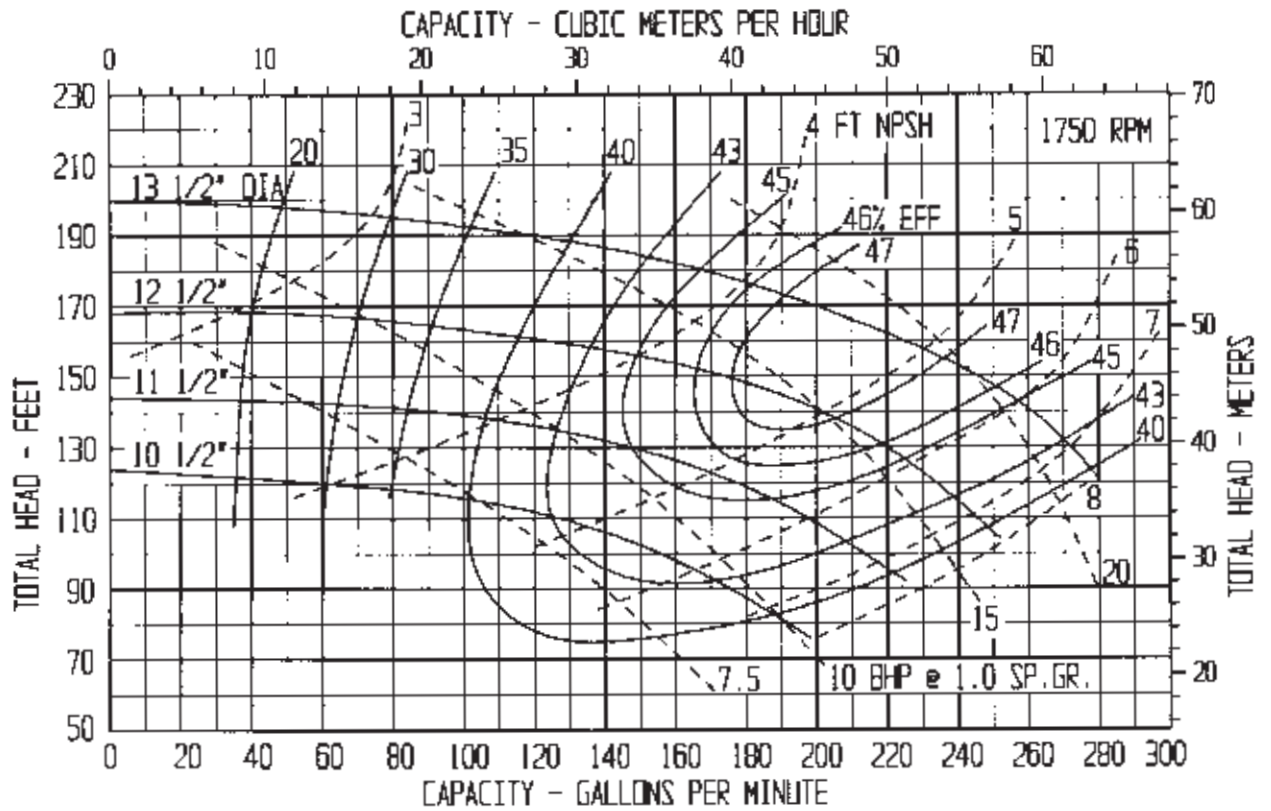

CURVE pH15135-A1

CECO Dean

(317) 293-2930 • E-mail: infofhs@onececo.com

CENTRIFUGAL PUMP PERFORMANCE DATA: CURVE pH15135-B1

PUMP SIZE: 1 1/2" X 3" X 13 1/2"

PUMP TYPE: pH3170

MAXIMUM SOLIDS 3/8" DIAMETER

1 1/2" DISCHARGE X 3" SUCTION

PUMP PERFORMANCE: This curve, based on extensive tests, defines the average performance of this pump for liquids having a viscosity of 70 SSU or less. Actual performance of individual units may differ slightly from the performance indicated on this curve. Pump applications made from the data contained herein are subject to confirmation and acceptance by our Engineering Department at our Indianapolis Office.

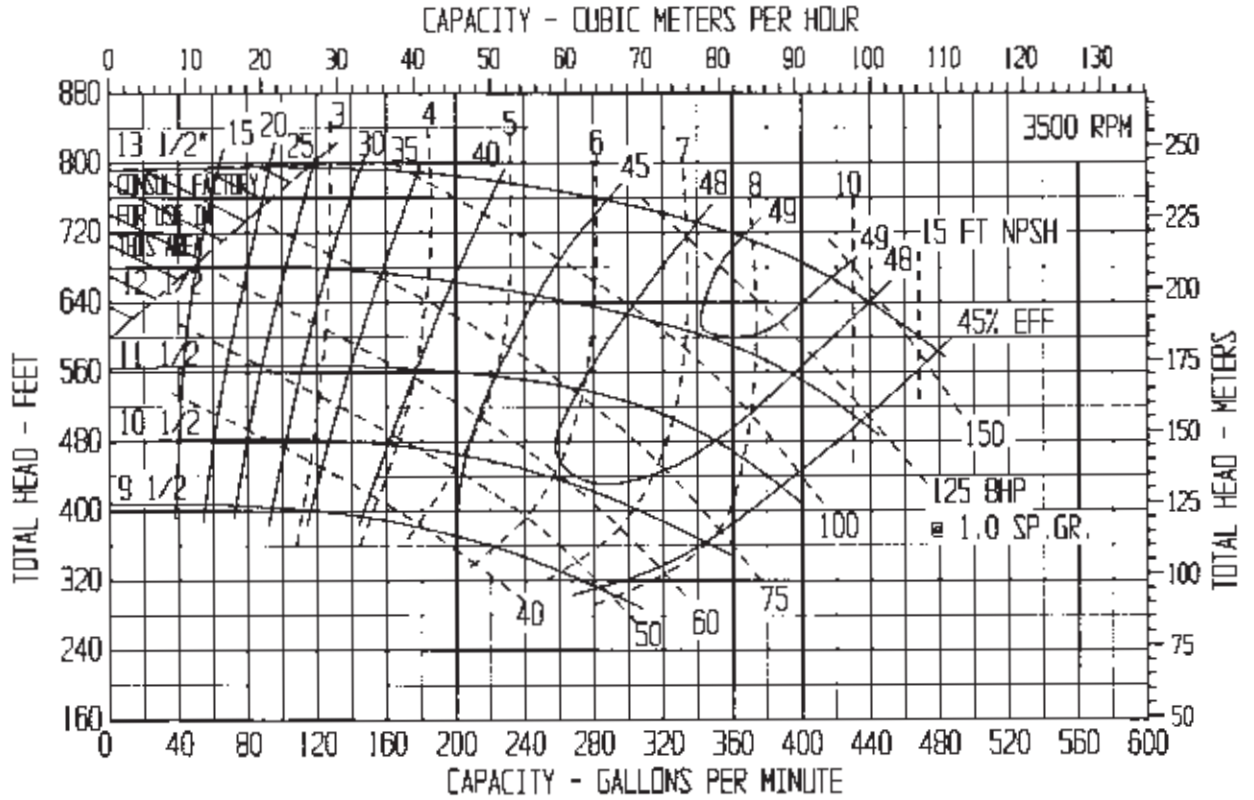

PUMP PERFORMANCE: This curve, based on extensive tests, defines the average performance of this pump for liquids having a viscosity of 70 SSU or less. Actual performance of individual units may differ slightly from the performance indicated on this curve. Pump applications made from the data contained herein are subject to confirmation and acceptance by our Engineering Department at our Indianapolis Office.

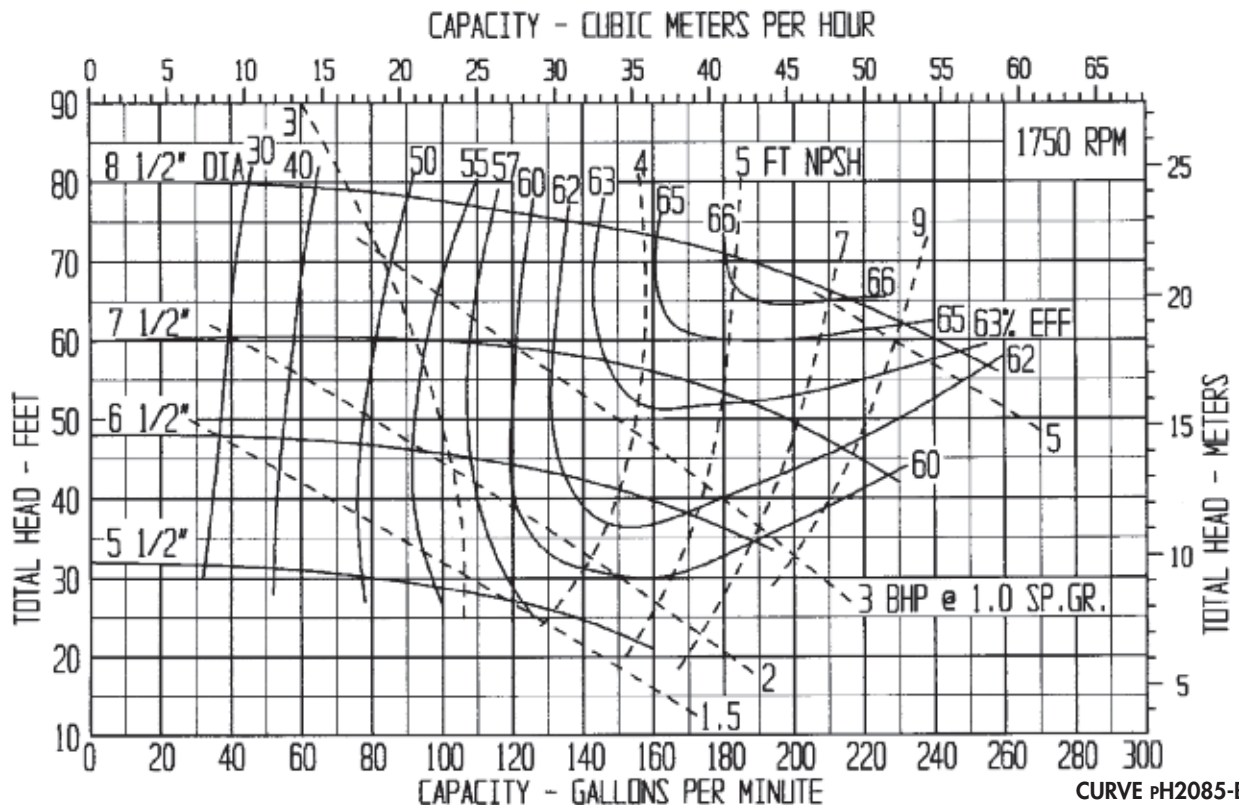
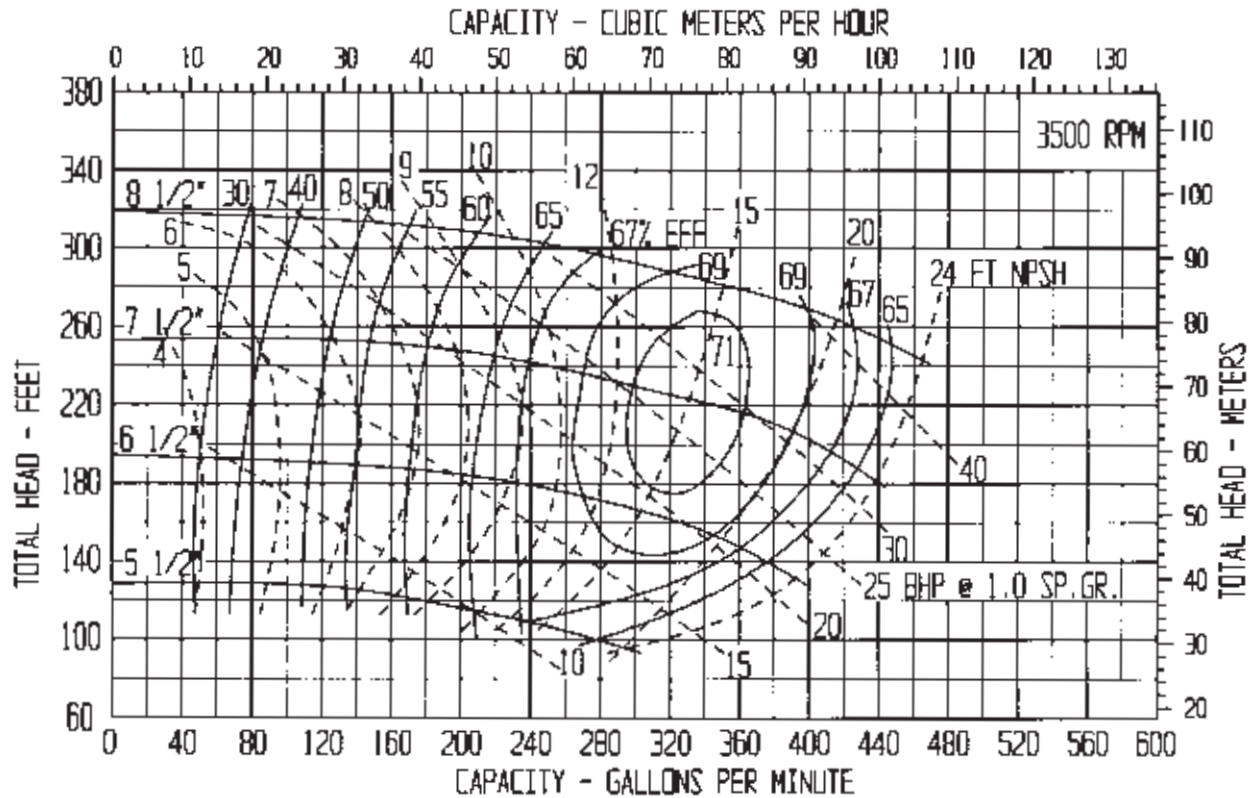

CURVE PH2085-B1

PUMP PERFORMANCE: This curve, based on extensive tests, defines the average performance of this pump for liquids having a viscosity of 70 SSU or less. Actual performance of individual units may differ slightly from the performance indicated on this curve. Pump applications made from the data contained herein are subject to confirmation and acceptance by our Engineering Department at our Indianapolis Office.

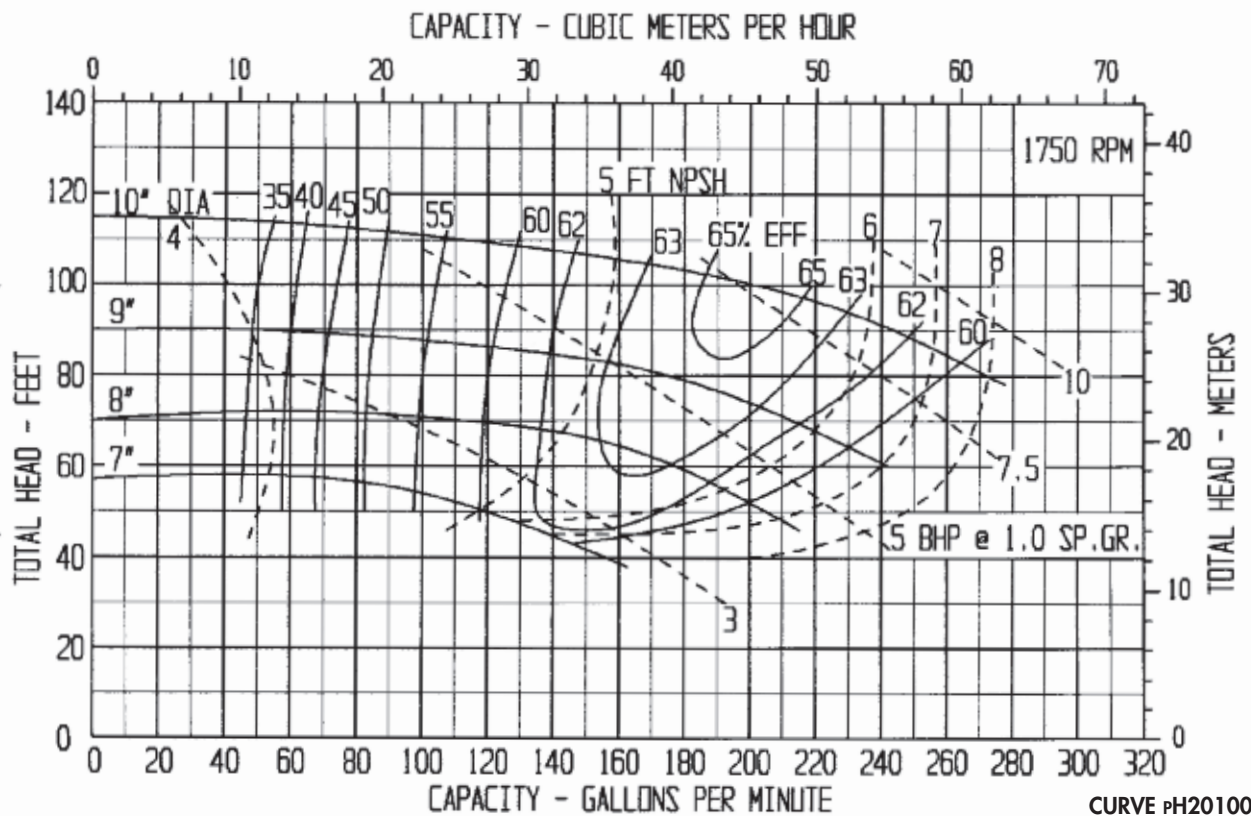
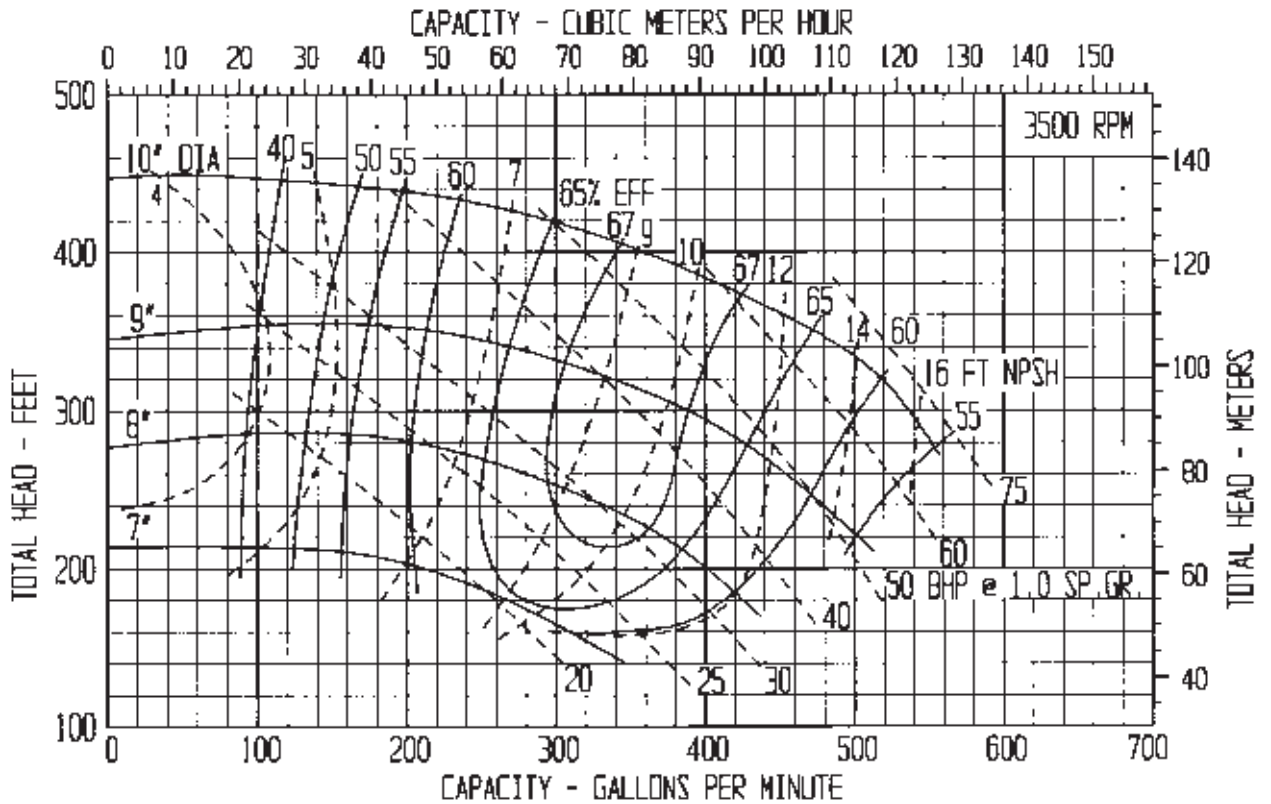

PUMP PERFORMANCE: This curve, based on extensive tests, defines the average performance of this pump for liquids having a viscosity of 70 SSU or less. Actual performance of individual units may differ slightly from the performance indicated on this curve. Pump applications made from the data contained herein are subject to confirmation and acceptance by our Engineering Department at our Indianapolis Office.

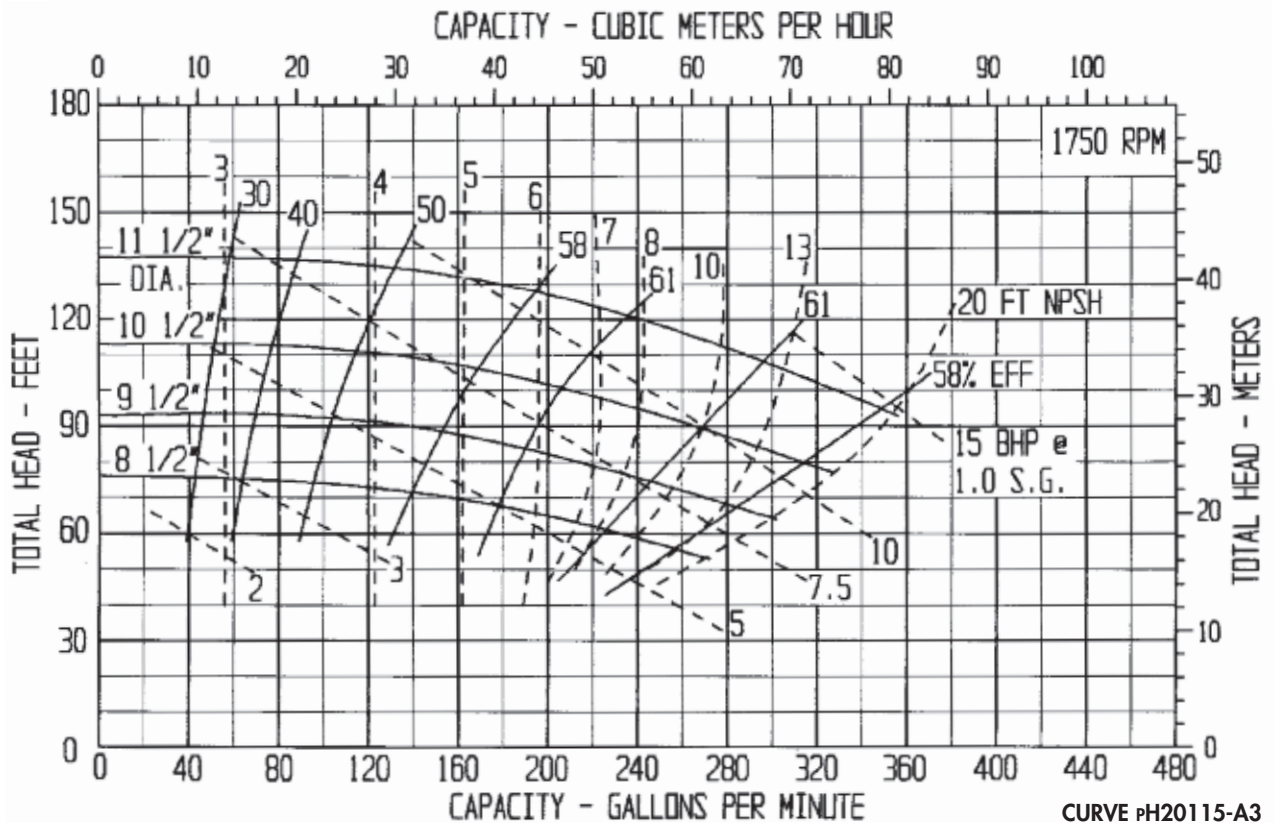
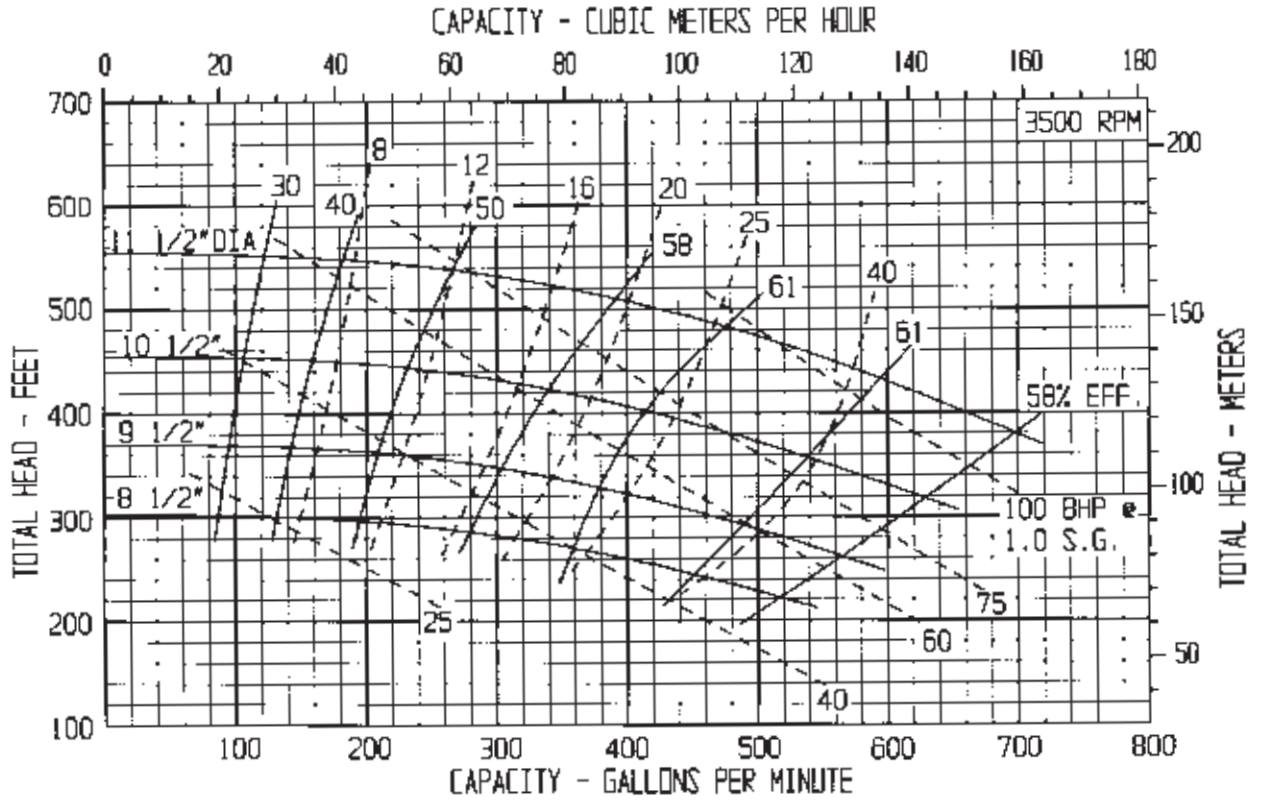

CECO Dean

(317) 293-2930 • E-mail: infohfs@onececo.com

CENTRIFUGAL PUMP PERFORMANCE DATA: CURVE pH20135-A1

PUMP SIZE: 2" X 3" X 13 1/2"

PUMP TYPE: pH2140

MAXIMUM SOLIDS 3/8" DIAMETER

2" DISCHARGE X 3" SUCTION

PUMP PERFORMANCE: This curve, based on extensive tests, defines the average performance of this pump for liquids having a viscosity of 70 SSU or less. Actual performance of individual units may differ slightly from the performance indicated on this curve. Pump applications made from the data contained herein are subject to confirmation and acceptance by our Engineering Department at our Indianapolis Office.

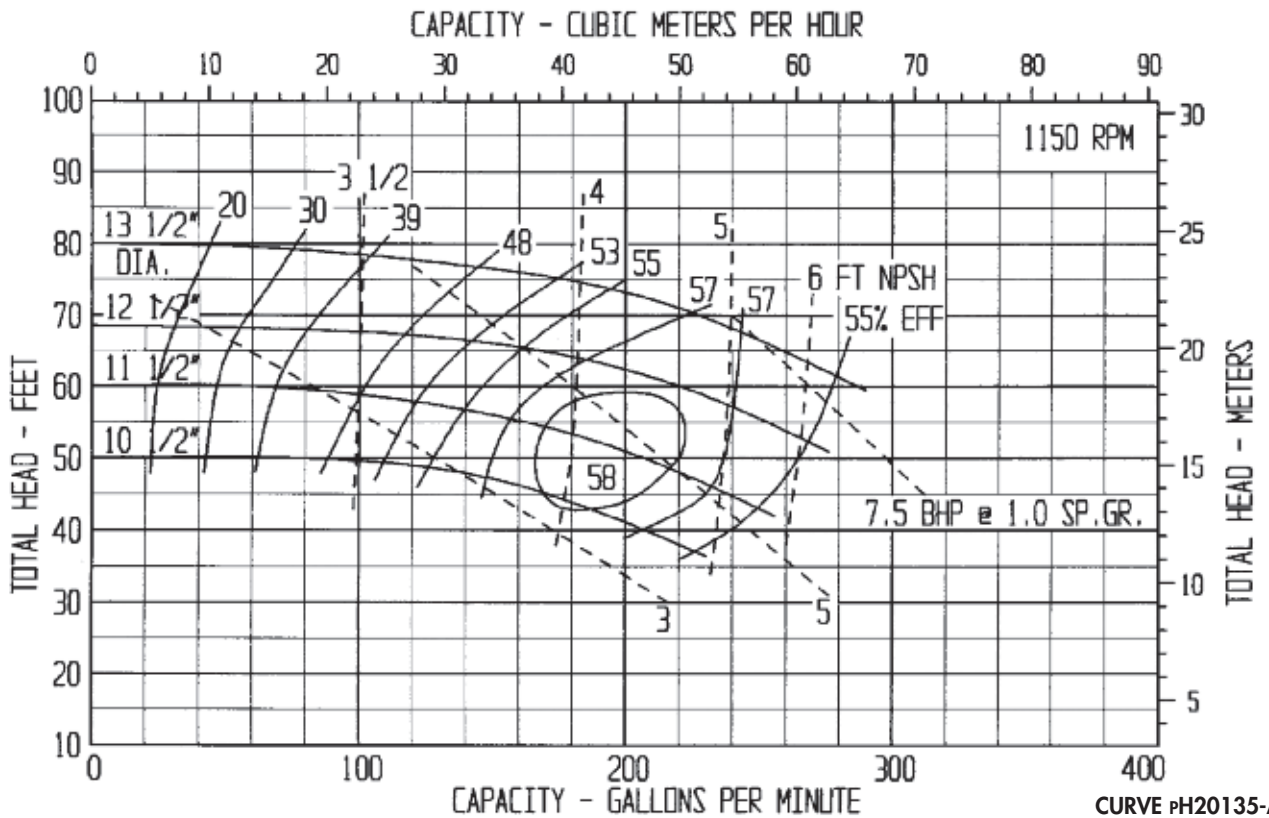
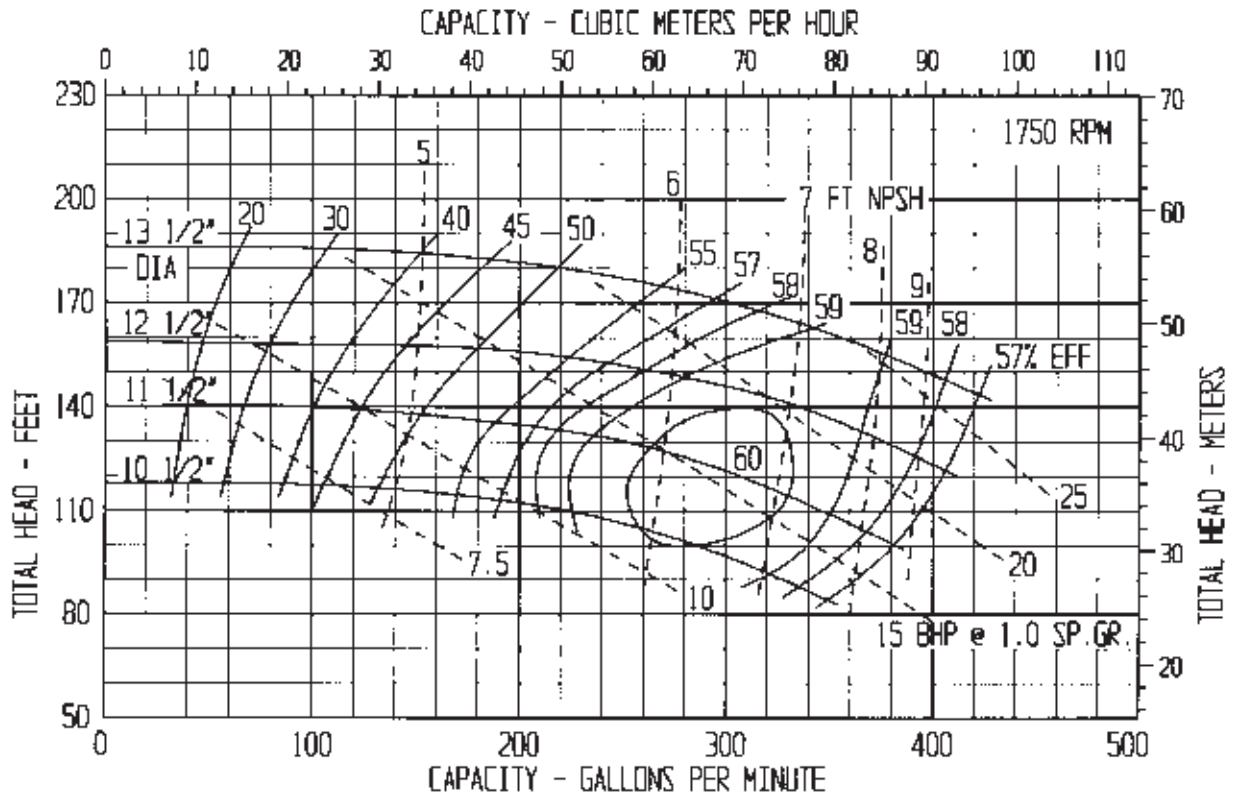

CURVE pH20135-A1

PUMP PERFORMANCE: This curve, based on extensive tests, defines the average performance of this pump for liquids having a viscosity of 70 SSU or less. Actual performance of individual units may differ slightly from the performance indicated on this curve. Pump applications made from the data contained herein are subject to confirmation and acceptance by our Engineering Department at our Indianapolis Office.

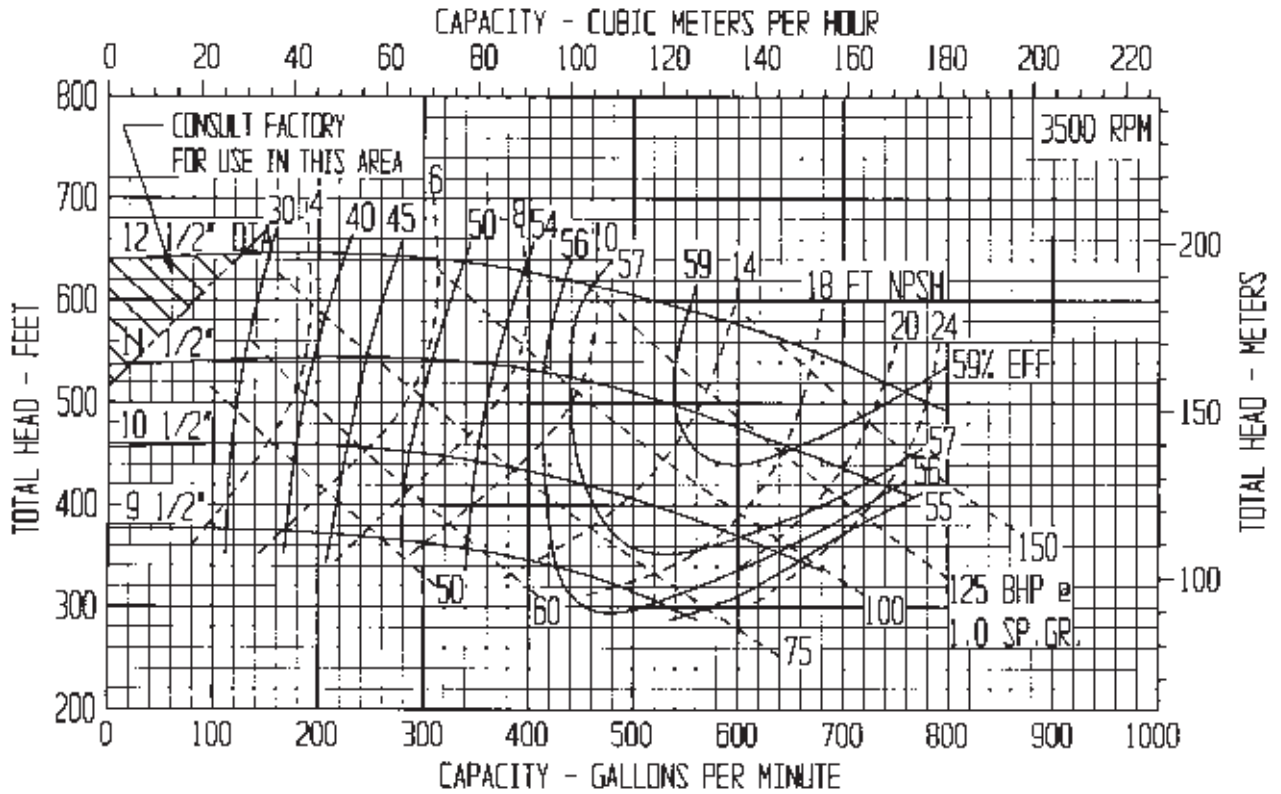

CECO Dean

(317) 293-2930 • E-mail: infohfs@onececo.com

CENTRIFUGAL PUMP PERFORMANCE DATA: CURVE pH3085-A2

PUMP SIZE: 3" X 4" X 8 1/2" #1

PUMP TYPE: pH2140

MAXIMUM SOLIDS 1 1/16" DIAMETER

3" DISCHARGE X 4" SUCTION

PUMP PERFORMANCE: This curve, based on extensive tests, defines the average performance of this pump for liquids having a viscosity of 70 SSU or less. Actual performance of individual units may differ slightly from the performance indicated on this curve. Pump applications made from the data contained herein are subject to confirmation and acceptance by our Engineering Department at our Indianapolis Office.

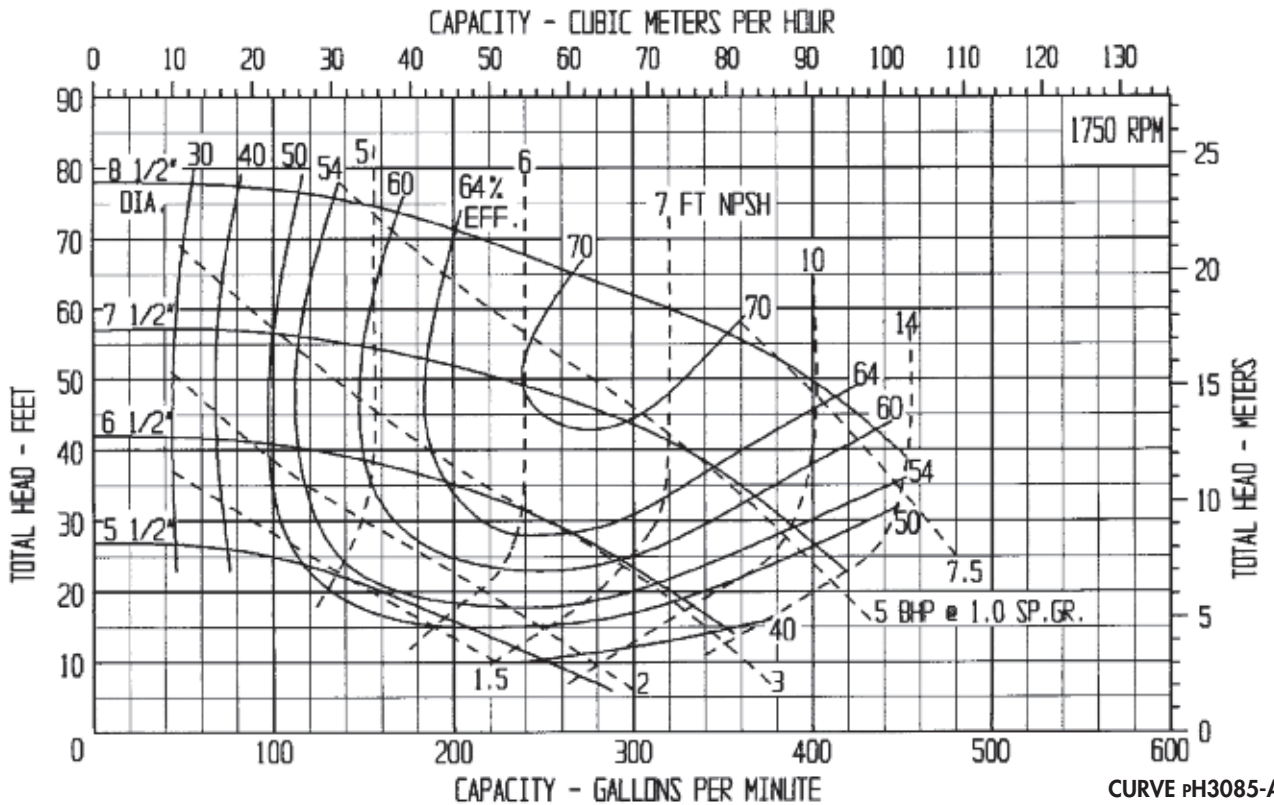
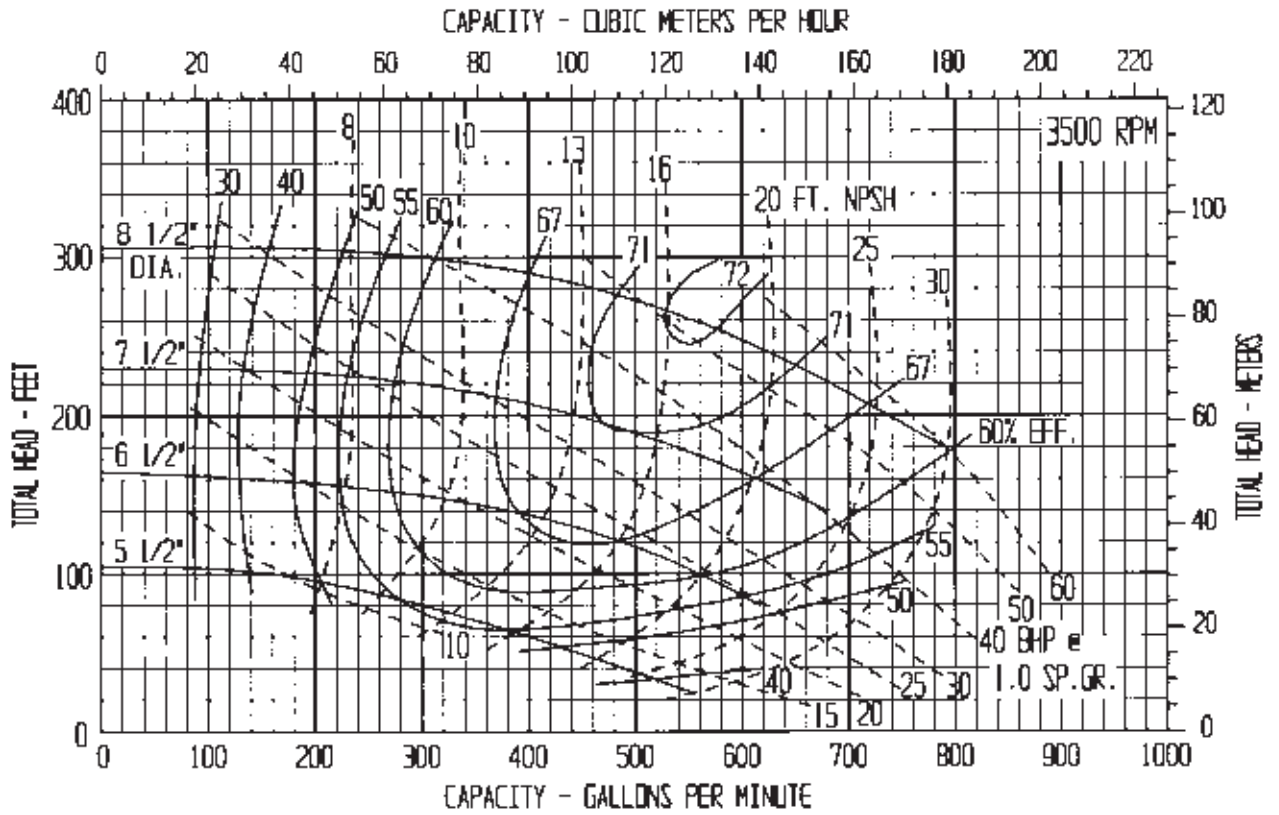

CURVE pH3085-A2

PUMP PERFORMANCE: This curve, based on extensive tests, defines the average performance of this pump for liquids having a viscosity of 70 SSU or less. Actual performance of individual units may differ slightly from the performance indicated on this curve. Pump applications made from the data contained herein are subject to confirmation and acceptance by our Engineering Department at our Indianapolis Office.

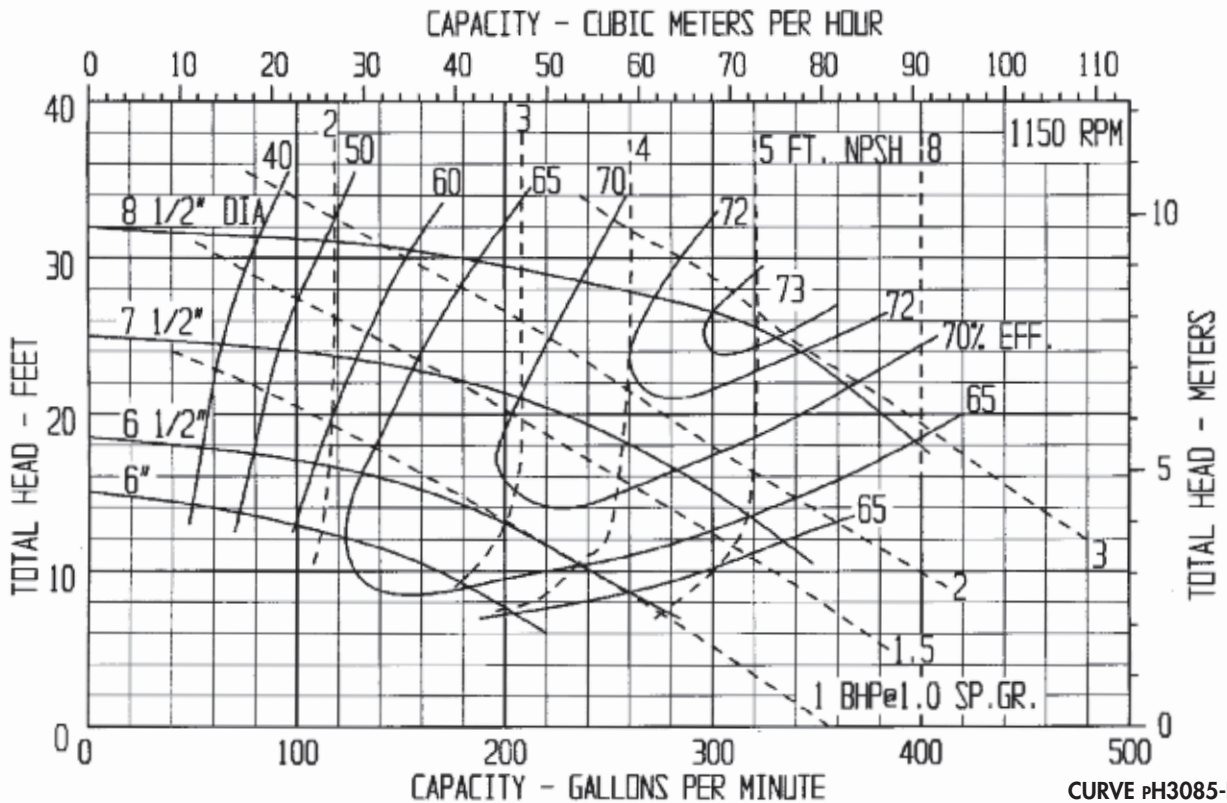
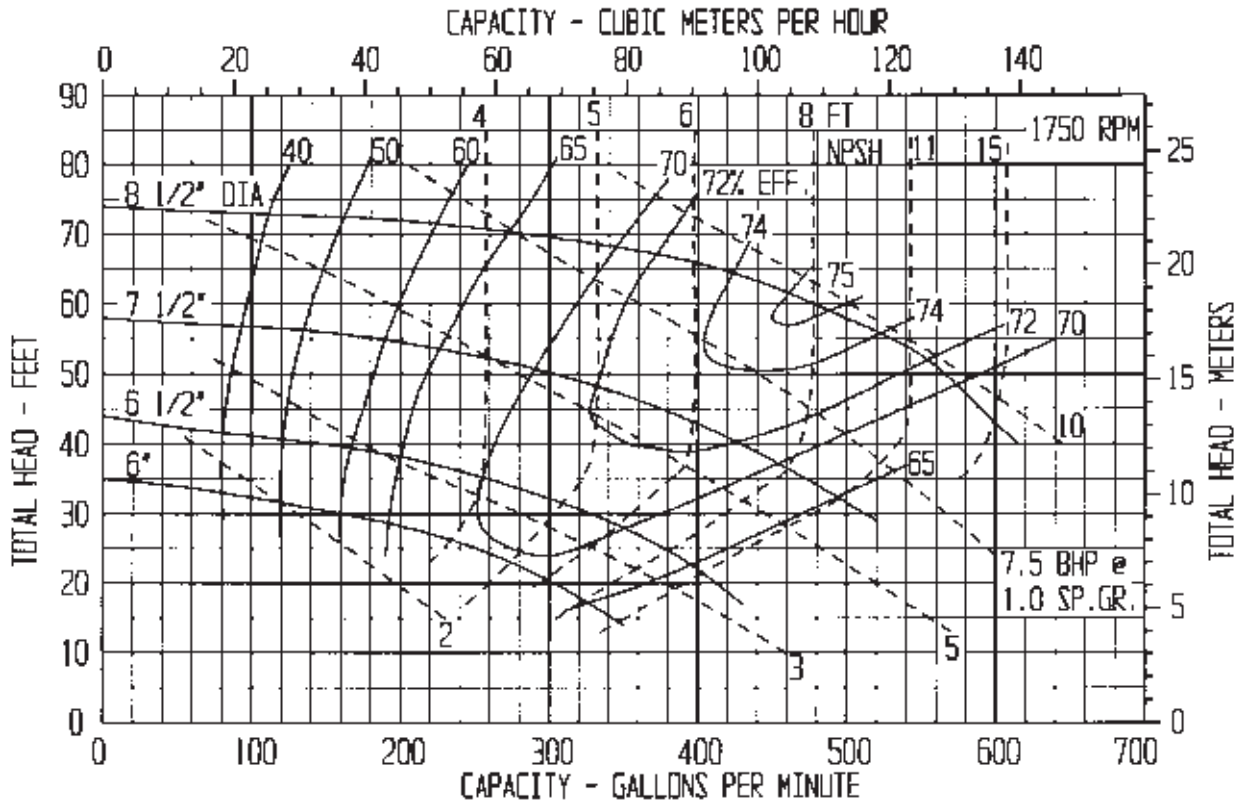

CURVE PH3085-B2

PUMP PERFORMANCE: This curve, based on extensive tests, defines the average performance of this pump for liquids having a viscosity of 70 SSU or less. Actual performance of individual units may differ slightly from the performance indicated on this curve. Pump applications made from the data contained herein are subject to confirmation and acceptance by our Engineering Department at our Indianapolis Office.

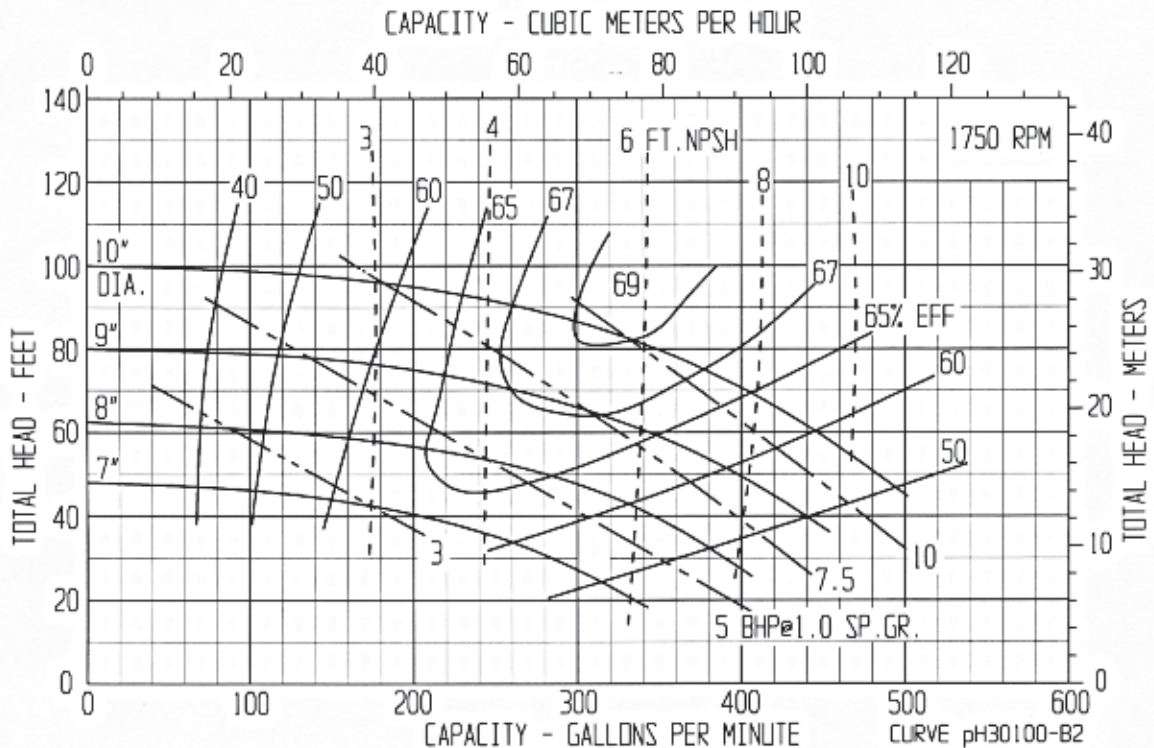
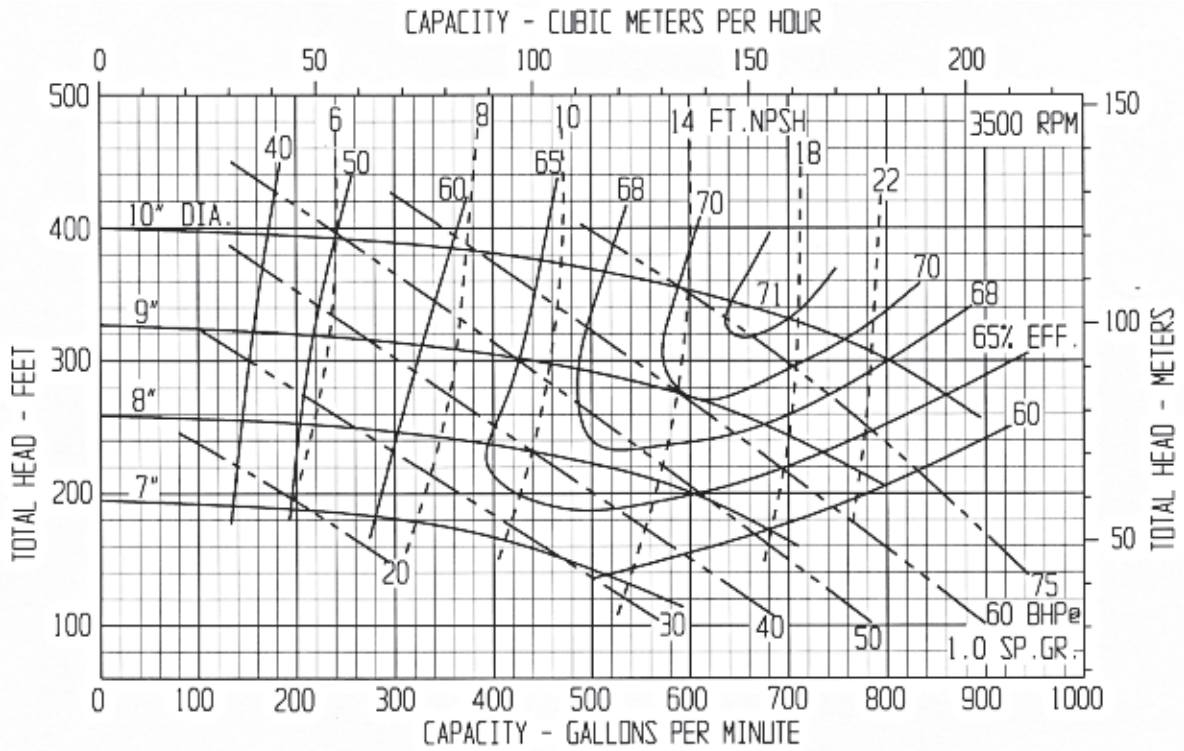

PUMP PERFORMANCE: This curve, based on extensive tests, defines the average performance of this pump for liquids having a viscosity of 70 SSU or less. Actual performance of individual units may differ slightly from the performance indicated on this curve. Pump applications made from the data contained herein are subject to confirmation and acceptance by our Engineering Department at our Indianapolis Office.

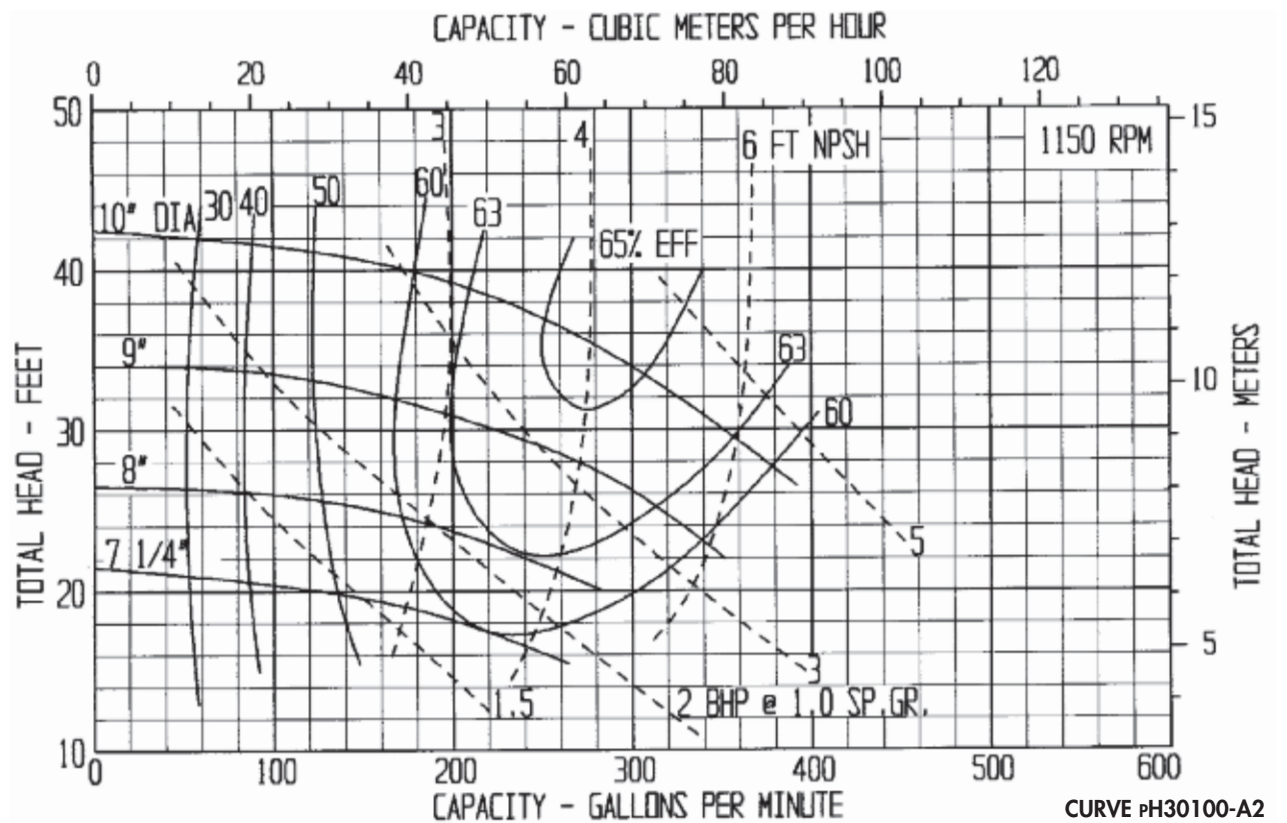
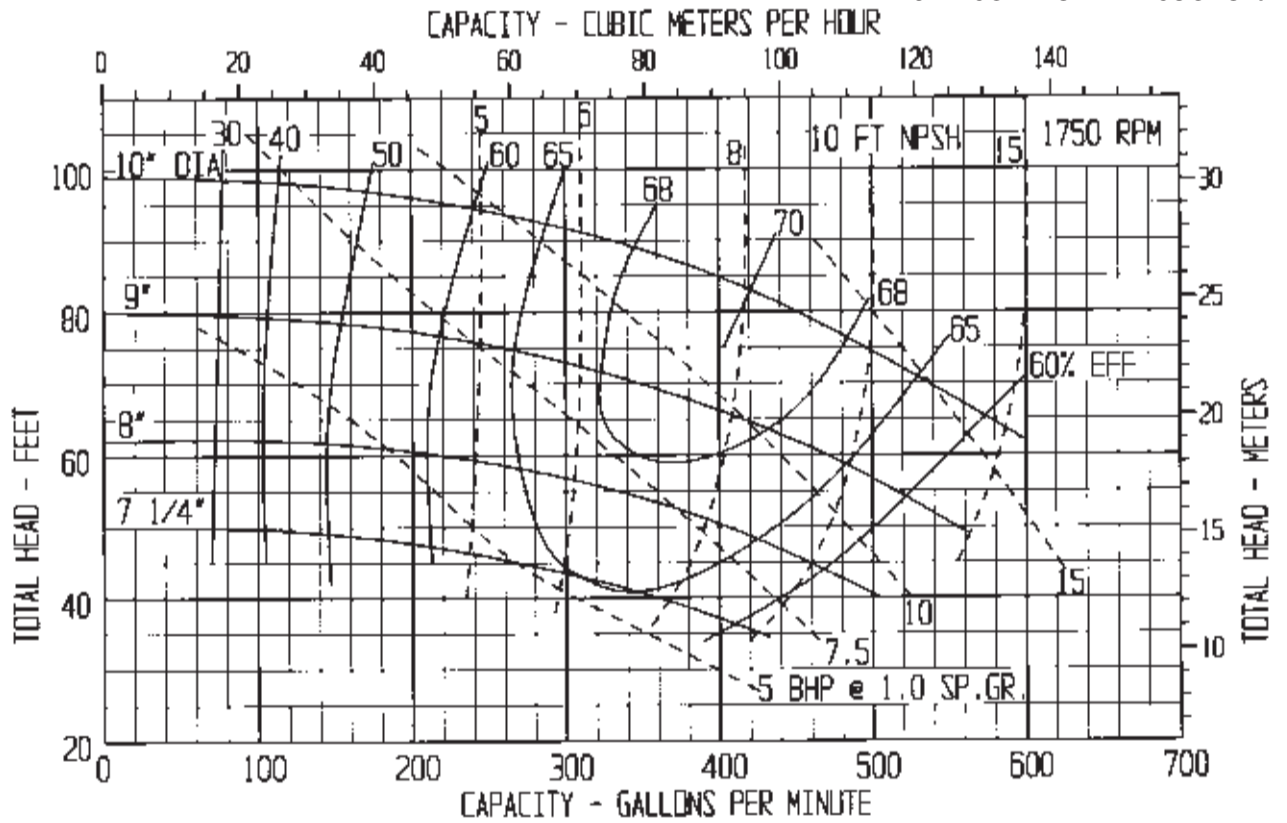

CURVE pH30100-A2

CECO Dean

(317) 293-2930 • E-mail: infohfs@onececo.com

CENTRIFUGAL PUMP PERFORMANCE DATA: CURVE pH30115-B1

PUMP SIZE: 3" X 4" X 11 1/2"

PUMP TYPE: pH2140

MAXIMUM SOLIDS 7/16" DIAMETER

3" DISCHARGE X 4" SUCTION

PUMP PERFORMANCE: This curve, based on extensive tests, defines the average performance of this pump for liquids having a viscosity of 70 SSU or less. Actual performance of individual units may differ slightly from the performance indicated on this curve. Pump applications made from the data contained herein are subject to confirmation and acceptance by our Engineering Department at our Indianapolis Office.

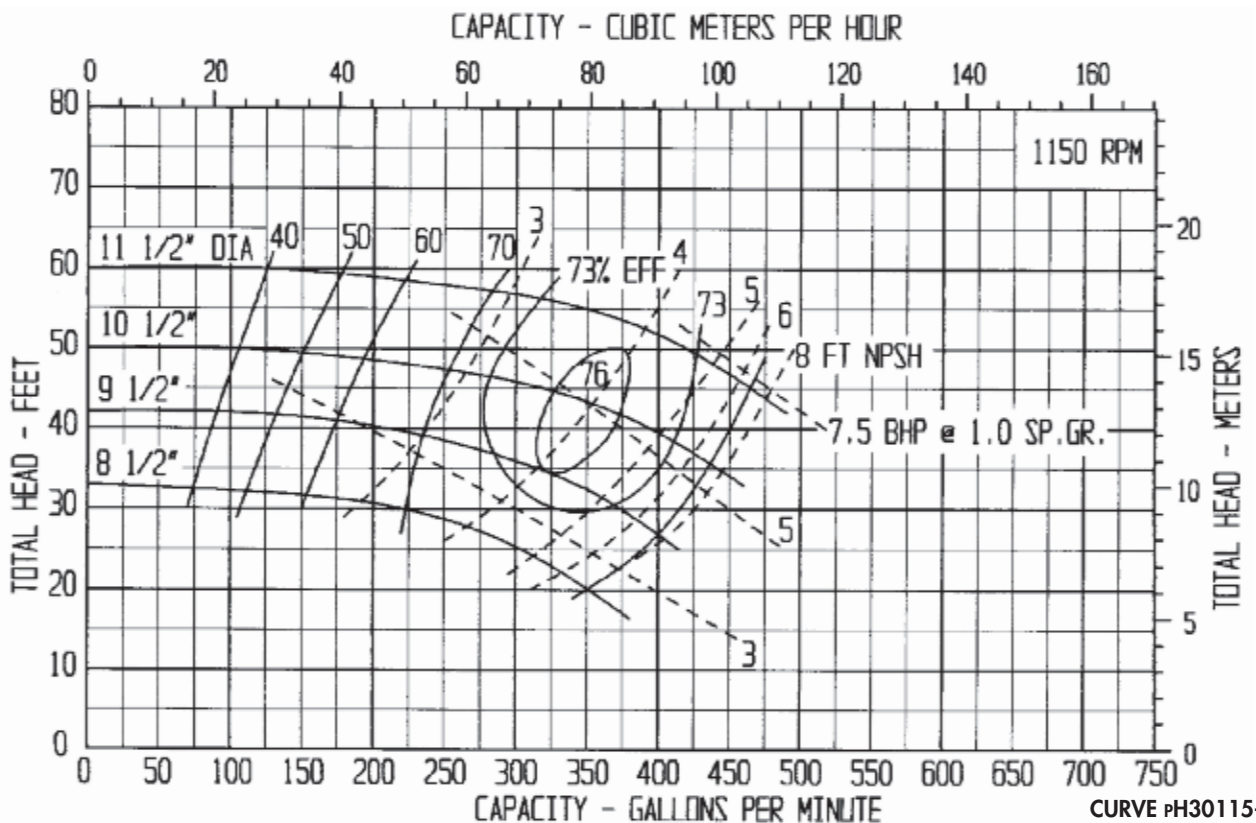
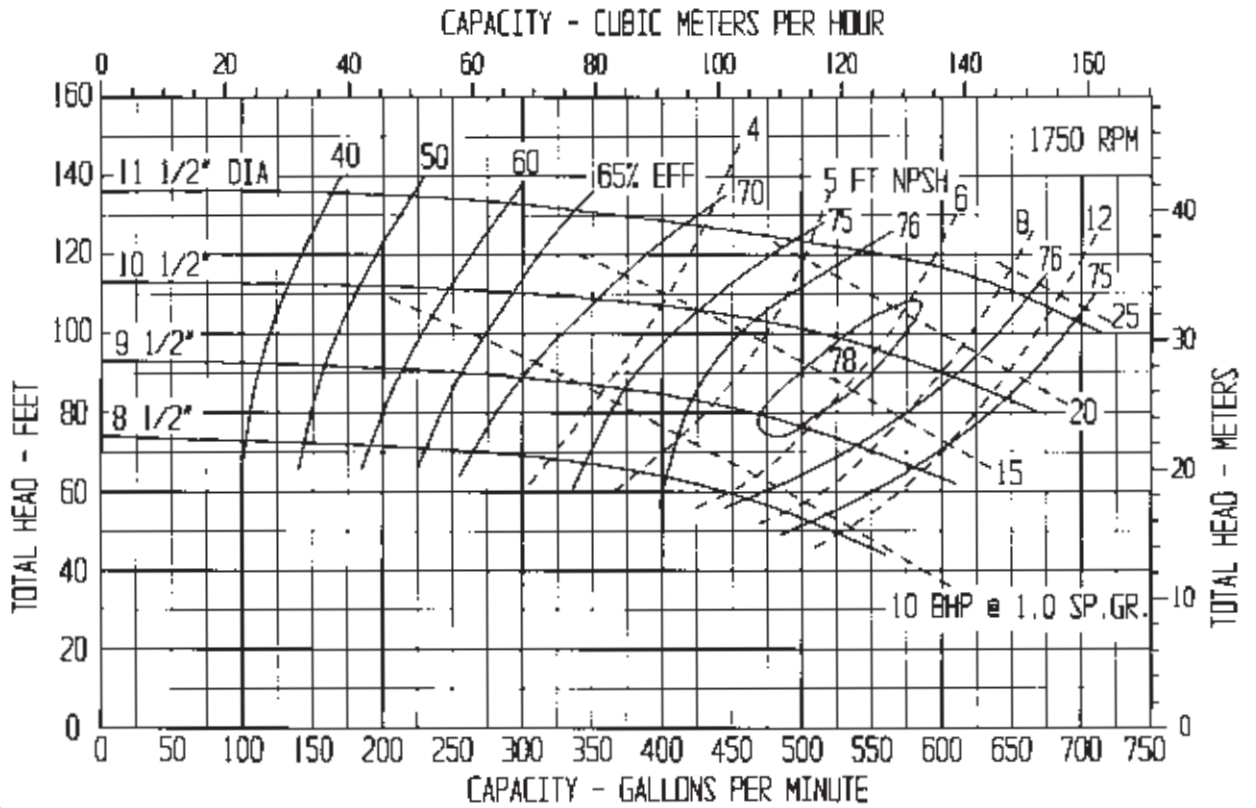

CURVE pH30115-B1

PUMP PERFORMANCE: This curve, based on extensive tests, defines the average performance of this pump for liquids having a viscosity of 70 SSU or less. Actual performance of individual units may differ slightly from the performance indicated on this curve. Pump applications made from the data contained herein are subject to confirmation and acceptance by our Engineering Department at our Indianapolis Office.

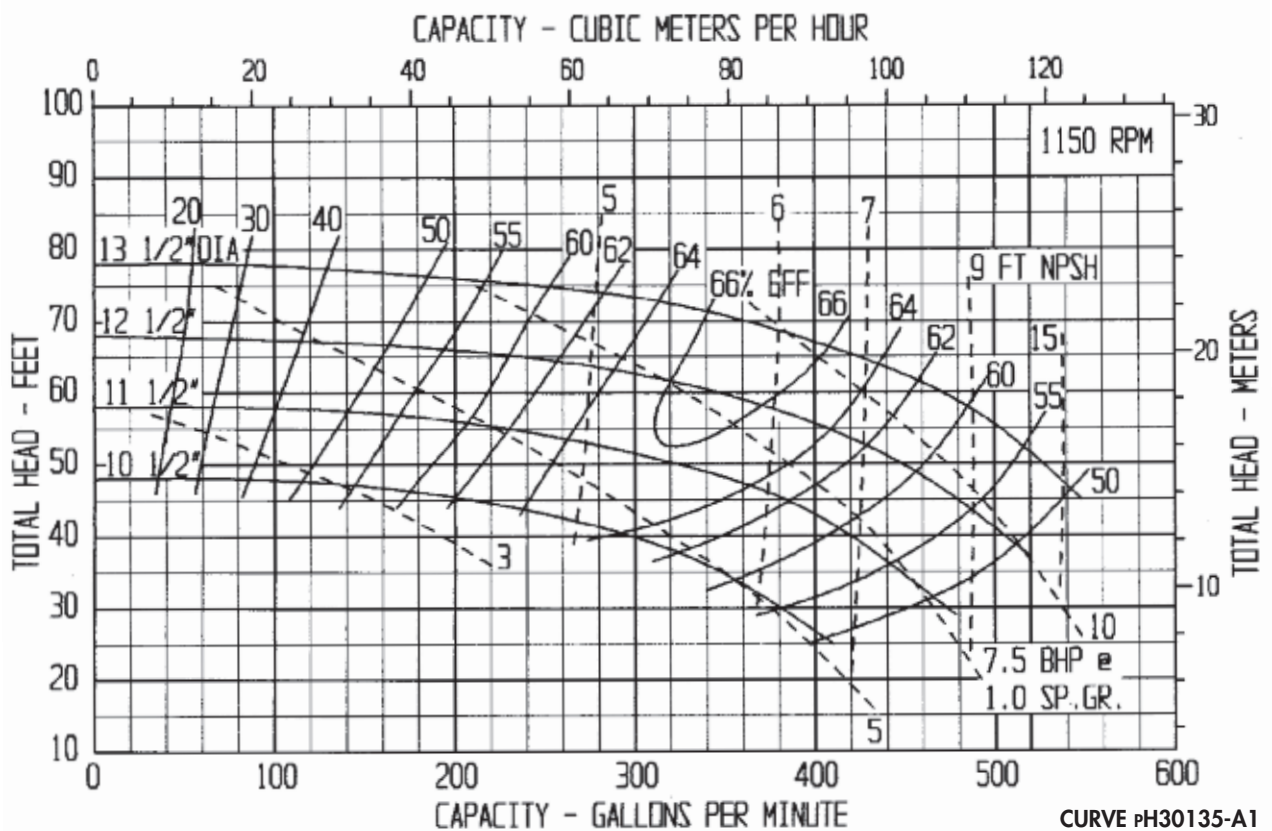
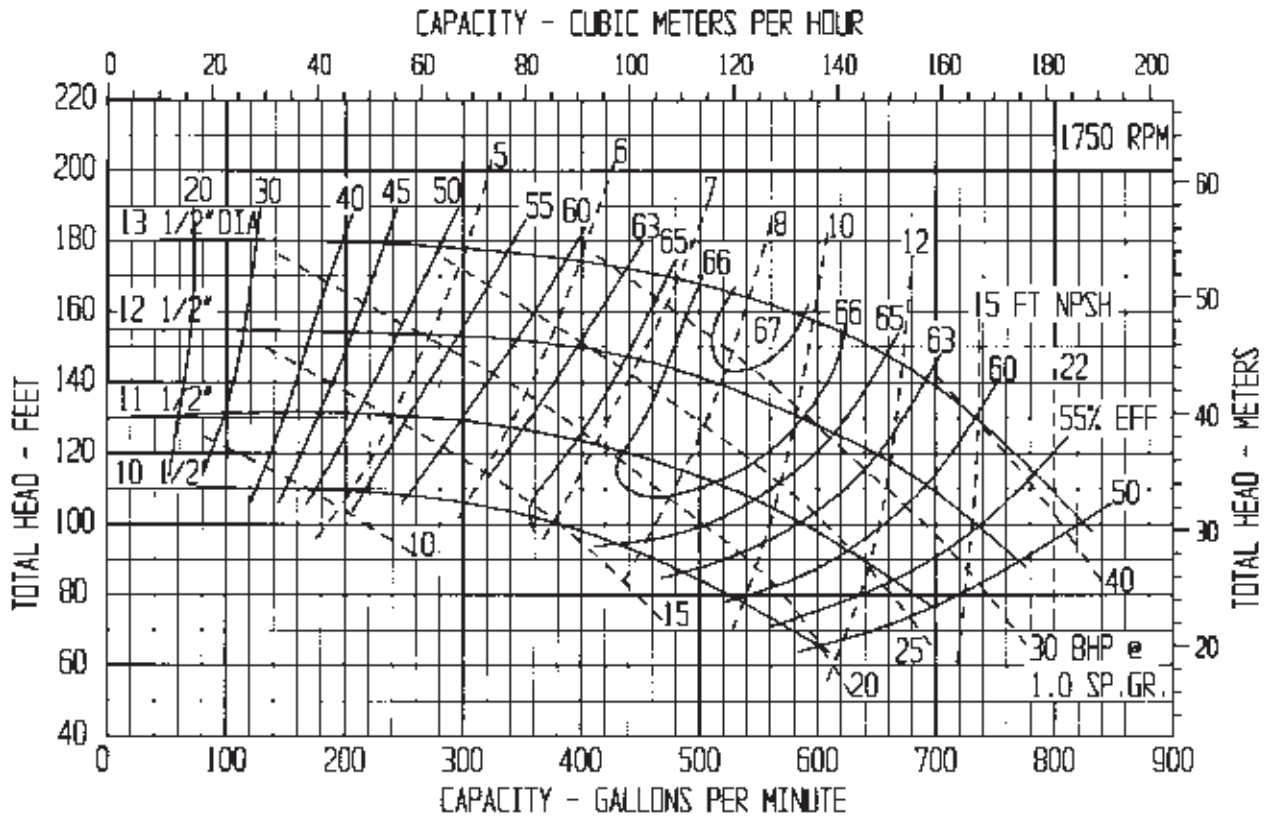

CURVE pH30135-A1

CECO Dean

(317) 293-2930 • E-mail: infohfs@onececo.com

CENTRIFUGAL PUMP PERFORMANCE DATA: CURVE pH30135-B1

PUMP SIZE: 3" X 4" X 13 1/2"

PUMP TYPE: pH3170

MAXIMUM SOLIDS 3/8" DIAMETER

3" DISCHARGE X 4" SUCTION

PUMP PERFORMANCE: This curve, based on extensive tests, defines the average performance of this pump for liquids having a viscosity of 70 SSU or less. Actual performance of individual units may differ slightly from the performance indicated on this curve. Pump applications made from the data contained herein are subject to confirmation and acceptance by our Engineering Department at our Indianapolis Office.

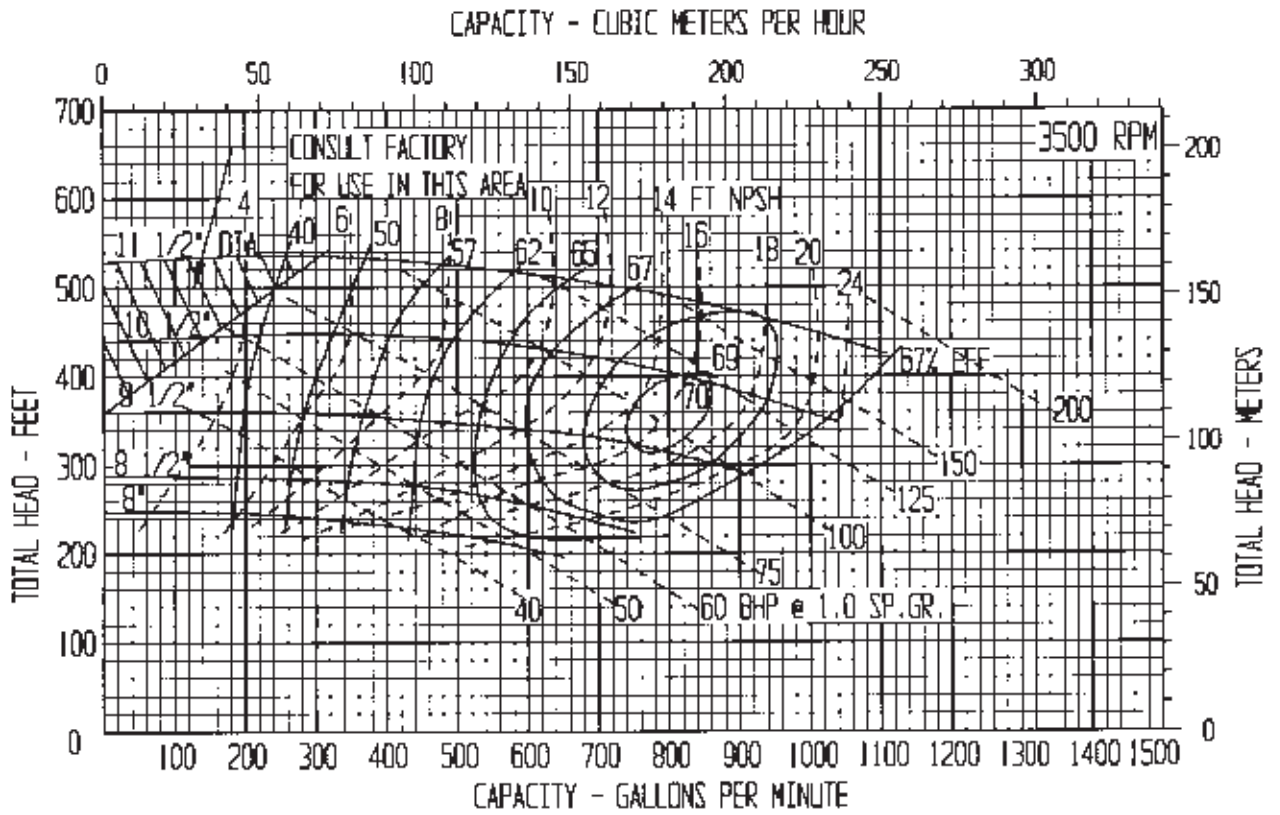

PUMP PERFORMANCE: This curve, based on extensive tests, defines the average performance of this pump for liquids having a viscosity of 70 SSU or less. Actual performance of individual units may differ slightly from the performance indicated on this curve. Pump applications made from the data contained herein are subject to confirmation and acceptance by our Engineering Department at our Indianapolis Office.

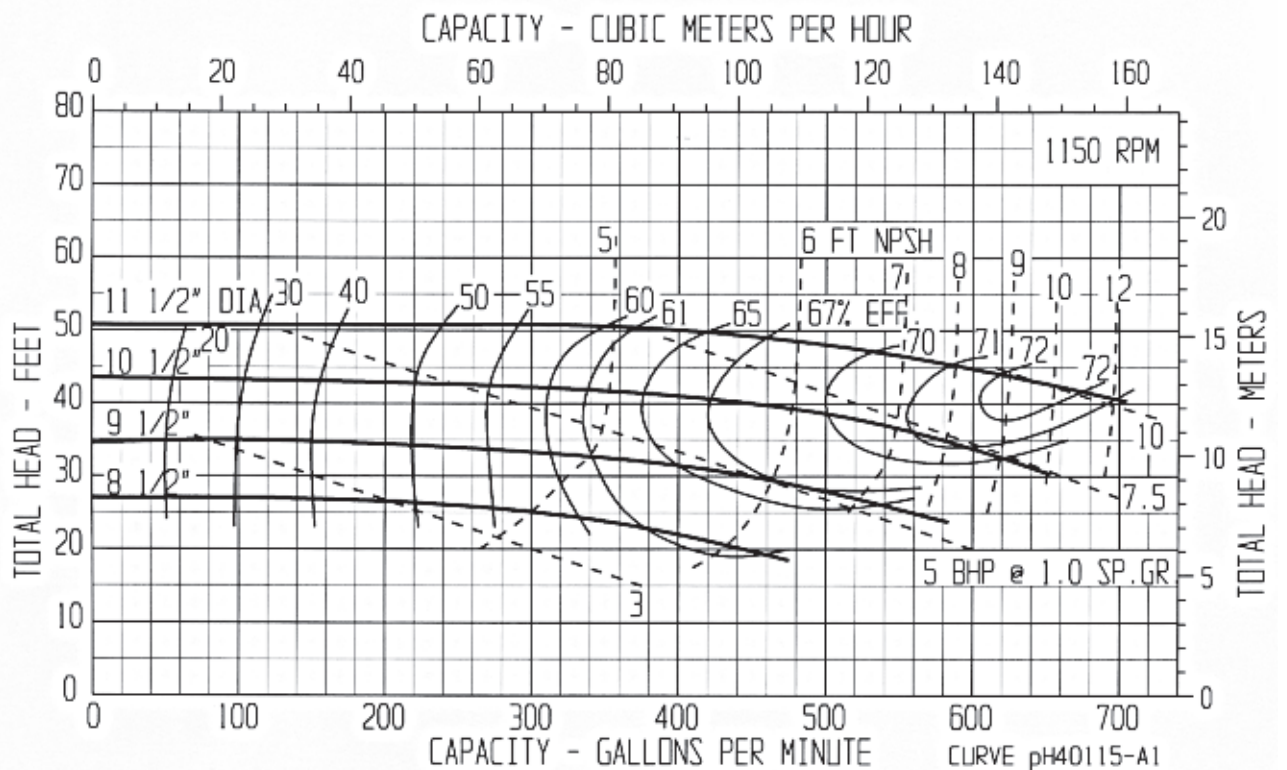
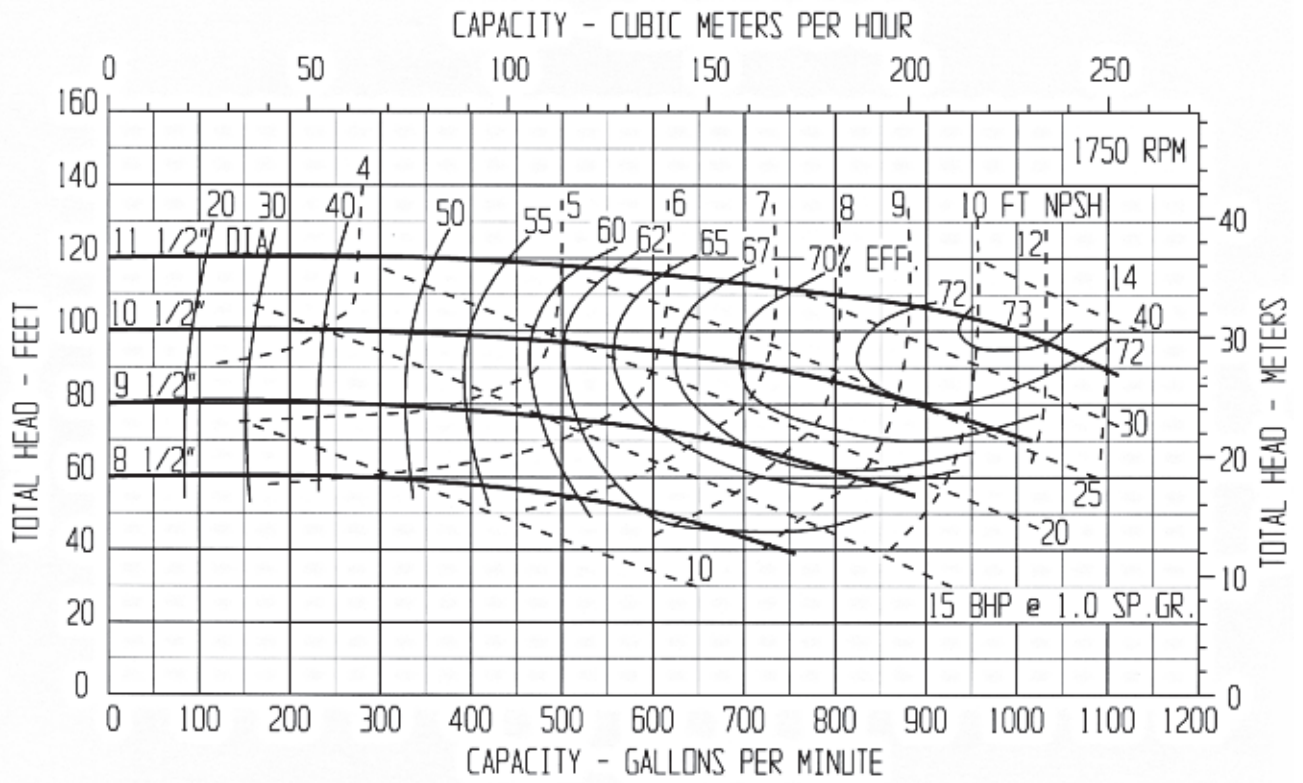

CECO Dean

(317) 293-2930 • E-mail: infofhs@onececo.com

CENTRIFUGAL PUMP PERFORMANCE DATA: CURVE pH40135-B1

PUMP SIZE: 4" X 6" X 13 1/2"

PUMP TYPE: pH2170

MAXIMUM SOLIDS 7/8" DIAMETER

4" DISCHARGE X 6" SUCTION

PUMP PERFORMANCE: This curve, based on extensive tests, defines the average performance of this pump for liquids having a viscosity of 70 SSU or less. Actual performance of individual units may differ slightly from the performance indicated on this curve. Pump applications made from the data contained herein are subject to confirmation and acceptance by our Engineering Department at our Indianapolis Office.

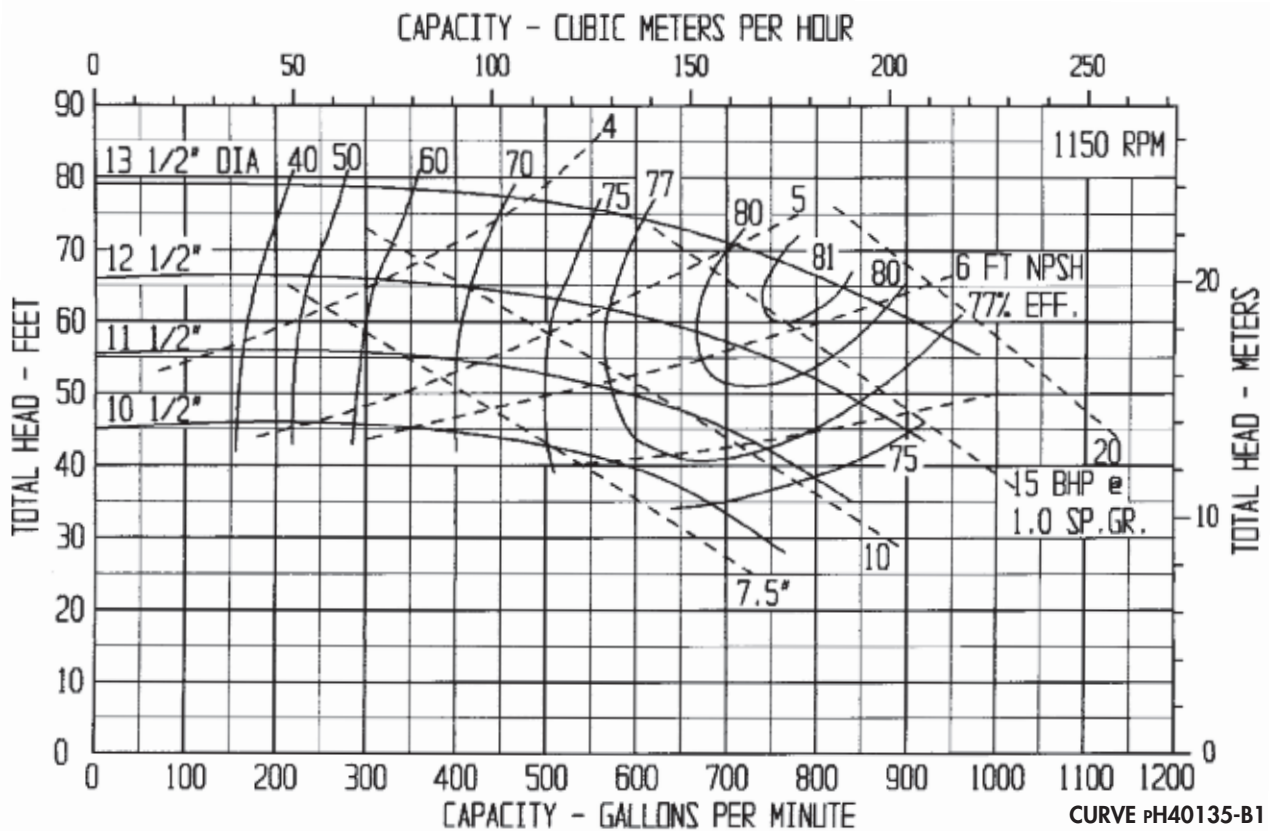
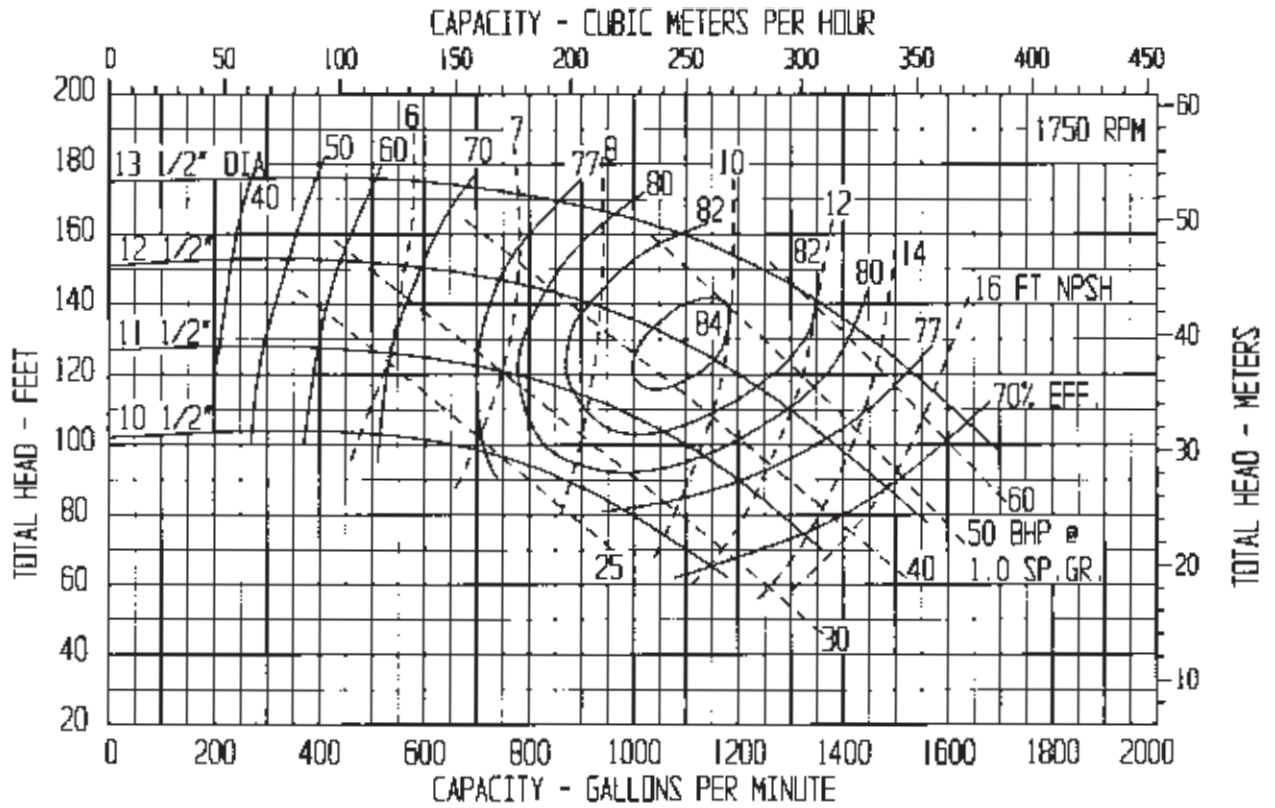

CURVE pH40135-B1

PUMP PERFORMANCE: This curve, based on extensive tests, defines the average performance of this pump for liquids having a viscosity of 70 SSU or less. Actual performance of individual units may differ slightly from the performance indicated on this curve. Pump applications made from the data contained herein are subject to confirmation and acceptance by our Engineering Department at our Indianapolis Office.

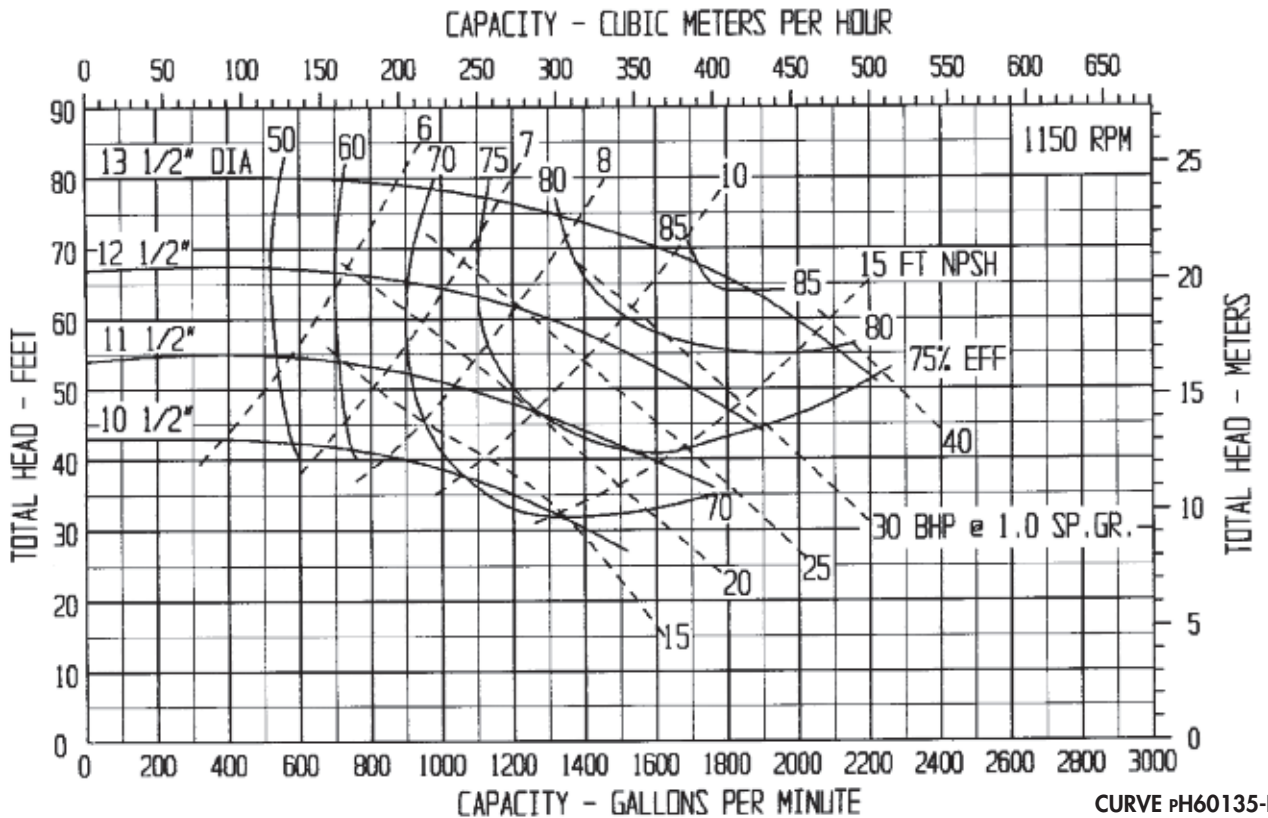
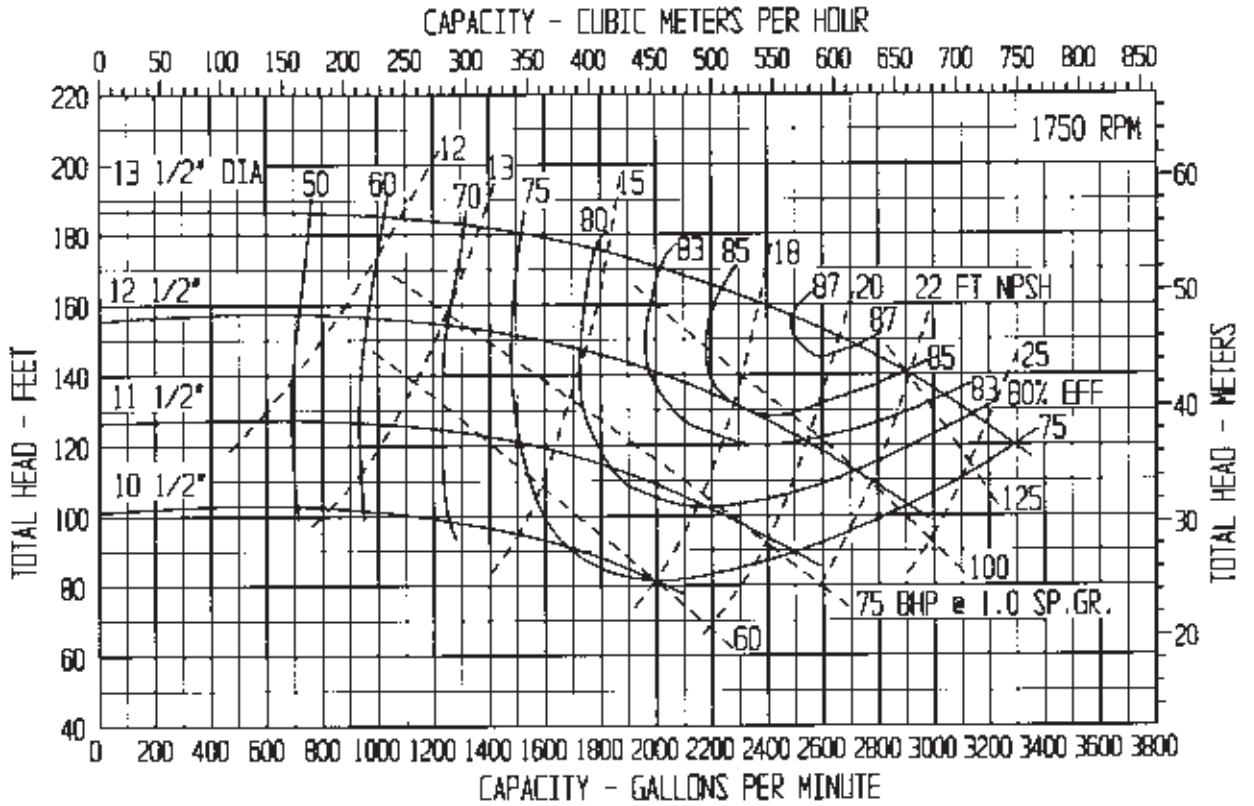

CECO Dean

6040 Guion Road, Indianapolis, IN 46254

Phone 317-293-2930

Email: info@onececo.com

www.cecoenviro.com