

SETHCO® P90 DRUM PUMP

DISASSEMBLY: (Refer to Assembly Drawing for Item Numbers)

1. **Separate motor from pump** by unscrewing collar (1) from motor. Gently pull pump from motor.
2. Remove coupling (4) from pump by simply lifting off.

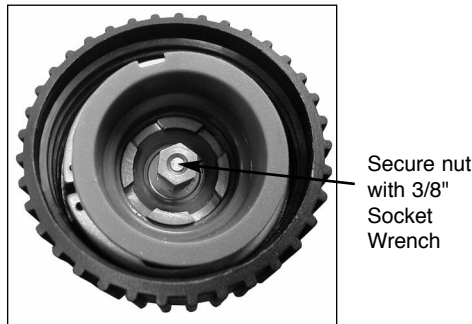

3. **Remove impeller (10)**
 With coupling removed, secure coupling nut with a 3/8" socket wrench.

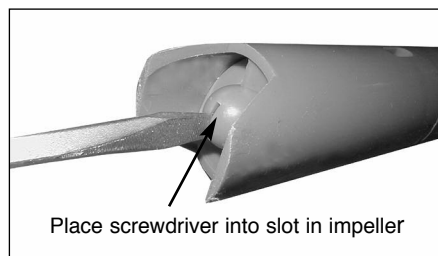

Now turn pump over and place screw driver into screwdriver slot in impeller (10). Unthread impeller (10) by turning it counter clockwise. Hold the 3/8" socket to prevent turning of the coupling nut (5).

4. **Remove bearing cartridge (11) and shaft (7) assembly.** Take coupling (4) and flip it upside down and place it over coupling nut (5) and bearing cartridge (11). The four tabs on the coupling (4) should fit into the corresponding knockout in the bearing cartridge (11). Take a 5/8" socket and place it over the coupling (4) and unthread counter clockwise. Once

bearing cartridge (11) is completely unthreaded, pull assembly out of tube (8) being careful not to bend shaft (7). If vapor seal (3) stays in tube and not on shaft assembly, it is worn and should be replaced.

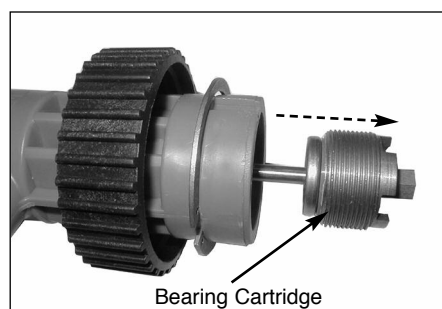
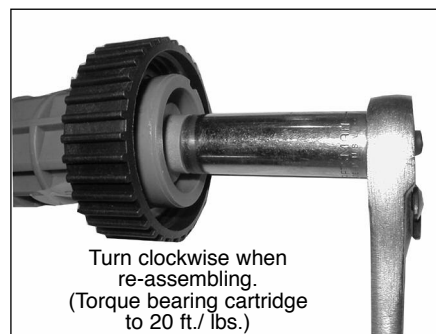
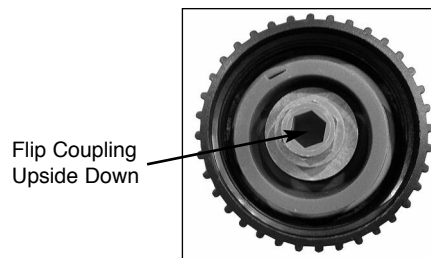

5. Using a small pair of pliers, grip the shaft (7) 2" below the bearing cartridge (11). Using a 3/8" wrench, unthread the coupling nut (5) counter clockwise. Once coupling nut (5) is unthreaded, simply slide the bearing cartridge (11) off the shaft (7). Vapor seal (3) can now slide upward off the shaft (7). Seal (3) should only be removed/installed upward. Check seal (3) for wear and replace if necessary.

6. Remove o-ring (6) from tube (8). Check for damage and replace if necessary.

7. **To remove diffuser (9) from tube (8),** flip the tube (8) upside down so that you can see into the bottom of the pump. Using your coupling (4) again, place the coupling (4) with the four tabs facing into the tube (8) into the bottom of the pump. Using your 5/8" socket, unthread the bearing diffuser (9) by turning counter clockwise. A slight click will be felt as diffusers disengage from lower head. Once unthreaded, pull diffuser (9) out of tube (8). Once removed, the difuser should not be reused.

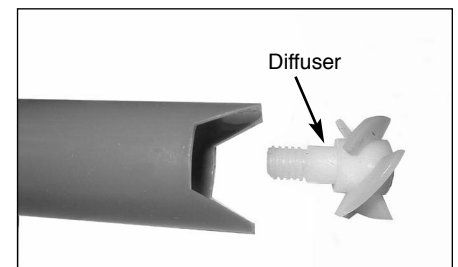

8. Inspect bearing cartridge (11) as follows. Hold both sides of ball bearings and rotate entire assembly slowly by hand. Rotation should be absolutely smooth with no roughness. If continued operation is questionable, replace bearing cartridge (11).

NOTE: These ball bearings are lubricated with special grease. Replace with original factory quality parts only. We strongly recommend that you replace bearing cartridge (11), seal (3) and o-ring (6) together.

ITEM	QTY	DESCRIPTION	MATERIAL	30" PUMP TUBE	40" PUMP TUBE	50" PUMP TUBE	60" PUMP TUBE
				PART #	PART #	PART #	PART #
1	1	COLLAR	POLYPRO	160P644-571	160P644-571	160P644-571	160P644-571
2	1	RETAINING RING (COLLAR)	STEEL	700P5108196-880	700P5108196-880	700P5108196-880	700P5108196-880
3	1	VAPOR SEAL	TEFLON	760P102460-777	760P102460-777	760P102460-777	760P102460-777
4	1	COUPLING	NYLON	170P201975-525	170P201975-525	170P201975-525	170P201975-525
5	1	COUPLING NUT	S.S	170P102453-680	170P102453-680	170P102453-680	170P102453-680
6	1	O-RING	VITON	590P2115-830	590P2115-830	590P2115-830	590P2115-830
7	1	SHAFT	HAST. C	850P9032-340	850P9042-340	850P9052-340	850P9062-340
8A	1	TUBE (Note 1)	POLYPRO	910P9030-580	910P9040-580	910P9050-580	910P9060-580
8B	1	TUBE (Note 1)	PVDF	910P9030-384	910P9040-384	910P9050-384	910P9060-384
9	1	DIFFUSER	TEFZEL	241P102457-769	241P102457-769	241P102457-769	241P102457-769
10A	1	IMPELLER	POLYPRO	430P201979-571	430P201979-571	430P201979-571	430P201979-571
10B	1	IMPELLER	PVDF	430P201979-384	430P201979-384	430P201979-384	430P201979-384
11	1	BEARING CARTRIDGE	POLYPRO/SS	445P90-347	445P90-347	445P90-347	445P90-347
12A	1	STRAINER (Note 2)	POLYPRO	870P90-580	870P90-580	870P90-580	870P90-580
12B	1	STRAINER (Note 2)	PVDF	870P90-384	870P90-384	870P90-384	870P90-384

NOTE 1: Outer shell only, does not include any internal parts

NOTE 2: Optional equipment

ASSEMBLY: (Refer to Assembly Drawing for Item Numbers)

- To assemble diffuser (9) to tube (8), flip tube (8) upside down and thread diffuser (9) into tube (8) using the coupling (4) as in disassembly. Turn until the diffuser vanes "click" into position in the lower head and full resistance is felt.
- Take bearing cartridge (11) and slide it over the shaft (7). Make sure that the four tabs on the bearing cartridge (11) are on top. Now take coupling nut (5) and thread it over the shaft (7). Tighten coupling nut (5) using a small pair of pliers on the shaft, 2" below the bearing cartridge (11) and a 3/8" wrench on the coupling nut (5).
- Slide the vapor seal (3) up the entire length of the shaft (7). Make sure the seal is oriented correctly. Use a drop of Loctite® (medium strength) on the shaft (7) and coupling nut.
- Replace o-ring (6) in the o-ring groove in the top of the pump. Slide bearing cartridge (11)/shaft (7) assembly down the tube (8). Now take the coupling (4), and just as you did when disassembling the pump, flip it over and place the four tabs into the four knockouts in the bearing cartridge (11). Tighten clockwise using a 5/8" socket.
- Leave coupling (4) in bearing cartridge (11) and flip the pump over. Place pump on floor firmly to keep coupling (4) engaged in bearing cartridge (11). Tighten impeller (10) onto the shaft (7) by placing a screwdriver in the slot and turning clockwise.
- Now turn the pump over and flip the coupling (4) over so that the four tabs are facing up. At this point make sure that rotating assembly rotates freely with no binding points rotation. Friction should be uniform through one complete revolution.
- Now install the motor so that cross on motor shaft lines up with the cross in coupling (4). Tighten collar (1) on motor.

ROUTINE BEARING CHECK
Periodically check bearing cartridge (11) for corrosion and wear by loosening collar (1) and removing motor. A good bearing cartridge will spin freely when coupling (4) is turned by hand. Rough bearings or difficult rotating will indicate bearing replacement is required. Another indication of bearing wear is that the top surface of the coupling (4) has dropped 1/16" or more below the top of the pump head. See TD-381-90 Bearing/Coupling page for more information.

SHAFT ORIENTATION

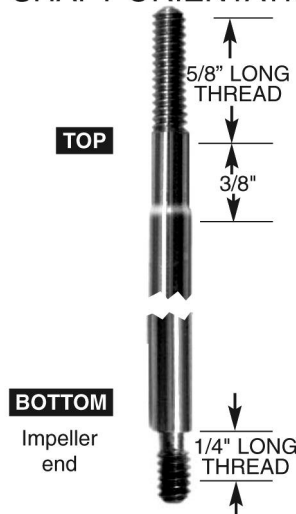

ALWAYS SPECIFY MODEL, SERIAL NUMBER, NAME, PART NUMBER AND DRAWING NUMBER WHEN ORDERING.

ITEM NO.	DESCRIPTION	MATERIAL	QTY.
1	COLLAR	POLYPRO	1
2	RETAINING RING	STEEL	1
3	VAPOR SEAL	TEFLON	1
4	COUPLING	NYLON	1
5	COUPLING NUT	SS	1
6	ORING	VITON	1
7	SHAFT	HAST.C	1
8	OUTER TUBE	POLYPRO OR KYNAR	1
9	DIFFUSER	TEFZEL	1
10	IMPELLER	POLYPRO OR KYNAR	1
11	BEARING CARTRIDGE	POLYPRO/SS	1
12	STRAINER	POLYPRO OR KYNAR	1
13	MOTOR ASSEMBLY	N/A	1

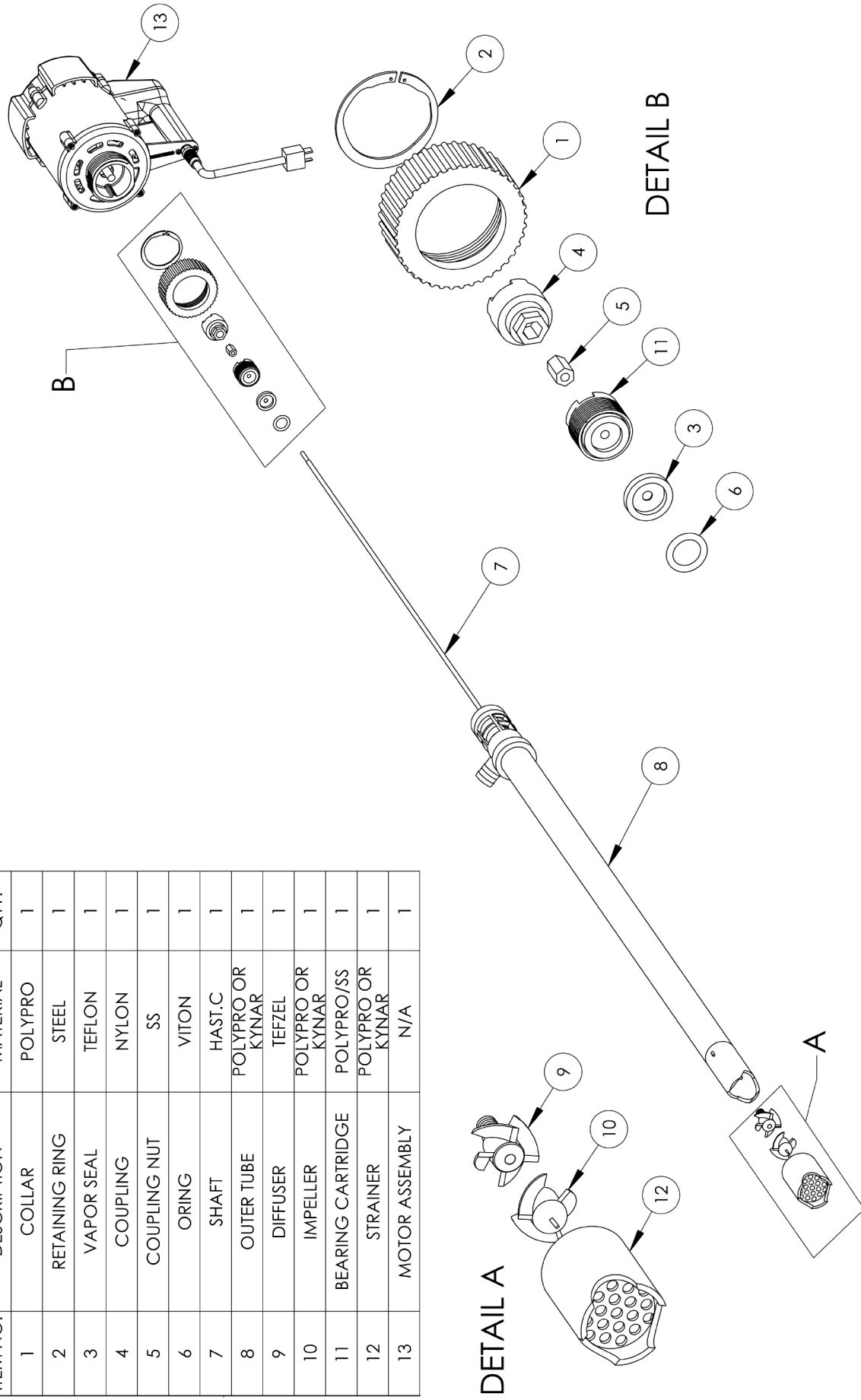

DRAWING NO. 202170-IOM

NEW / GOOD PUMP PROPER POSITION OF COUPLING

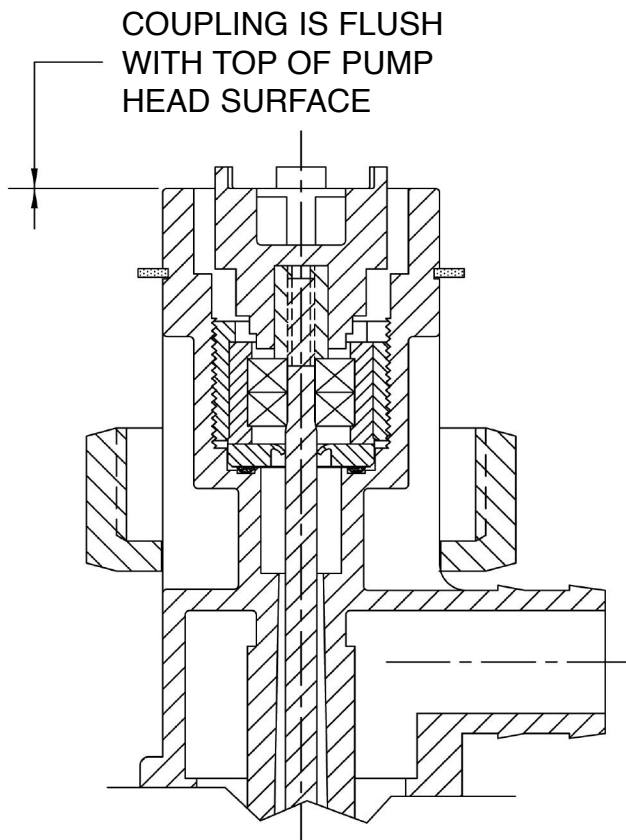

OLD / WORN BEARINGS COUPLING DROPPED, NEEDS BEARINGS

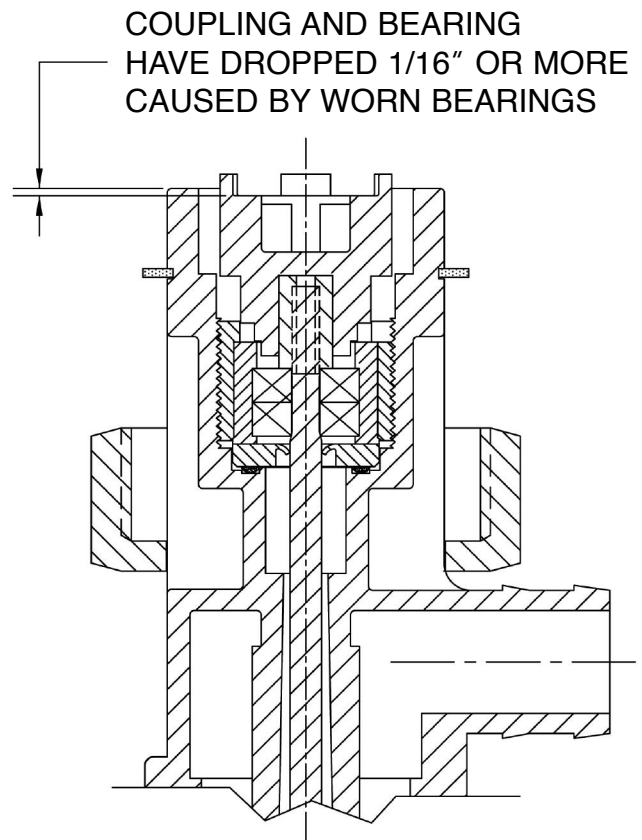

SIGNS OF WORN BEARINGS

- Coupling wears out, needs replacement
- Motor speed slows down
- Motor speed varies while pumping
- Smell of plastic burning
- Flow from pump is degraded

TROUBLESHOOTING

- Periodically check for free rotation of coupling by hand. Some resistance is normal, but roughness or difficulty turning indicates bearing replacement is needed.
- Compare height of top of coupling with top of pump head. They should be nearly flush. If they have dropped 1/16" or more, replace bearings. Inspect and replace vapor seal and coupling if necessary.

MOTOR OPTIONS

115V MOTOR 381-U1

230V MOTOR 381-U2

— CAUTION —

**WEAR PROTECTIVE CLOTHING AND EQUIPMENT
WHEN OPERATING OR SERVICING**

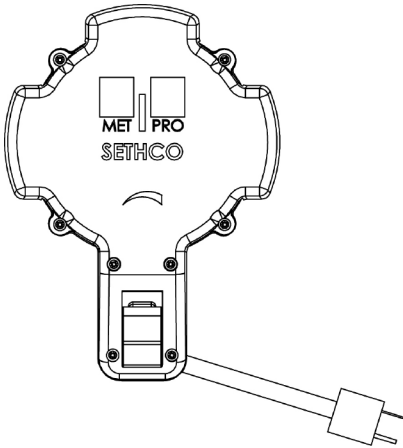

Trouble shooting:

- 1) If the motor stops, reset switch/circuit breaker by turning the motor off
- 2) If the motor does not restart, disconnect from power source
- 3) Separate motor from pump
- 4) Spin shaft by hand to see if it will rotate
- 5) If shaft rotates freely, reconnect to power source and jog
- 6) If motor still does not work, consult factory

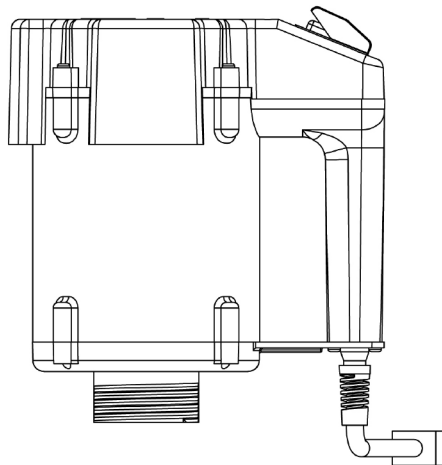
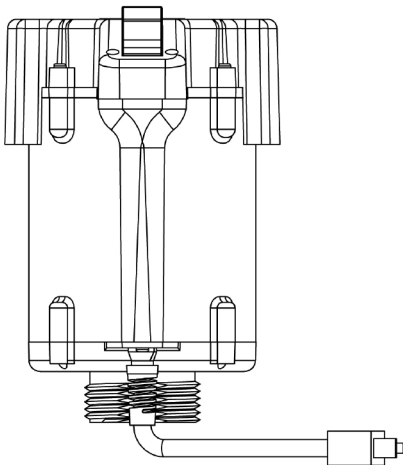

WARNING!

**DO NOT USE WHEN
COMBUSTIBLE OR
FLAMMABLE
CONDITIONS EXIST.
MOTOR CAN SPARK!
EXPLOSION OR
INJURY OR DEATH
CAN OCCUR.**

AIR MOTOR 381-A

ITEM	NAME	REQ'D	PART NUMBER
21	Air Motor	1	576P500182-509
22	Adapter	1	010P60-550
23	Valve (Brass)	1	940P22-080
24	Coupling Assembly	1	851P102523-720
25	Set Screw	2	800P102402-680
26	Set Screw	2	800P022005-720

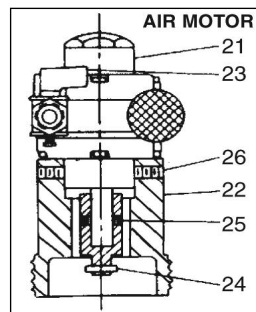

P90 DRUM PUMPS - SAFETY RULES

CAUTION: Read rules for safe operation and instructions carefully

1. **KNOW YOUR UNIT**—Read owners manual carefully. Learn its applications, limitations, capabilities and proper use.
2. **HAZARDOUS LOCATIONS**—Use hazardous duty motor in locations where fire or explosion hazards may exist due to flammable gases or vapors. Use air motor in a dust environment. Use stainless steel pump for flammable liquids.
3. **KEEP WORK AREA CLEAN**—Cluttered areas and benches invite accidents.
4. **AVOID DANGEROUS ENVIRONMENT**—As with any electric power tool, don't expose the unit to rain.
5. **KEEP BYSTANDERS AWAY**—All visitors and unauthorized persons should be kept a safe distance from work areas.
6. **STORE PROPERLY**—As with any power tool, when not in use, unit should be cleaned and stored in a dry place away from unauthorized personnel.
7. **DON'T FORCE TOOL**—Do not use pump to break ice in drums or break up sludge masses. Rapid wear and/or damage will occur when pumping abrasives or thick materials.
8. **WEAR PROPER APPAREL**—No loose clothing or jewelry to get caught on hoses or cords. Rubber gloves, aprons and footwear are recommended.
9. **USE SAFETY GLASSES**—The operation of any power tool can result in foreign objects (splashing) being thrown into the eyes, which can result in severe eye damage. Always wear safety glasses with eye shields before commencing power tool operation. We recommend Wide Vision Safety Mask for use over spectacles, or safety glasses.
10. **DON'T ABUSE CORD**—Never carry tool by cord or yank it to disconnect from receptacle. Keep cord from heat and sharp edges.
11. **SECURE PUMP AND HOSE**—When not pumping from a drum, secure pump to prevent accidental immersion into tanks. Secure discharge end of hose to prevent "whipping" of hose. Secure hose clamp tight.
12. **DO NOT IMMERSE**—pump into fluid above pump discharge. Do not immerse motor in any fluid.
13. **DON'T OVERREACH**—Keep proper footing and balance at all times.
14. **MAINTAIN EQUIPMENT** with care—Keep pump clean for best performance. Follow maintenance instructions.
15. **DISCONNECT MOTOR**—when not in use and before servicing, remove plug from power supply.
16. **AVOID ACCIDENTAL STARTING**—Don't carry plugged-in tool with finger on switch. Be sure switch is off when plugging in.
17. **KEEP HANDS AND FINGERS AWAY FROM IMPELLER.**
18. **KEEP FACE AWAY**—Don't look into hose, pump discharge or suction.
19. **REVIEW MATERIAL SAFETY DATE SHEET OF THE PRODUCT TO BE PUMPED.**



INTRODUCTION

DOUBLE INSULATION is a concept in safety, in electric power tools, which eliminates the need for the usual three wire grounded power cord and grounded supply system. Wherever there is electric current in the tool there are two complete sets of insulation to protect the user. All exposed metal parts are isolated from the internal metal motor components with protecting insulation.

HAZARDOUS DUTY MOTOR — When service is required, return to factory. NOTE: This motor is equipped with a thermal overload sensor. When activated the pump will stop and re-start automatically when the motor cools.

SWITCH

The standard 115V & 230V electric P90 motor is equipped with a rocker switch located in the upper part of the handle. Press the upper part of the rocker to start and the opposite half to stop. The switch has a built in circuit breaker which will trip the switch in the event of an overload. Be sure switch is in the "off" position before connecting to power supply.

SWITCH

The hazardous duty motor is equipped with a rotary switch. Make sure the switch is in the "off" position before connecting to power supply.

OPERATION

1. Align coupling splines and motor spline.
2. Align motor key and pump head.
3. Insert pump head into motor and secure with collar (1).
4. Slip hose clamp over hose end.
5. Slip hose onto pump discharge. Push hose onto full length of discharge nipple. (1-1/8 inches).
6. Align hose clamp between discharge nipple "barbs".
7. Tighten hose clamp.

START-UP (CAUTION — OBSERVE SAFETY RULES)

1. Insert pump into drum.
2. Control or secure discharge hose.
3. Plug in motor.
4. Switch unit on.

STOPPING

1. Switch unit off.
2. Unplug motor.
3. Lift pump from fluid slowly; allowing pump to drain.

STORAGE

1. Run pump in a rinsing solution for 30 seconds with discharge hose open and 30 seconds with discharge hose closed.
2. Allow pump to drain.
3. Store upright in a secure area to prevent unauthorized use.

MAINTENANCE

When servicing, replace with original factory quality parts only. Only the parts shown in the materials list are intended to be replaced by the customer.

TROUBLE SHOOTING

Problem: Pump doesn't pump

Probable Cause	Remedy
1. Motor not turning	1. Check electric outlet and plug 2. Check rocker switch 3. Unplug motor and remove pump, keeping fingers clear of spline. Plug in and test motor.
2. Pump coupling sheared	1. Replace
3. Solution solidified in pump	1. Flush
4. Impeller damaged	1. Replace
5. Pump bearings "frozen"	1. Replace
6. Debris in suction	1. Unplug pump motor and clear
7. Hose crimped	1. Straighten
8. Less than 2" of liquid in drum	1. Tilt drum

Problem: Pump capacity reduced

1. Worn impeller and/or suction intake	1. Replace
2. Low voltage	1. Check outlet
3. Thick fluids	1. Consult factory
4. Hose crimped	1. Straighten
5. Pump bearings worn	1. Replace
6. Suction partially clogged	1. Unplug motor and clean
7. Discharge line restricted	1. Unplug motor and clear

NOTES

CECO Sethco

700 Emlen Way • Telford, PA 18969
Phone: 215.723.8155
Email: infoths@onececo.com
www.cecoenviro.com