

CECO Sethco

CECO Sethco: 700 Emlen Way, Telford, PA 18969
Tel: 215-723-8155 • Website: www.cecoenviro.com • Email: gdrtq@onececo.com

PD-381-02B
MODEL P90S
STAINLESS STEEL 316
DRUM PUMP

PARTS LIST

February 1, 2000

Supersedes PD-381-02A, dated 6-1-97

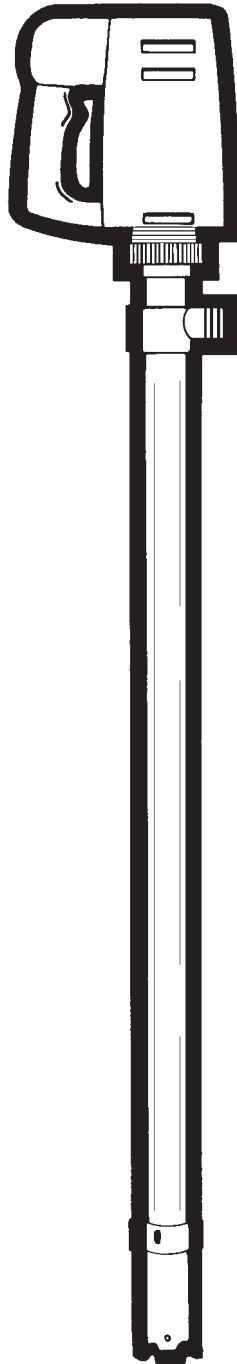

P
90
DRUM
PUMP

Features

115V AND 230V MOTOR
SEALLESS
CONTINUOUS DUTY SERVICE
SELF PRIMING
POWERFUL DOUBLE
INSULATED 1150 WATT MOTOR
STAINLESS STEEL
CONSTRUCTION
MADE IN U.S.A.

ALWAYS SPECIFY MODEL, SERIAL NUMBER, NAME PART NUMBER AND THIS DRAWING NUMBER WHEN ORDERING.

Congratulations:

You have just purchased a quality industrial drum pump, manufactured to exacting standards. To provide for the safe operation and prolong the life of your purchase, please review the operating instructions and become familiar with the P90 drum pump. Thank you for choosing a Sethco product. We look forward to serving your future requirements

MOTORS

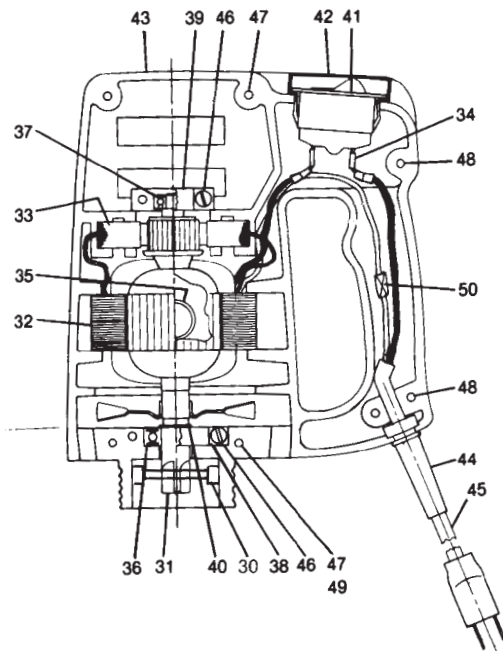

115V and 230V MOTORS

ITEM	NAME	REQ'D	PART NUMBER
31	Armature - 115V (Note 4)	1	020P990346-195
31A	Armature - 230V (Note 5)	1	020P990971-195
32	Field - 115V (Note 4)	1	302P990347-195
32A	Field - 230V (Note 5)	1	302P99068-195
33	Brush & Holder Assy. (Note 4 & 5)	2	032P80-195
34	Spade Connection	1	171P12646-195
35	O-Ring	1	590P2210-341
36	Bearing (Note 4 & 5)	1	080P622149-720
37	Bearing (Notes 4 & 5)	1	080P621221-720
38	Clamp	1	130P80716-720
39	Clamp	1	130P8004-720
40	Retaining Ring (Notes 4 & 5)	1	700P622167-720
41	Switch-115V	1	871P808-195
41A	Switch - 230V	1	871P804#1-195
42	Cover	1	140P101710-195
43	Motor Housing	1	450P80-593
44	Bend Relief	1	700P182-195
45	Cord - 115V	1	132P18216-195
45A	Cord-230V (Note 8)	1	132P18217-195
46	Screw	4	790P101604-720
47	Pan Head Screw	4	790P10102-680
48	Pan Head Screw	3	790P101006-680
50	Connector	1	171P311-195
51	Armature - Field Set, 115V (Note 1)	1	578P80-195
52	Armature - Field Set, 230V (Note 2)	1	578P801-195
53	Motor Assy. - 115V (Note 6)	1	381-B
54	Motor Assy. - 230V (Note 7)	1	381-C

NOTES

- Includes 1 each of items 31, 32, 36, 37, 40 and 2 each of item 33.
- Includes 1 each of items 31A, 32A, 36, 37, 40 and 2 each of item 33.
- Includes items 36, 37, 40.
- Included with item 51.
- Included with item 52.
- Includes items 31-50.
- Includes items 31A-50.
- Does not include plug.

MAINTENANCE DISASSEMBLY

- Isolate pump electrically.
- Separate motor from pump.



—CAUTION—
**WEAR PROTECTIVE CLOTHING AND EQUIPMENT
ALWAYS DISCONNECT FROM POWER SOURCE
BEFORE SERVICING.**

- Relocate motor to repair area.
- Remove screws (47, 48).
- Remove upper half of motor housing.
- Remove screws (46) and clamps (38, 39).
- Remove brush assemblies (33).
- Remove field (32) and armature (31).

INSPECTION

- Check brushes (33) for rough wear or cracks, and free travel.
- Check all connections.
- Check all wires for cuts or nicks.
- Check bearings (36, 37) by rotating with fingers. If there is a bumpy or sandy feeling, replace.
- Check armature (31) If commutator's surfaces are rough or winding wire burned, replace armature.
- Check field (32) If winding is burned, replace.
- Check switch (41) If rocker does not stay in ON or OFF position replace switch.

ASSEMBLY

- Slide armature (31) into field (32) with white wire facing commutator.
- With white wire facing up, place armature (31) and field (32) into motor housing (43) so that bearings (36,37) and field (32) are properly seated.
- Install clamps (38, 39) using screws (46).
- Check armature (31) for free rotation.
- Install brush assemblies (33).
- Install switch (41) with yellow sticker facing up.
- Press black and white wires (black wire leading to the switch) into the groove in motor housing, making sure no wire can come in contact with armature.
- Place O-ring (35) in upper half of motor housing.
- Place two halves of motor housing together, properly aligned.
- Secure motor housings with screws (47, 48).
- Snap in switch (41) with cover (42).

TESTING

Jog motor and listen for smoothness of running.

ITEM	QTY	DESCRIPTION	MATERIAL	381-09040-ST
1	1	Pump Tube Assembly	SS-316	910P9 040-670
2	1	Shaft	Carp-20	850P800241-130
3	1	Bearing (Spiral)	Teflon	080P102432-770
4	1	Bearing Retainer	Teflon	700P8004-770
5	1	Impeller	PVDF	430P97-384
6	1	Coupling Spider	Nylon	170P801-585
7	1	Coupling	Nylon	170P8051618-525
8	1	Collar	Poly-pro	160P644-571
9	1	Retaining Ring	Steel	700P5108196-880
10	2	Retaining Ring	Steel	700P510039-720
11	2	Bearings	33-304	080P10268-680
12	1	Retaining Ring	Steel	700P3000102-720
13	1	Seal Vapor	Teflon	760P102017-770
14	1	Coupling Shaft	SS-316	850P10201-670
15	1	Retaining Ring	SS-316	700P80-670
16	1	Screen	SS-316	870P102015-670
17*	1	Bearing Housing	SS-316	440P201373-670
18*	1	Inner Tube Assembly	SS-316	981P8041-670
19*	1	Teflon Spacer	Teflon	770P80-770
20 (not shown)	1	Coupling/shaft/bearing/seal assembly	various	853P201427-671

*ITEMS (18) and (19) are part of item 1 (pump tube assembly) but can be ordered separately as spare parts.

†Includes item 10, 11, 13, and 14 fully assembled.

DISASSEMBLY:

1. Separate motor from pump by unscrewing collar, (8) from motor. Gently pull pump from motor.
2. Remove retaining ring (15) from lower head. Remove screw (16) and set aside
3. Place a wide screwdriver in coupling spider (6) to keep it from turning and unscrew impeller (5) (left hand thread) using a screwdriver between two of the vanes of the impeller.
4. Remove coupling spider (6) by lifting out.
5. Hold coupling (7) to prevent rotation Insert a small screwdriver in the slot of coupling shaft (14) and unscrew coupling
6. Unscrew ball bearing housing (17) from pump and remove complete assembly, including shaft, from pump.
7. Place a small screwdriver in slot of coupling shaft (14) and, using a small pair of pliers, grip shaft (2) just below the ball bearing housing (17). Unscrew pump shaft.
8. Insert the head of a small common nail into the bearing retainer (4). Hook the back end of bearing retainer and pull it out along with the bearing (3)
9. Before dismantling ball bearing housing (17) inspect ball bearings (11) as follows: Grasp coupling shaft (14) and rotate ball bearing housing (17) by hand slowly. Rotation should be absolutely smooth with no roughness. If continued operation is questionable, replace ball bearings (11).

NOTE: These ball bearings are lubricated with special grease. Replace with original factory quality parts only. We strongly recommend that you replace ball bearings and seal together as a complete assembly with coupling shaft. See item 14. Otherwise see ball bearing and seal replacement instructions below.

BALL BEARING and SEAL REPLACEMENT:

1. Remove retaining ring (10) from both ends of ball bearing housing (17).
2. Remove bearing housing components by pushing out coupling shaft (14) and ball bearings (11) simultaneously
3. While supporting a ball bearing (11) and seal (13), remove from coupling shaft (14)
4. Repeat step 3 for other ball bearing (11).
5. Replace ball bearings by pressing on to shaft in the same manner in which they were first removed .
6. Once ball bearing (11) and seal (13) are located on coupling shaft (14), press entire assembly into bearing housing (17) and install retaining rings (10).

REASSEMBLY:

- (1) To assemble bearing (3) to bearing retainer (4), insert bearing into 3/8 inch diameter end of bearing retainer and pull 1" of bearing through slot Wrap 1" end of bearing (3) onto bearing retainer (4) for 3/4 of one turn. Bearing must be wrapped on the mid section of bearing retainer so as not to interfere with shoulders at each end.
2. Install bearing (3) and bearing retainer (4) assembly into pump tube (1)
3. Screw shaft (2) into coupling shaft (14).
4. Carefully guide the shaft (2) into the center of pump tube (1) without force. Then secure ball bearing housing (17) by screwing into pump tube
5. Install coupling (7) onto coupling shaft (14).
6. Insert coupling spider (6) into coupling (7).
7. While holding coupling spider (6), install impeller (5) onto shaft (2) (left hand thread) tighten impeller using a screwdriver between two vanes of the impeller.
8. Install screen (16) and retaining ring (15) into pump tube (1) tighten impeller using a screwdriver between 2 vanes of the impeller.

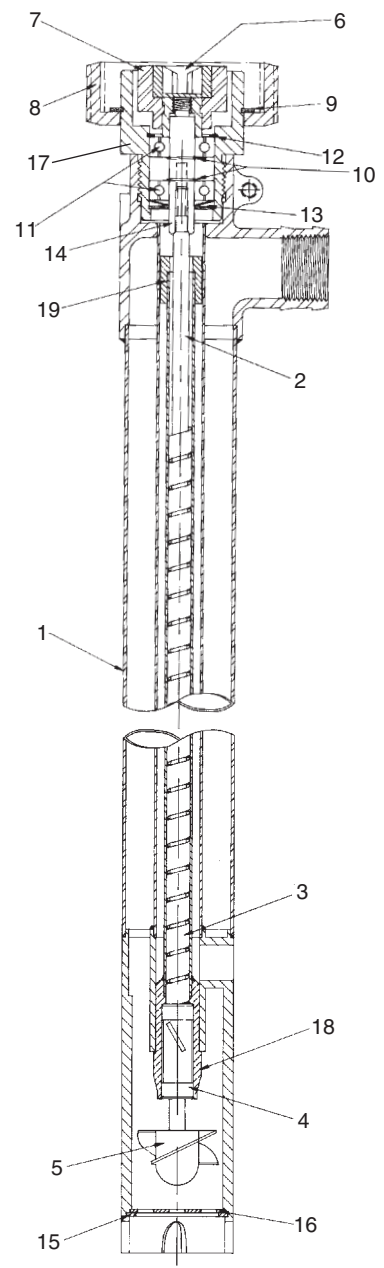

STAINLESS STEEL P90 DRUM PUMPS - SAFETY RULES

CAUTION: Read rules for safe operation and instructions carefully

- KNOW YOUR UNIT**—Read owners manual carefully. Learn its applications, limitations, capabilities and proper use.
- HAZARDOUS LOCATIONS**—Use hazardous duty motor in locations where fire or explosion hazards may exist due to flammable gases or vapors. Use air motor in a dust environment. Use stainless steel pump for flammable liquids.
- KEEP WORK AREA CLEAN**—Cluttered areas and benches invite accidents.
- AVOID DANGEROUS ENVIRONMENT**—As with any electric power tool, don't expose the unit to rain.
- KEEP BYSTANDERS AWAY**—All visitors and unauthorized persons should be kept a safe distance from work areas.
- STORE PROPERLY**—As with any power tool, when not in use, unit should be cleaned and stored in a dry place away from unauthorized personnel.
- DON'T FORCE TOOL**—Do not use pump to break ice in drums or break up sludge masses. Rapid wear and/or damage will occur when pumping abrasives or thick materials.
- WEAR PROPER APPAREL**—No loose clothing or jewelry to get caught on hoses or cords. Rubber gloves, aprons and footwear are recommended.
- USE SAFETY GLASSES**— The operation of any power tool can result in foreign objects (splashing) being thrown into the eyes, which can result in severe eye damage. Always wear safety glasses with eye shields before commencing power tool operation. We recommend Wide Vision Safety Mask for use over spectacles, or safety glasses.
- DON'T ABUSE CORD**—Never carry tool by cord or yank it to disconnect from receptacle. Keep cord from heat and sharp edges.
- SECURE PUMP AND HOSE**—When not pumping from a drum, secure pump to prevent accidental immersion into tanks. Secure discharge end of hose to prevent "whipping" of hose. Secure hose clamp tight.
- DO NOT IMMERGE**—pump into fluid above pump discharge. Do not immerse motor in any fluid.
- DON'T OVERREACH**—Keep proper footing and balance at all times.
- MAINTAIN EQUIPMENT** with care — Keep pump clean for best performance. Follow maintenance instructions.
- DISCONNECT MOTOR**—when not in use and before servicing, remove plug from power supply.
- AVOID ACCIDENTAL STARTING**—Don't carry plugged-in tool with finger on switch. Be sure switch is off when plugging in.
- KEEP HANDS AND FINGERS FROM IMPELLER.**
- KEEP FACE AWAY**—Don't look into hose, pump discharge or suction.
- REVIEW MATERIAL SAFETY DATE SHEET OF THE PRODUCT TO BE PUMPED.**



INTRODUCTION

DOUBLE INSULATION is a concept in safety, in electric power tools, which eliminates the need for the usual three wire grounded power cord and grounded supply system. Wherever there is electric current in the tool there are two complete sets of insulation to protect the user. All exposed metal parts are isolated from the internal metal motor components with protecting insulation.

IMPORTANT — Servicing of a motor with double insulation requires extreme care and knowledge of the system and should be performed only by a qualified service technician. For service, we recommend returning your motor to Sethco.

HAZARDOUS DUTY MOTOR — When service is required, return to factory. NOTE: This motor is equipped with a thermal overload sensor. When activated the pump will stop and re-start automatically when the motor cools.

SWITCH

The standard 115V & 230V electric P90 motor is equipped with a rocker switch located in the upper part of the handle. Press the upper part of the rocker to start and the opposite half to stop. The switch has a built in circuit breaker which will trip the switch in the event of an overload. Be sure switch is in the "off" position before connecting to power supply.

SWITCH

The hazardous duty motor is equipped with a rotary switch. Make sure the switch is in the "off" position before connecting to power supply.

OPERATION

- Align coupling splines and motor spline.
- Align motor key and pump head.
- Insert pump head into motor and secure with collar (1).
- Slip hose clamp over hose end.
- Slip hose onto pump discharge. Push hose onto full length of discharge nipple. (1-1/8 inches).
- Align hose clamp between discharge nipple "barbs".
- Tighten hose clamp.

START-UP (CAUTION — OBSERVE SAFETY RULES)

- Insert pump into drum.
- Control or secure discharge hose.
- Plug in motor.
- Switch unit on.

STOPPING

- Switch unit off.
- Unplug motor.
- Lift pump from fluid slowly; allowing pump to drain.

STORAGE

- Run pump in a rinsing solution for 30 seconds with discharge hose open and 30 seconds with discharge hose closed.
- Allow pump to drain.
- Store in a secure area to prevent unauthorized use.

MAINTENANCE

When servicing, replace with original factory quality parts only. Only the parts shown in the materials list are intended to be replaced by the customer. The standard 115V & 230V motor is equipped with a "DOUBLE INSULATION" system and should be serviced only by a qualified service technician.

TROUBLE SHOOTING

Problem: Pump doesn't pump

Probable Cause	Remedy
1. Motor not turning	1. Check electric outlet & plug 2. Check rocker switch 3. Unplug motor and remove pump, keeping fingers clear of spine. Plug in and test motor. 4. Return to factory
2. Motor bearing "frozen"	1. Return to factory
3. Motor brushes worn	1. Return to factory
4. Pump coupling sheared	1. Replace
5. Solution solidified in pump	1. Flush
6. Impeller damaged	1. Replace
7. Pump bearings "frozen"	1. Replace
8. Debris in suction	1. Unplug pump motor & clear
9. Hose crimped	1. Straighten
10. Less than 2" of liquid in drum	1. Tilt drum

Problem: Pump capacity reduced

1. Worn impeller and/or suction intake	1. Replace
2. Low voltage	1. Check outlet
3. Thick fluids	1. Consult factory
4. Hose crimped	1. Straighten
5. Pump bearings worn	1. Replace
6. Motor bearing worn	1. Return to factory
7. Suction partially clogged	1. Unplug motor and clean
8. Discharge line restricted	1. Unplug motor and clear

CECO Sethco